

SAUF INDICATION CONTRAIRE: LES COTES SONT EN MILLIMETRES ETAT DE SURFACE: TOLERANCES: LINEAIRES: ANGULAIRES:			FINITION:		CASSER LES ANGLES VIFS		NE PAS CHANGER L'ECHELLE		REVISION	
									TITRE:	
									No. DE PLAN	
									carrure mise en plan	
									Echelle: 2:1	
									FEUILLE 1 SUR 1	

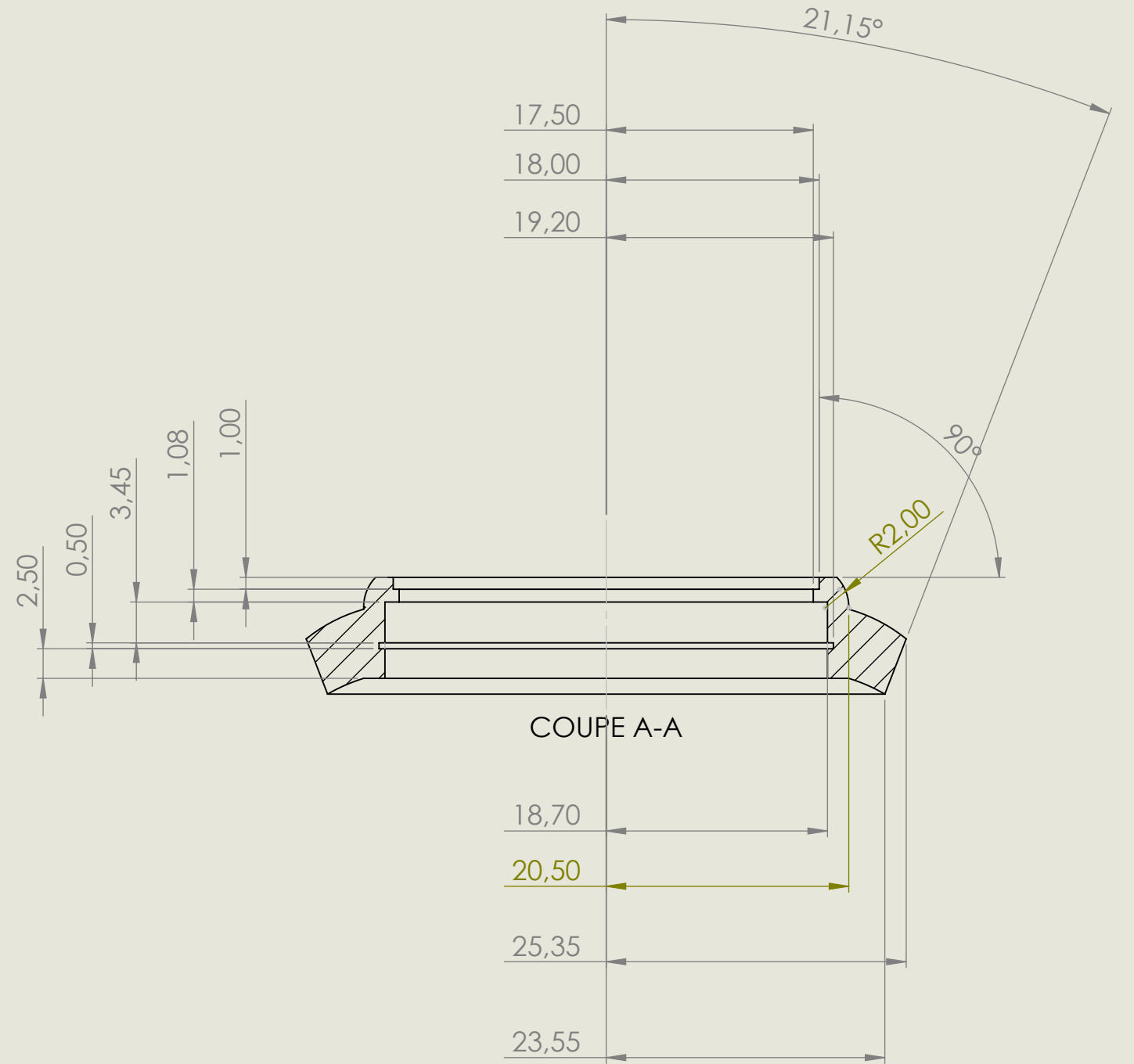

SAUF INDICATION CONTRAIRE: LES COTES SONT EN MILLIMETRES ETAT DE SURFACE: TOLERANCES: LINEAIRES: ANGULAIRES:		FINITION:		CASSER LES ANGLES VIFS		NE PAS CHANGER L'ECHELLE		REVISION	
AUTEUR		SIGNATURE		DATE		TITRE:			
VERIF.									
APPR.									
FAB.									
QUAL.				MATERIAU:		No. DE PLAN			
						carrure mise en plan		A3	
				MASSE:		ECHELLE:2:1		FEUILLE 1 SUR 1	

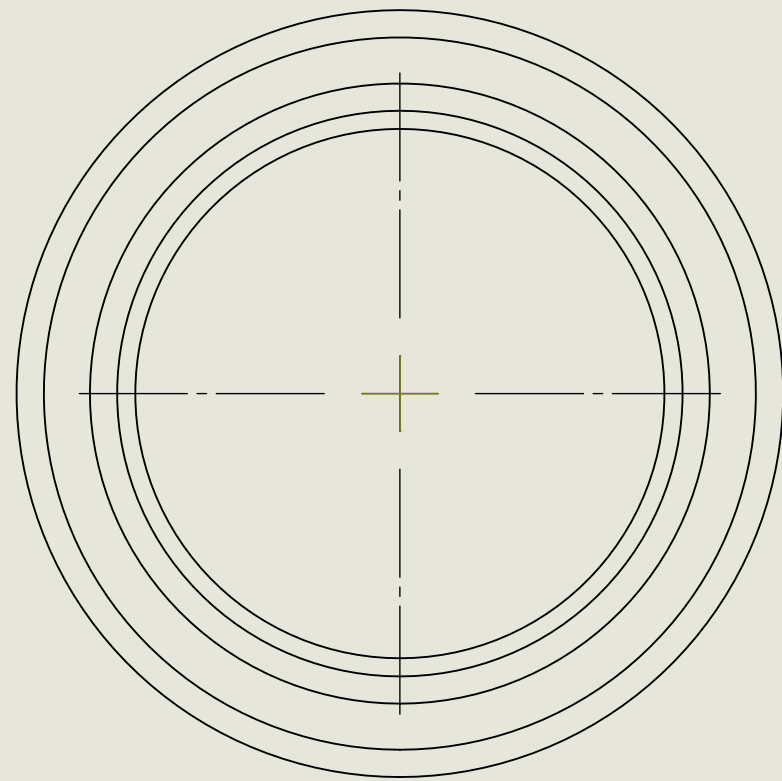
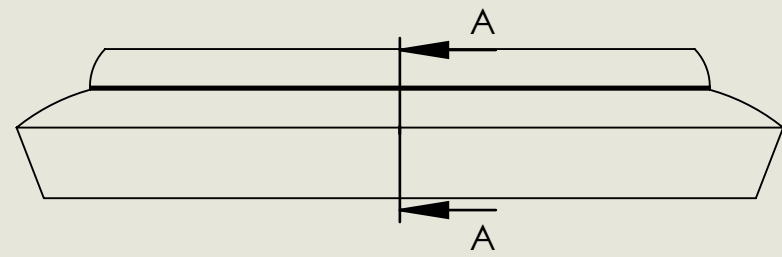
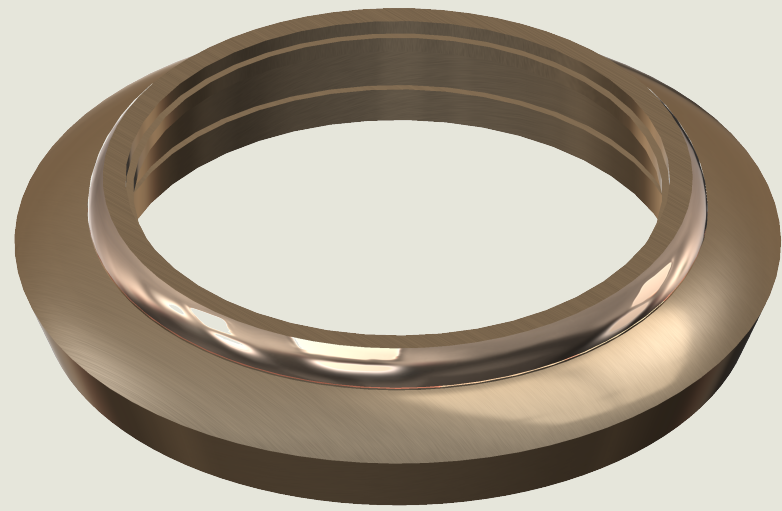
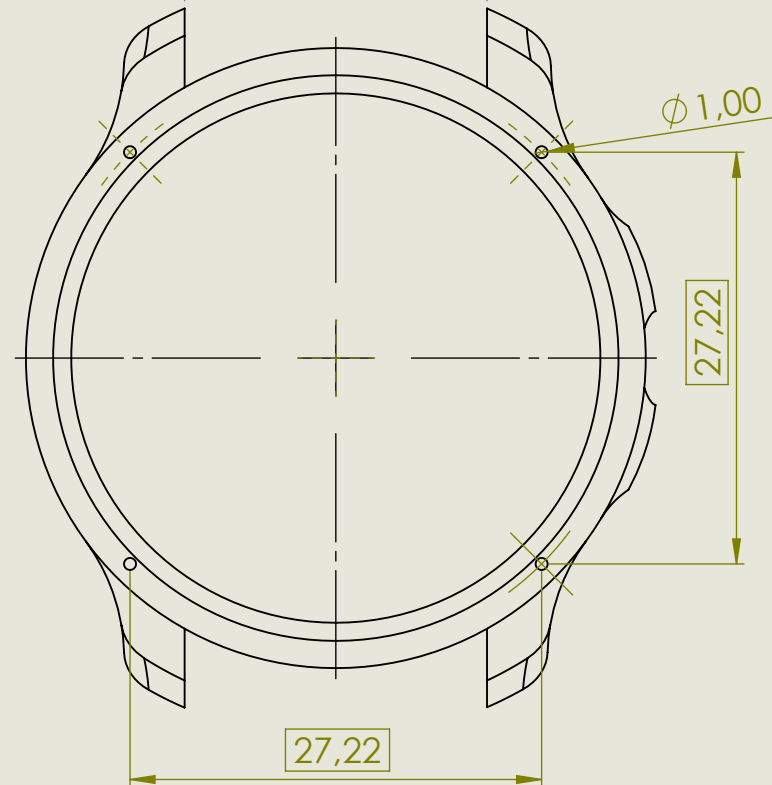
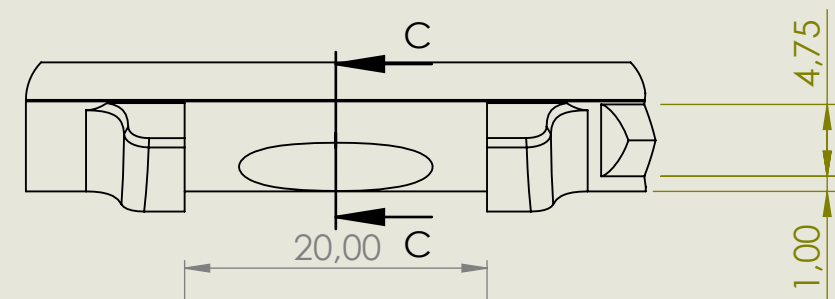
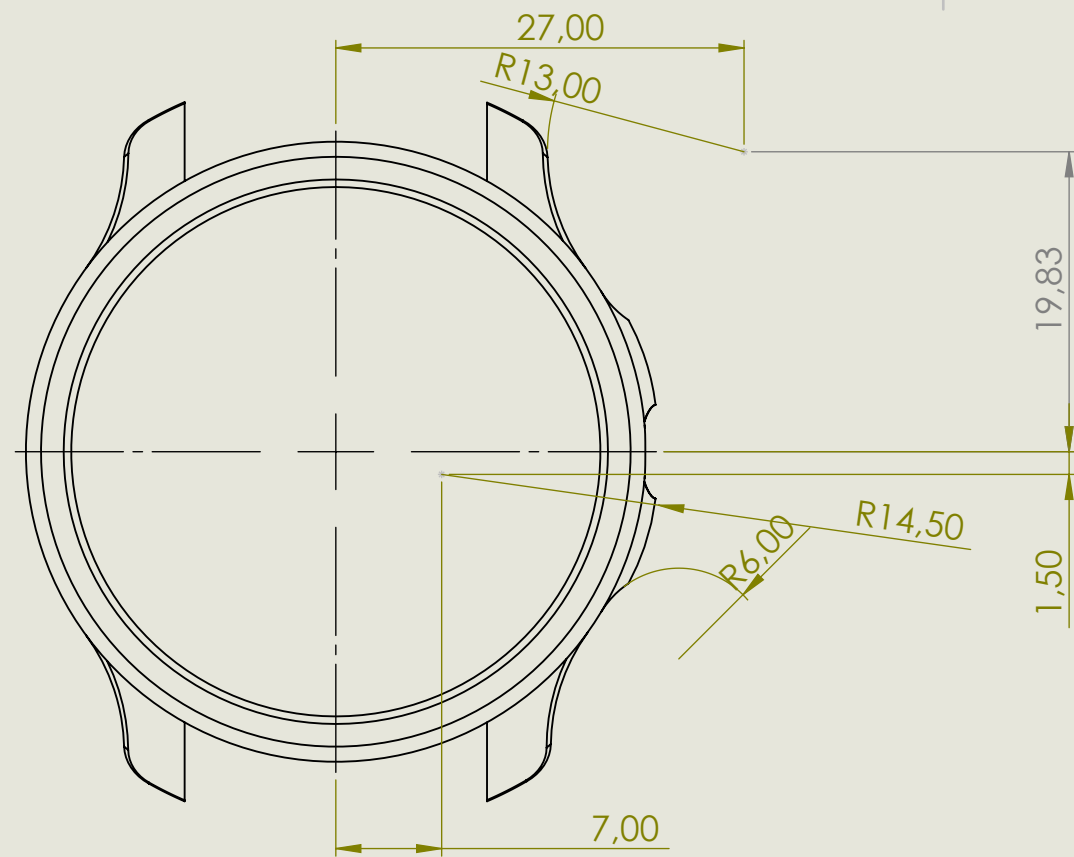

Ø 1,50 A TRAVERS TOUT
 R3,10 ∇ 1.15

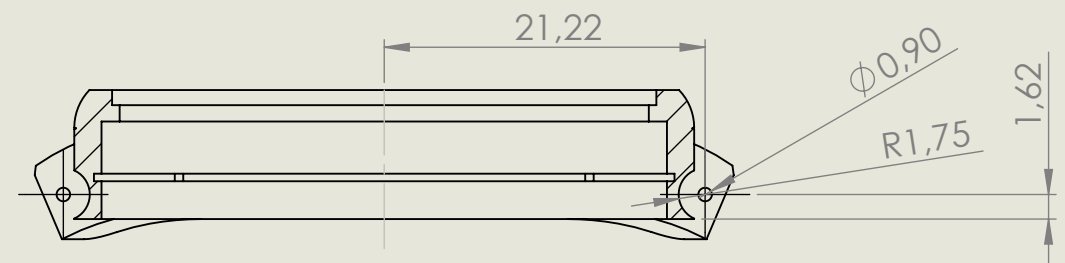
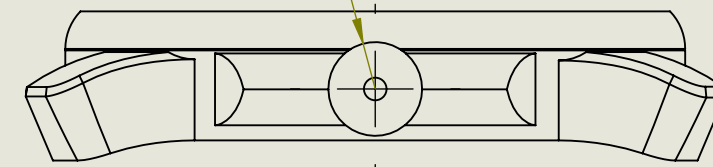

COUPE C-C

SAUF INDICATION CONTRAIRE: LES COTES SONT EN MILLIMETRES ETAT DE SURFACE: TOLERANCES: LINEAIRES: ANGULAIRES:		FINITION:		CASSER LES ANGLES VIFS		NE PAS CHANGER L'ECHELLE		REVISION	
AUTEUR		SIGNATURE		DATE		TITRE:			
VERIF.									
APPR.									
FAB.									
QUAL.				MATERIAU:		No. DE PLAN			
						carrure mise en plan		A3	
				MASSE:		ECHELLE:2:1		FEUILLE 1 SUR 1	