

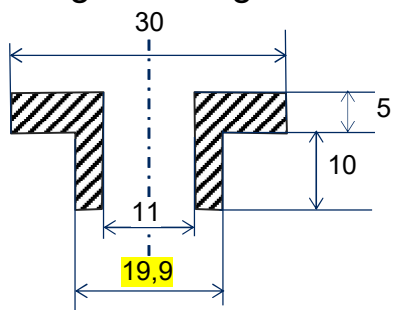

Bague blocage 20

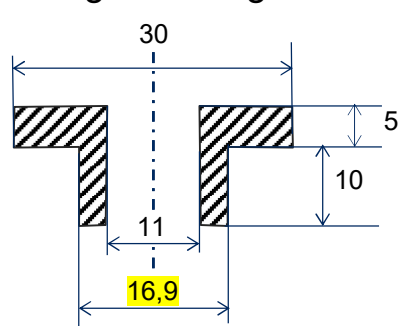

Bague blocage 17



Entretoise 23

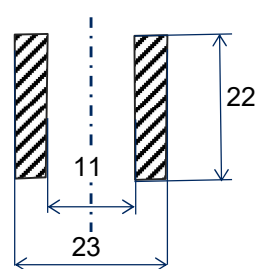

Acier d'usinage standard pour bagues et entretoise
Alu pour les embouts d'extraction et insertion
Tolérance générale $\pm 0,1$
Toutes cotes en mm
Les dessins ne sont pas à l'échelle

Chiffrage pour 7 pièces (1 de chaque)

Embout extraction 17

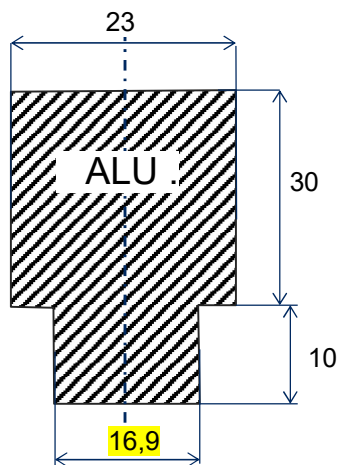

Embout insertion 17

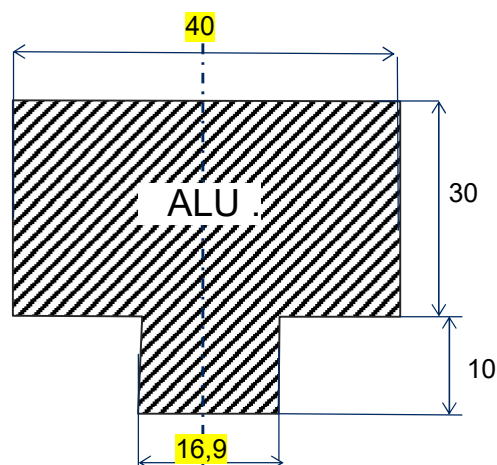

Embout extraction 20

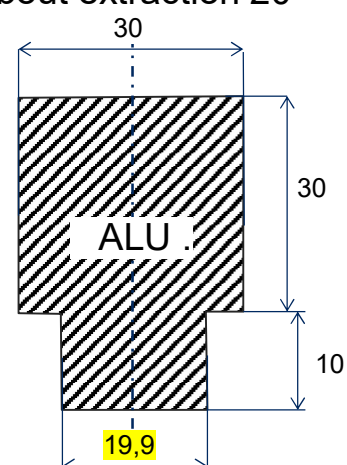

Embout insertion 20

