

CHANFREINS PERIPHERIQUES = 1mm

CHANFREINS PERIPHERIQUES = 1mm

TOLERANCES D'USINAGE : ± 0.1 mm

A-A

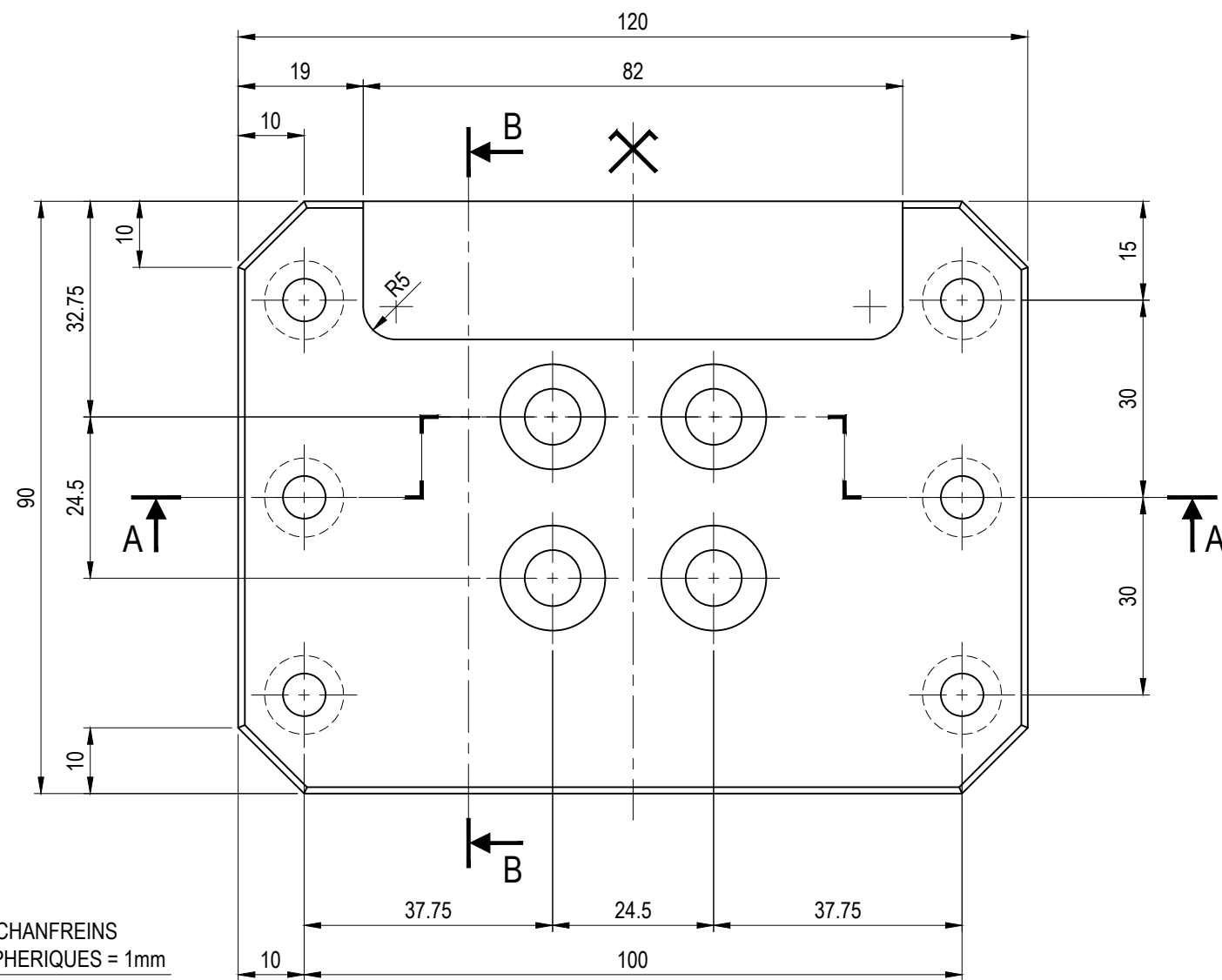
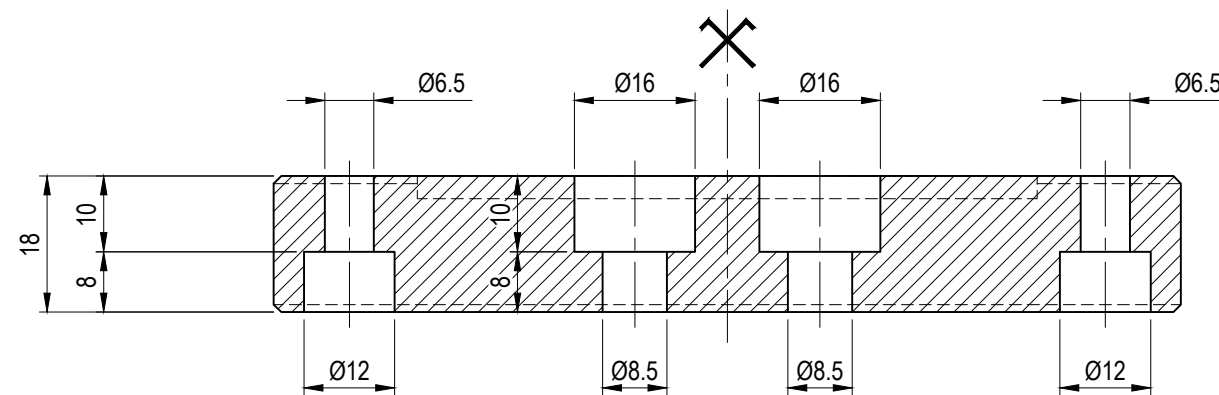

Echelle	1:1	PLATINE D'ADAPTATION POUR MONTURE AZ		Plan : n°	01
				Partie :	1/1
Quantité :	1	PLAN DE FABRICATION		Révision :	00
Repère :	-			Date :	2020-09-02
Matière :	ALUMINIUM	Finition :	BRUTE	Nom :	TREMERIE Guillaume