

# Wizart Factory

---

## Plans du modèle Horloge Infinie

1 Ensemble = 6 pièces

06 Août 2023

Usinage 1 (fraisage)  
Cf. fichier .step



Essence :  
Chêne  
Hêtre  
....

Usinage 1 (fraisage)  
Cf. fichier .step

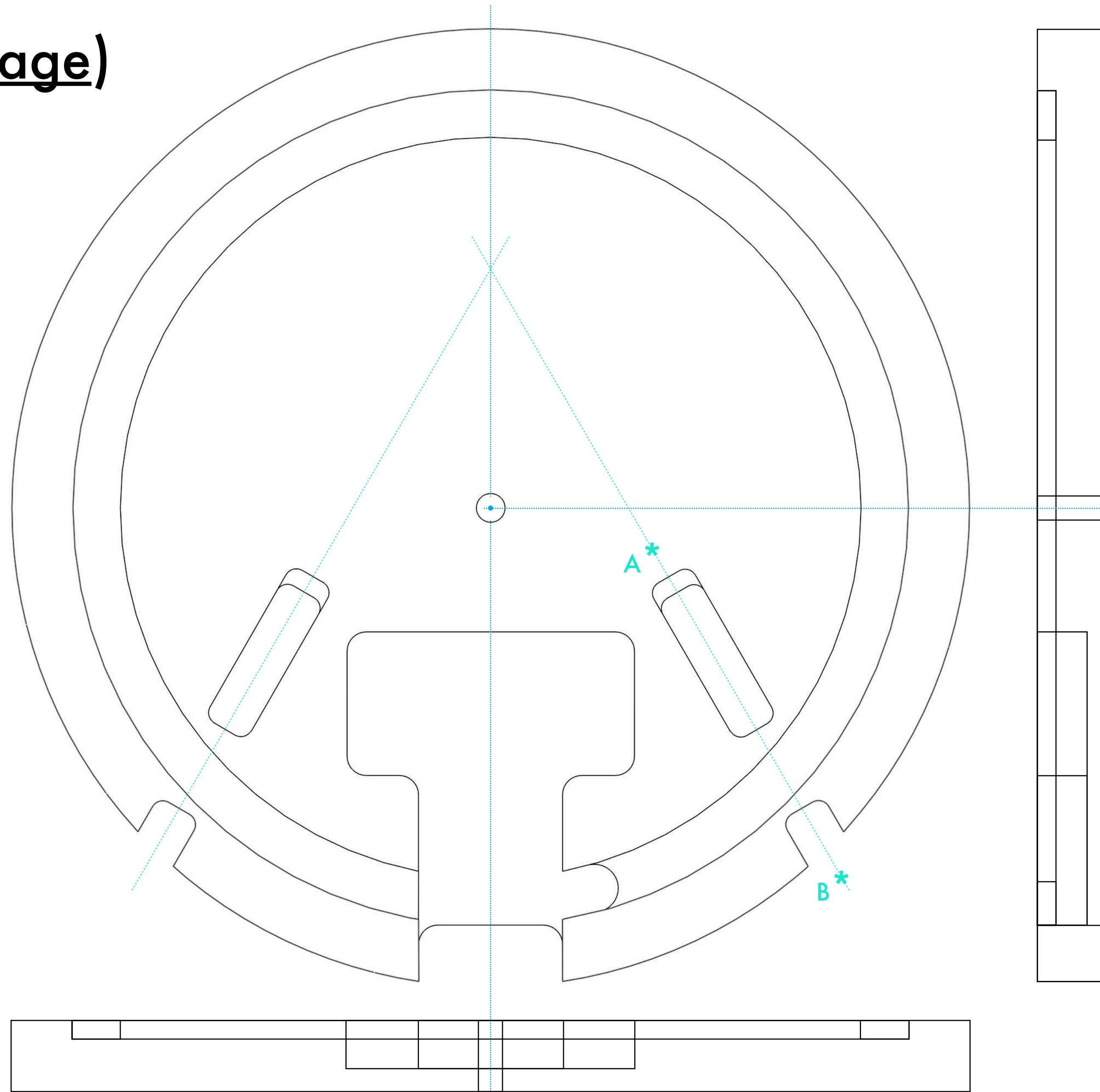

\*Plan de coupe A-B

Essence :  
Chêne  
Hêtre  
....

Usinage 1 (fraisage)  
 Cf. fichier .step  
 (en mm)

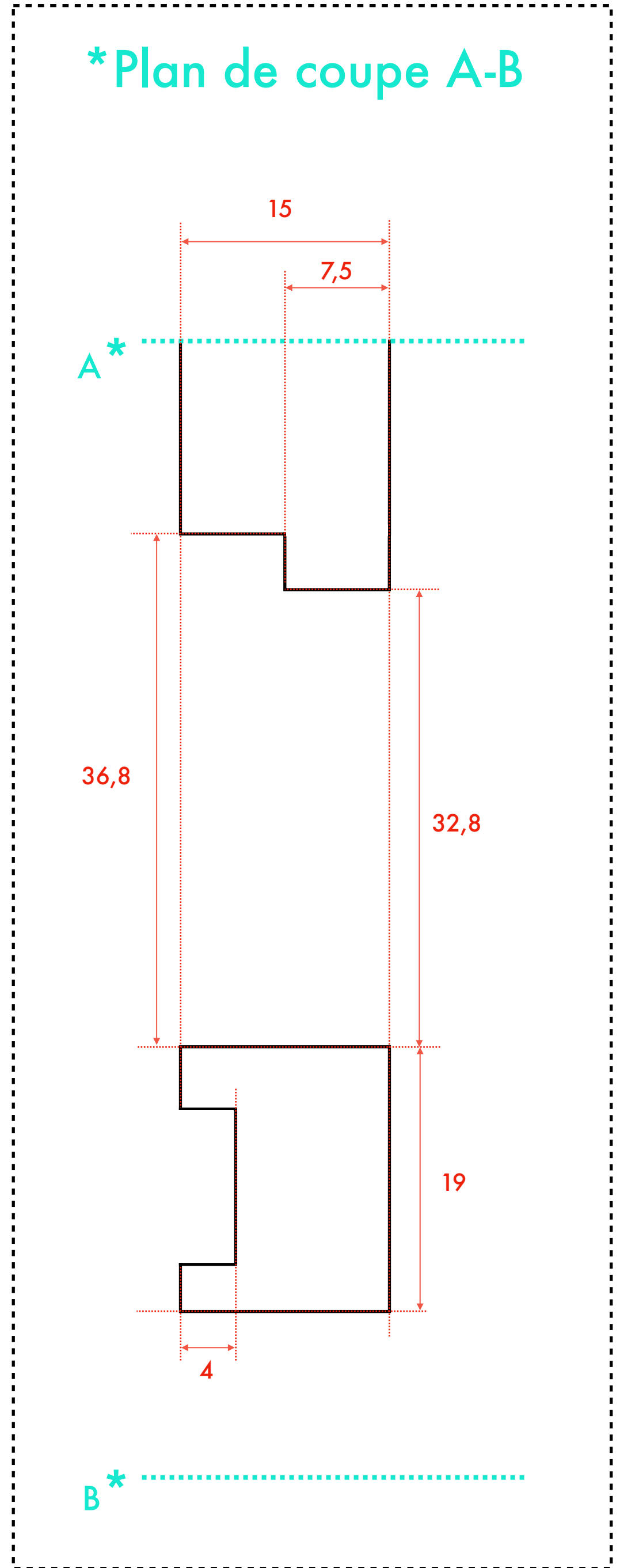
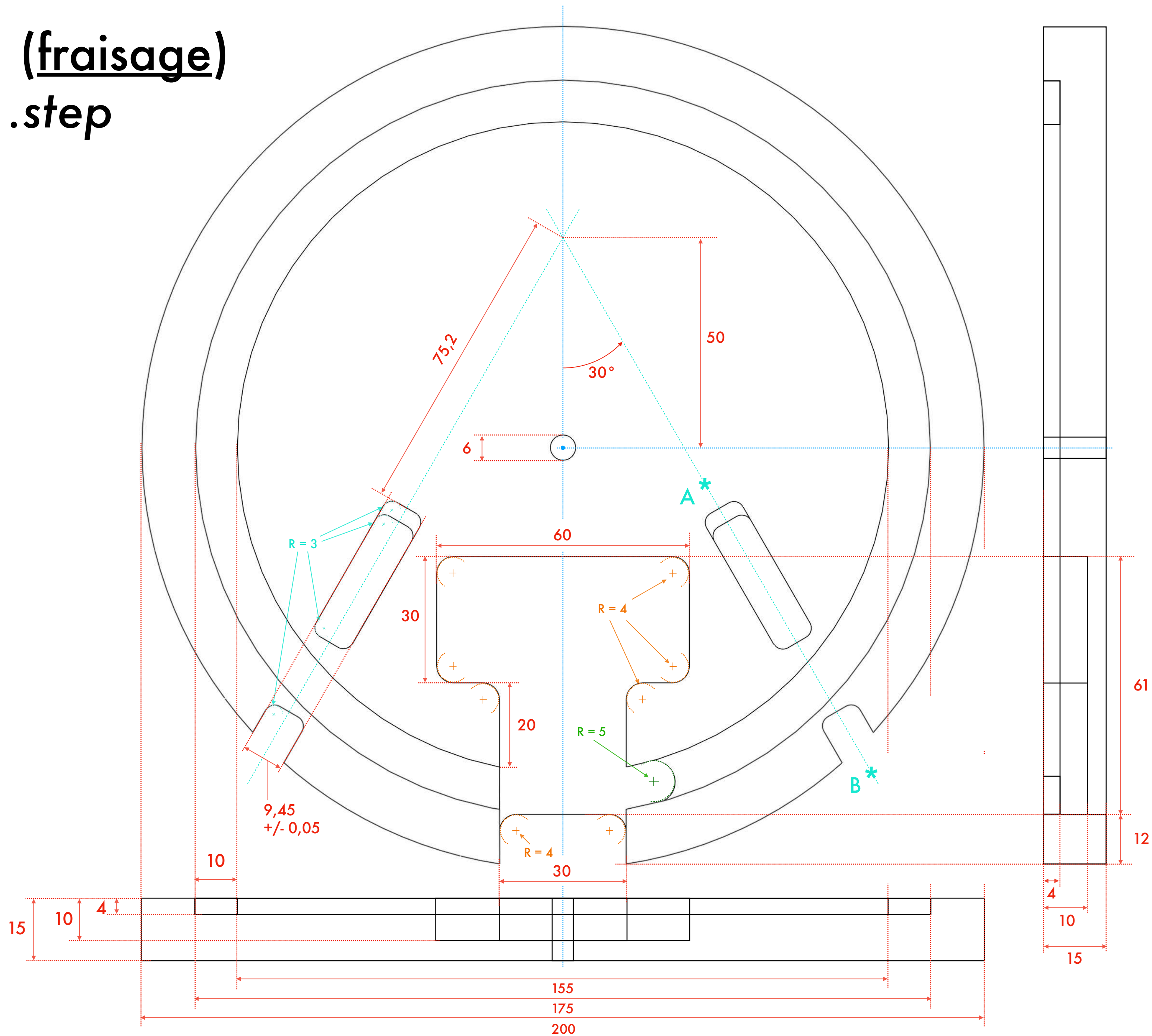

Essence :  
 Chêne  
 Hêtre  
 ....

Usinage 2 (fraisage)  
(x2)

Usinage 2.1



Usinage 2.2



**Essence :**

Chêne

Hêtre

....

# Usinage 2.1 (fraisage)

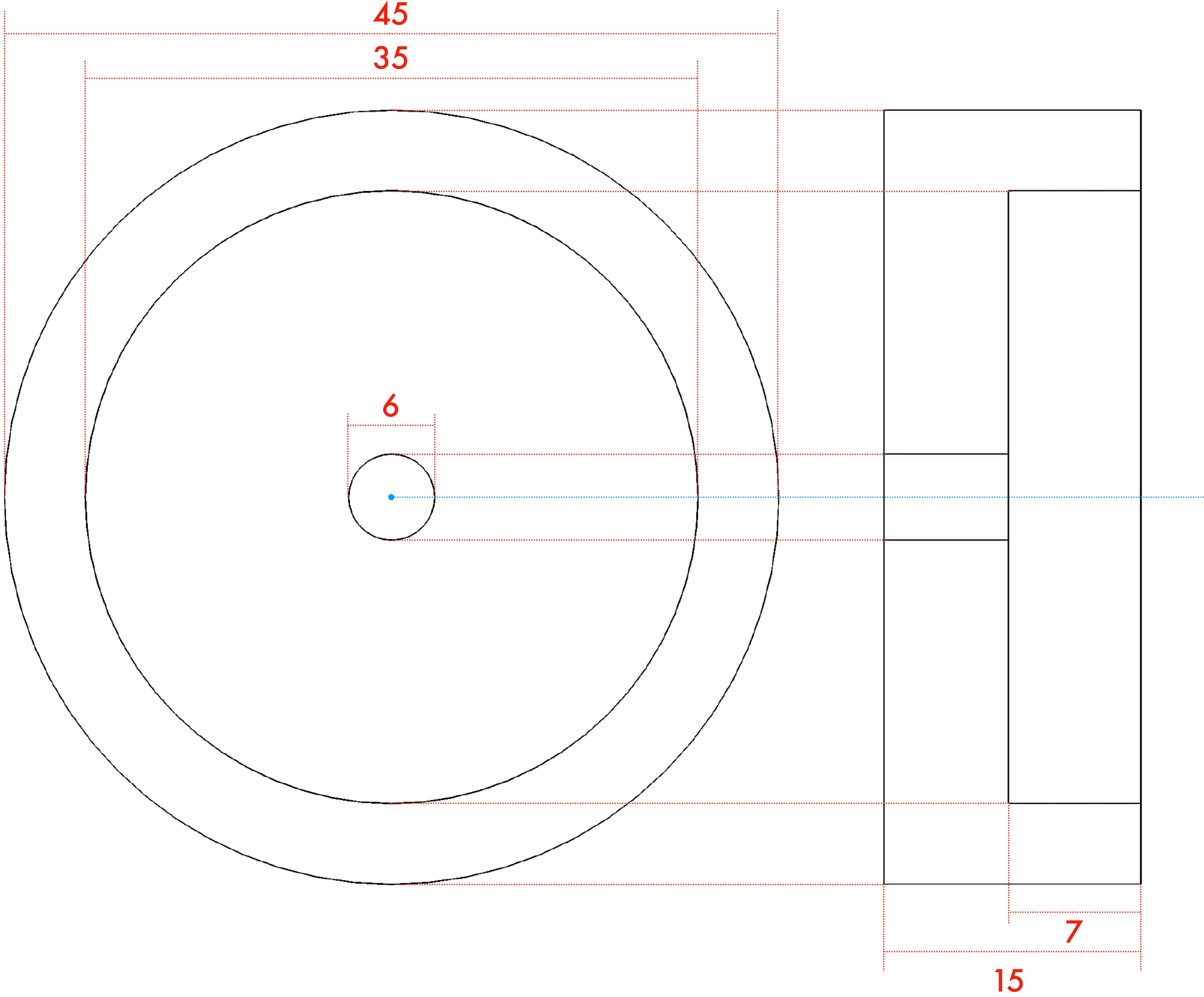

**Essence :**

Chêne

Hêtre

....

# Usinage 2.2 (fraisage)

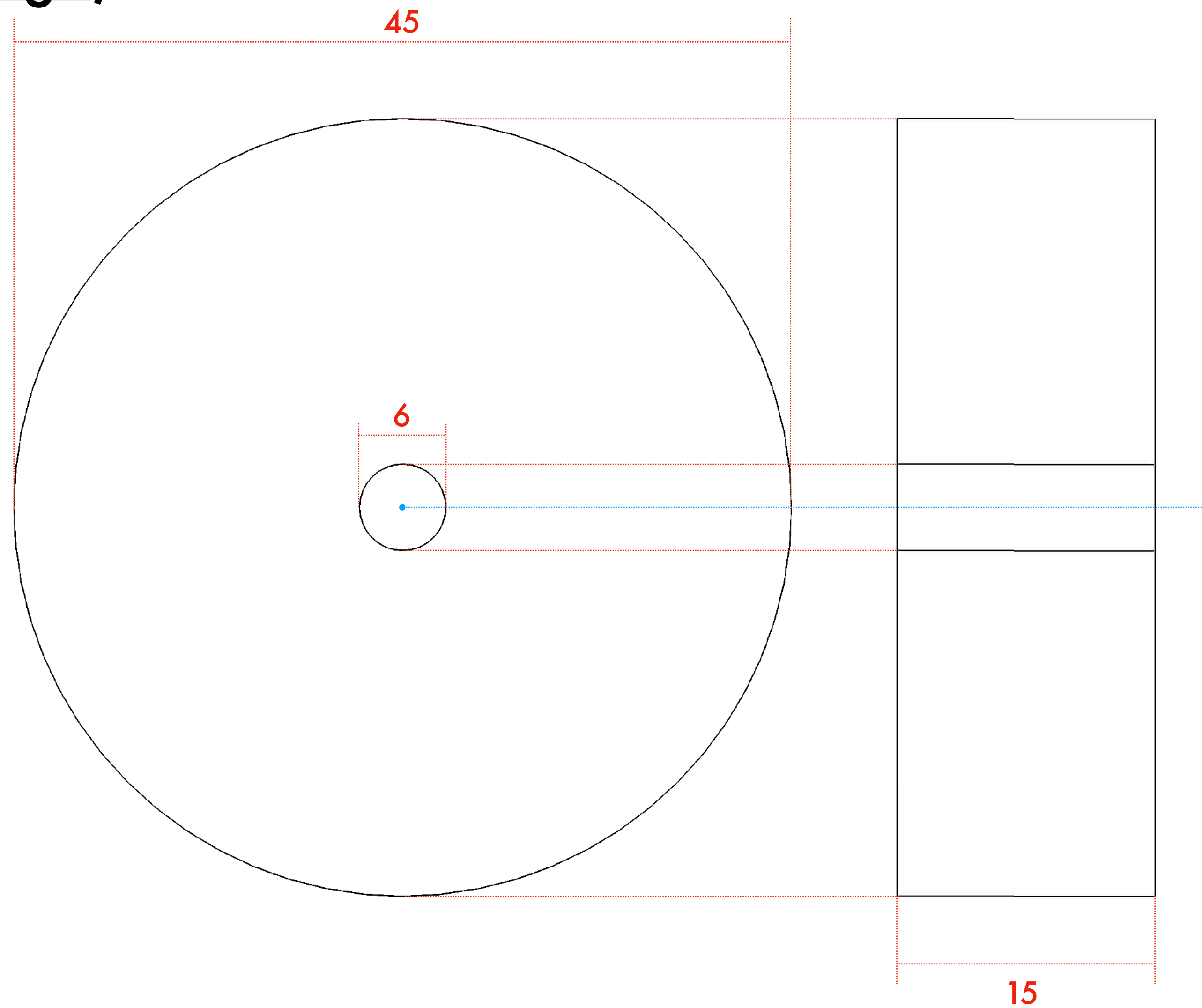

**Essence :**

Chêne

Hêtre

....

# Usinage 3 (fraisage)

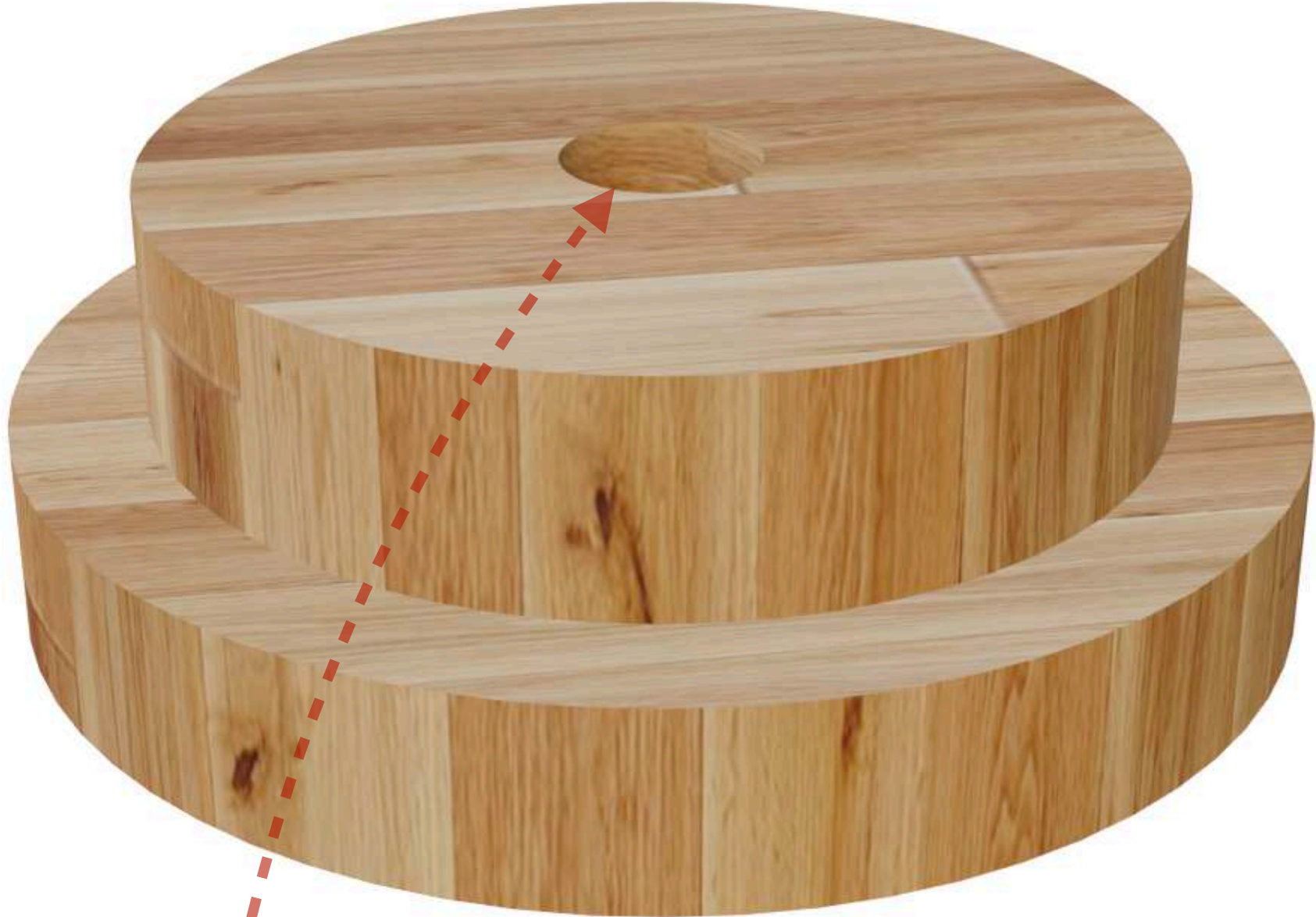

Essence :  
Chêne  
Hêtre

....



**Usinage 3 (fraisage)**  
**(en mm)**

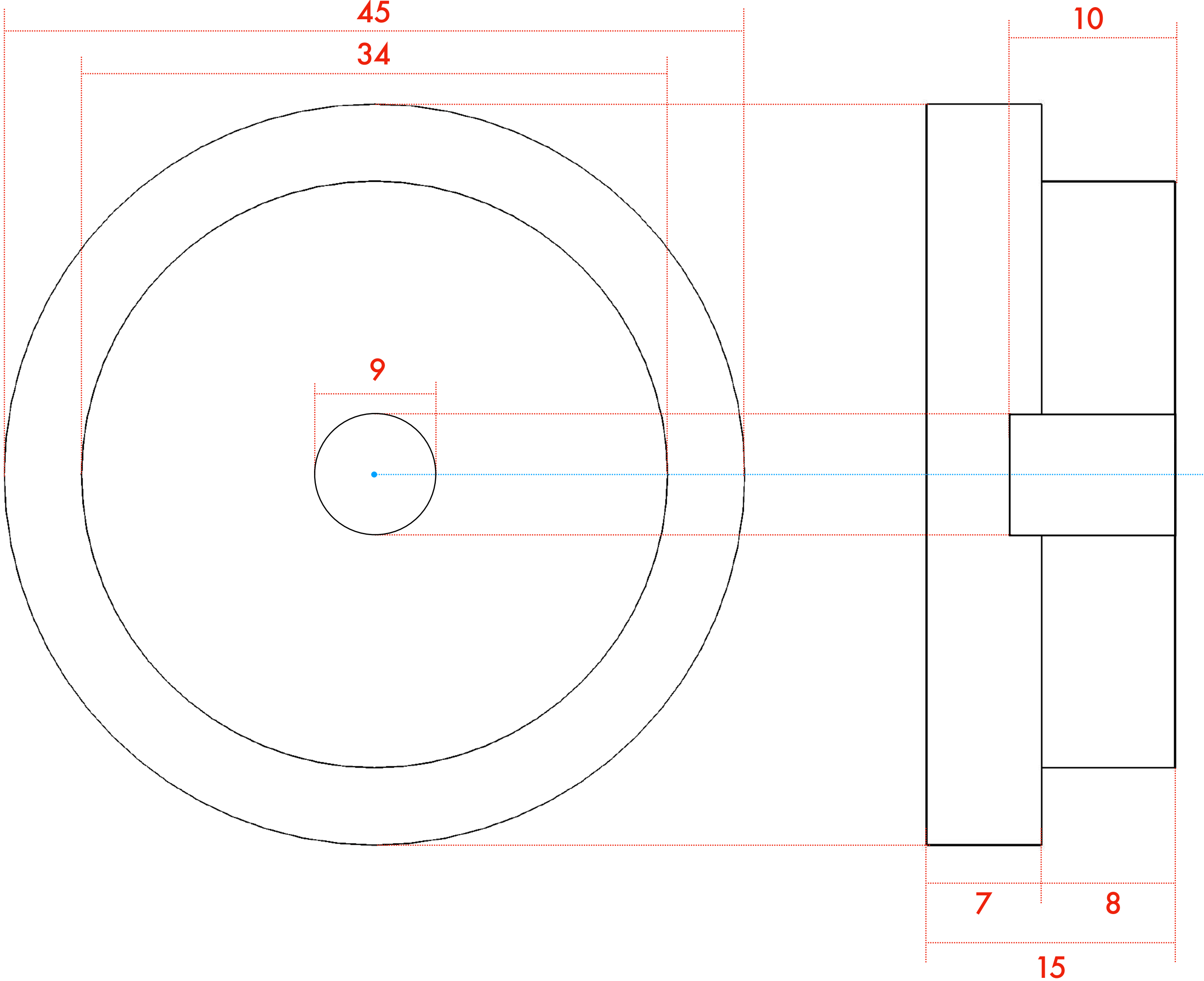

**Essence :**  
Chêne  
Hêtre  
....

Usinage 4 (LASER)  
(x2)  
Cf. fichier .dxf/.ai

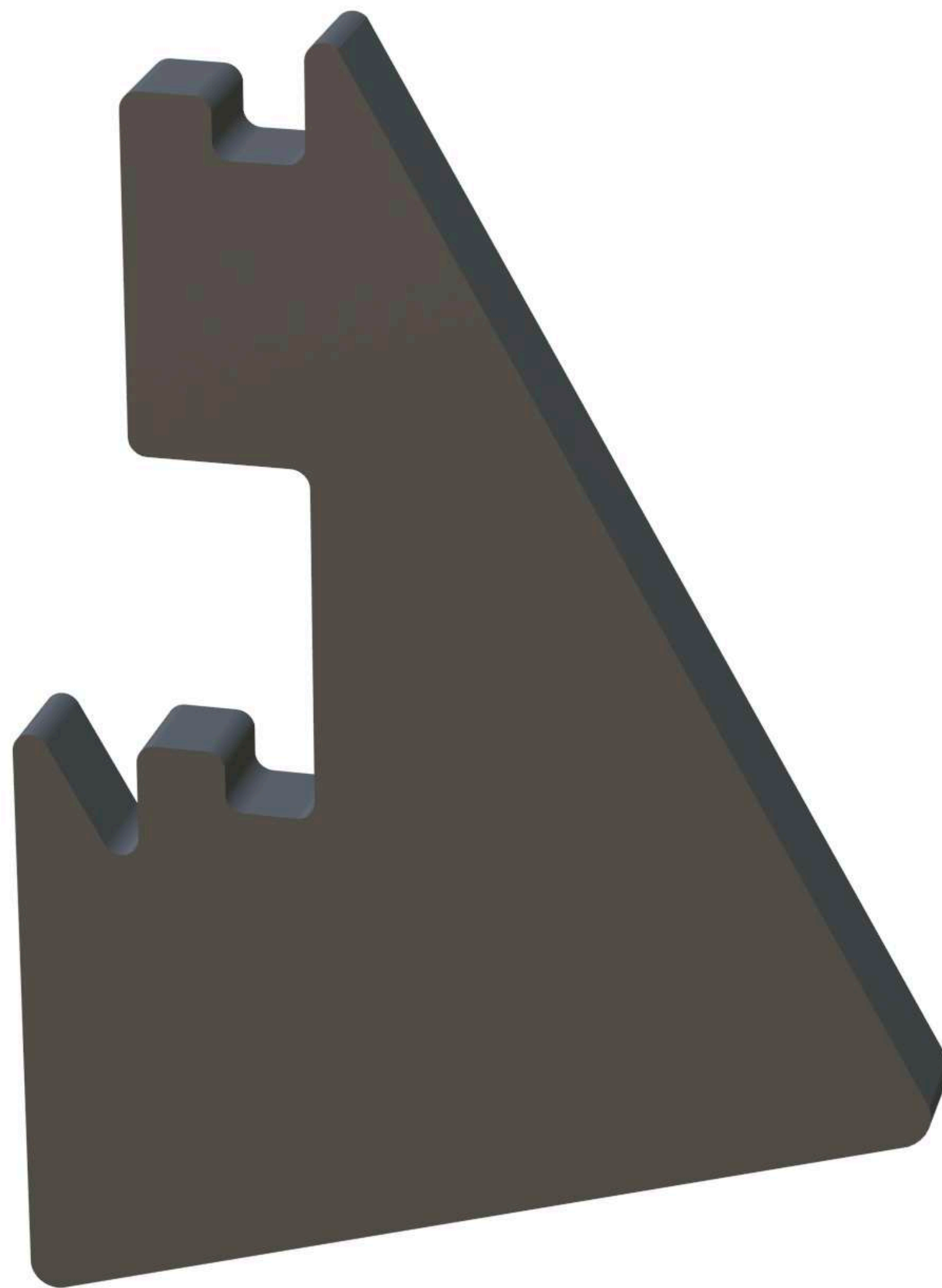

Essence :  
MDF Noir  
9mm

Pièces complémentaires

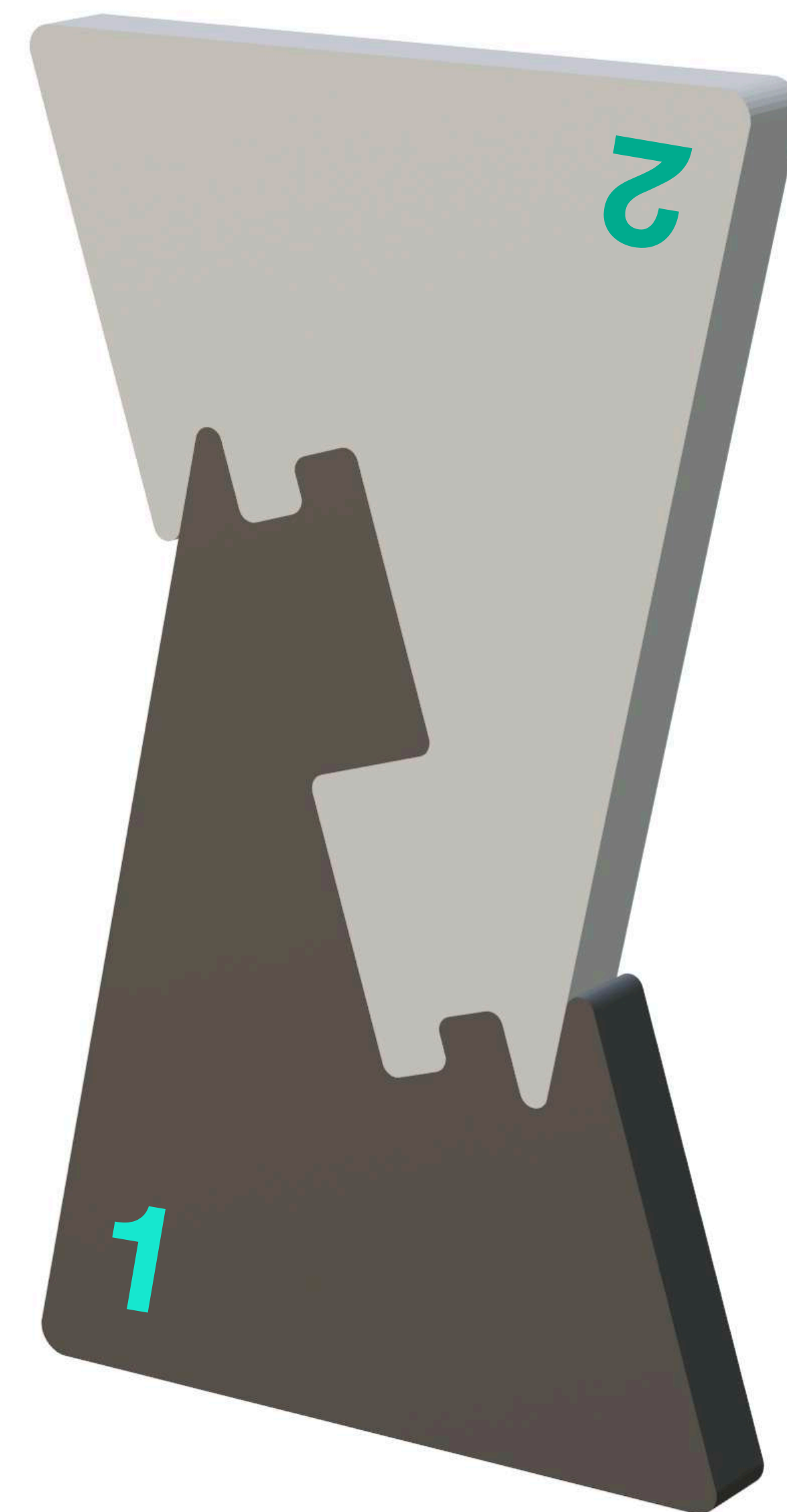

Usinage 4 (LASER)  
(x2)  
Cf. fichier .dxf/.ai  
(en mm)

Essence :  
MDF Noir  
9mm

