

8 7 6 5 4 3 2 1

F
E
D
C
B
A

F
E
D
C
B
A

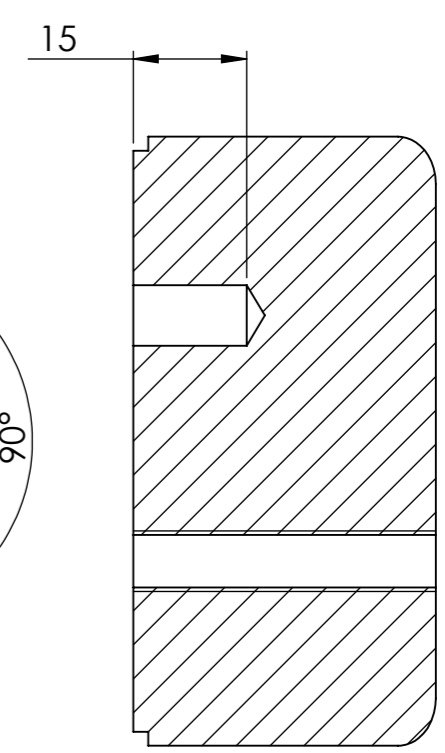
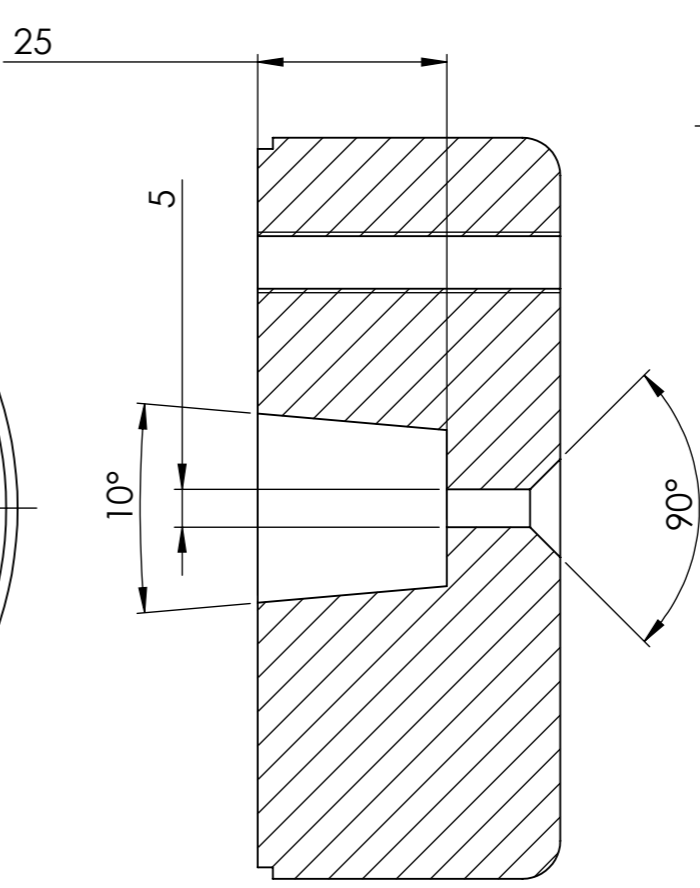
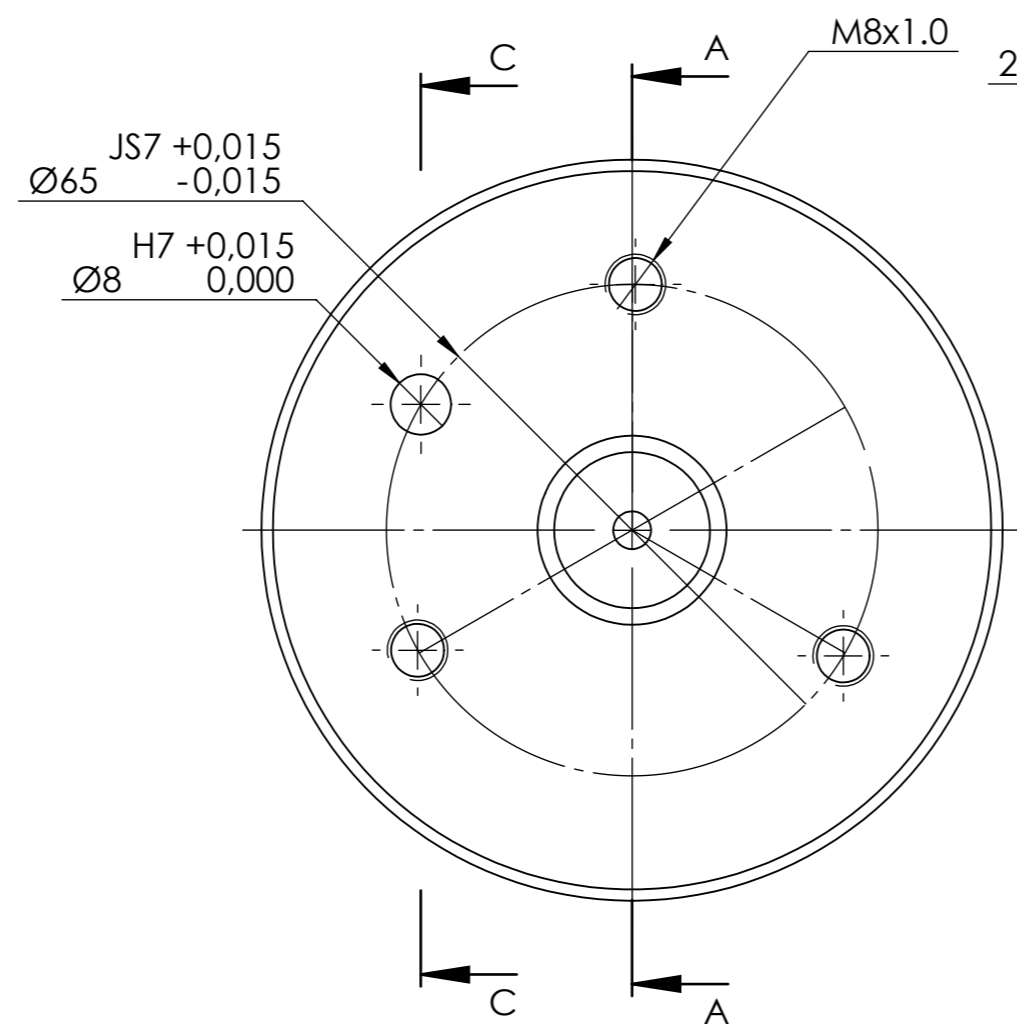
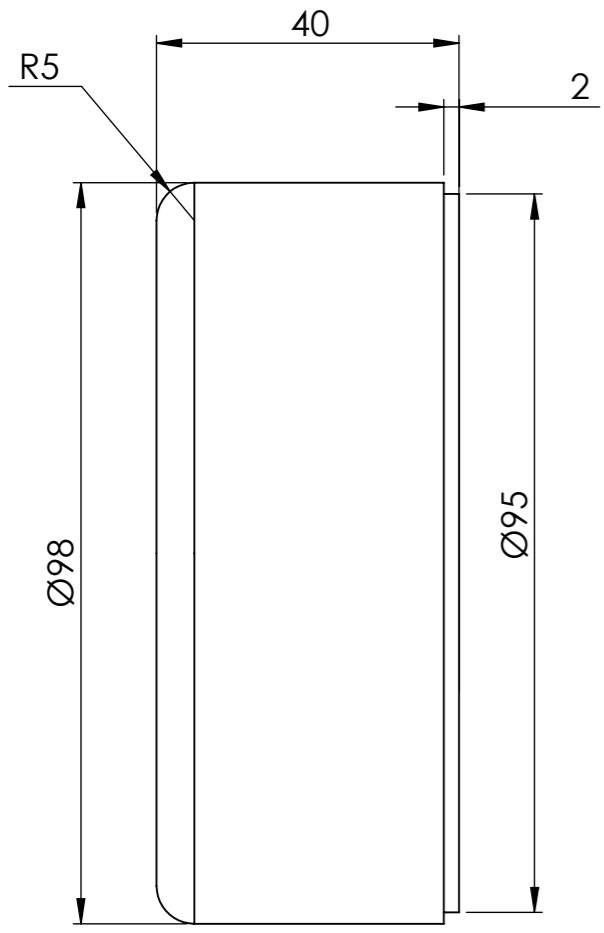

COUPE A-A

COUPE C-C

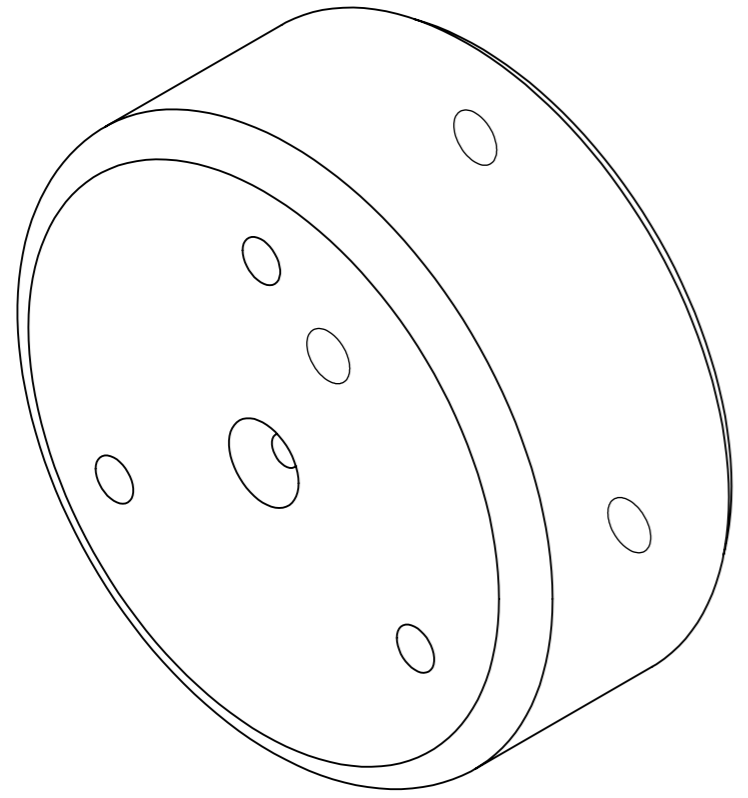

ATELIER
DES RECYCLEURS FOUS

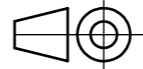
Weight		Material	
kg		ALU	
Machine		Description	
INJECTEUSE		MOULE PORTE MANTEAU	
Projection method:		Release date	Drawing no.
First angle 		07/2023	MPM0002
General tolerances		Doc. type	Rev.
ISO 2768-m		Part	A
Units unless specified	Sheet size	Scale	Sheet
mm	A3	1:1	1 / 1

8 7 6 5 4 3 2 1