

8 7 6 5 4 3 2 1

F F E E D D C C B B A A

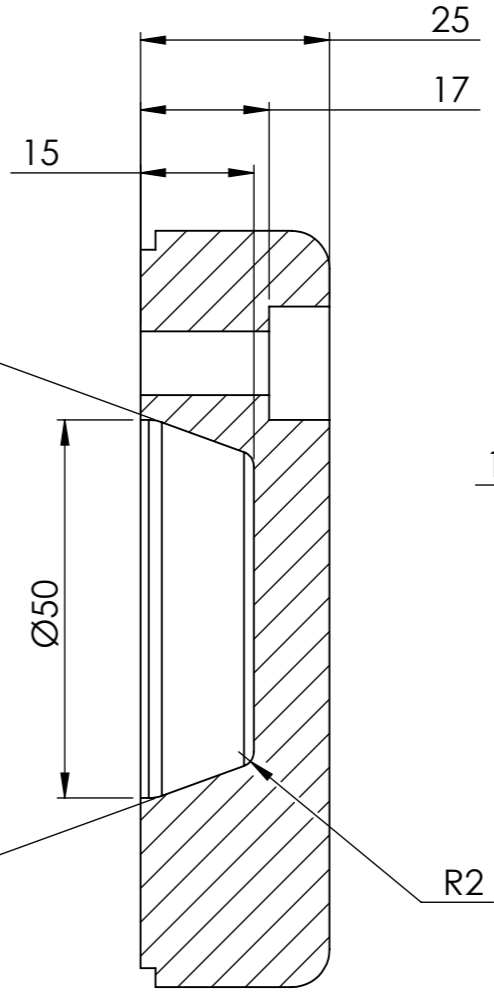

COUPE A-A

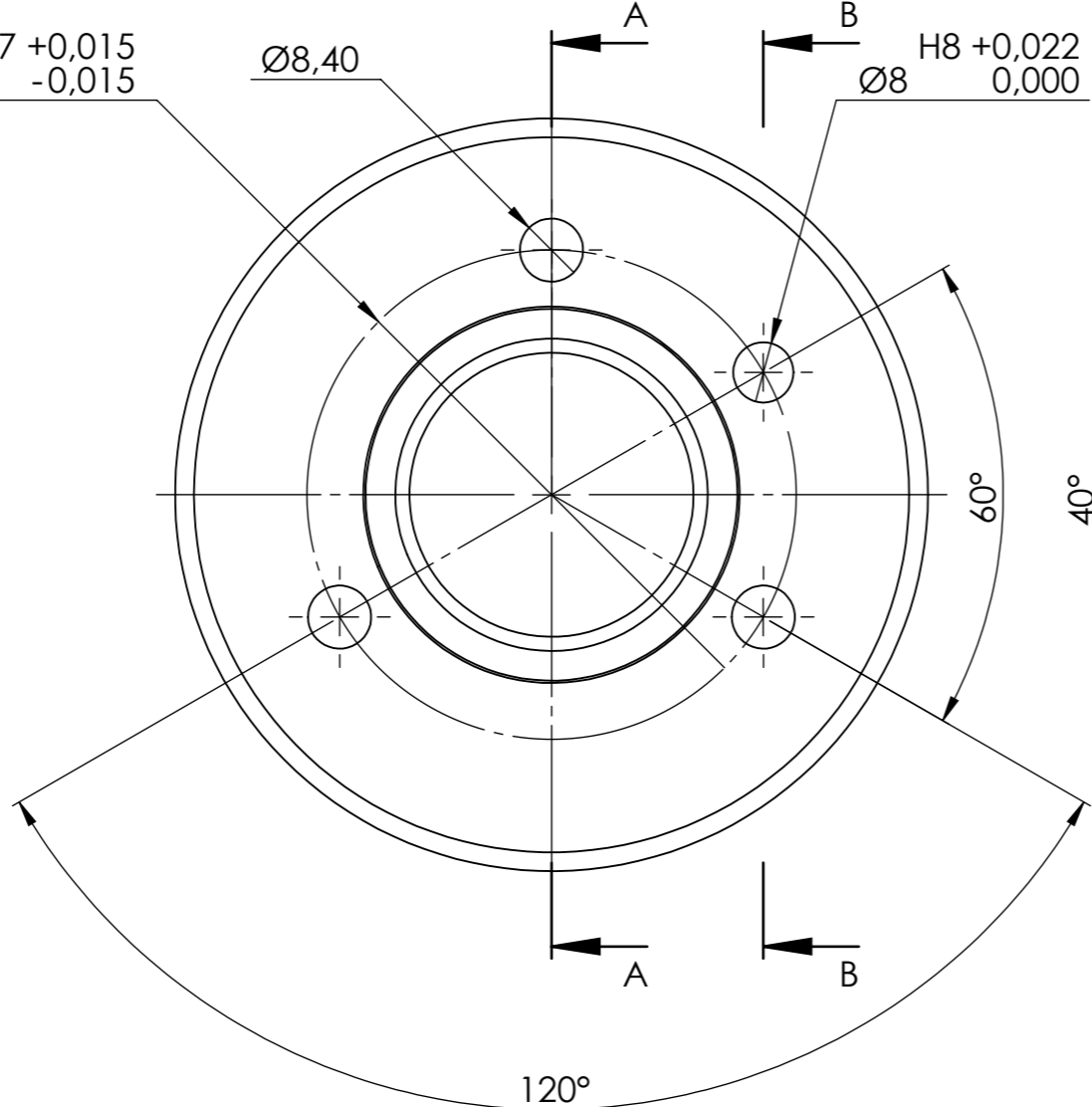
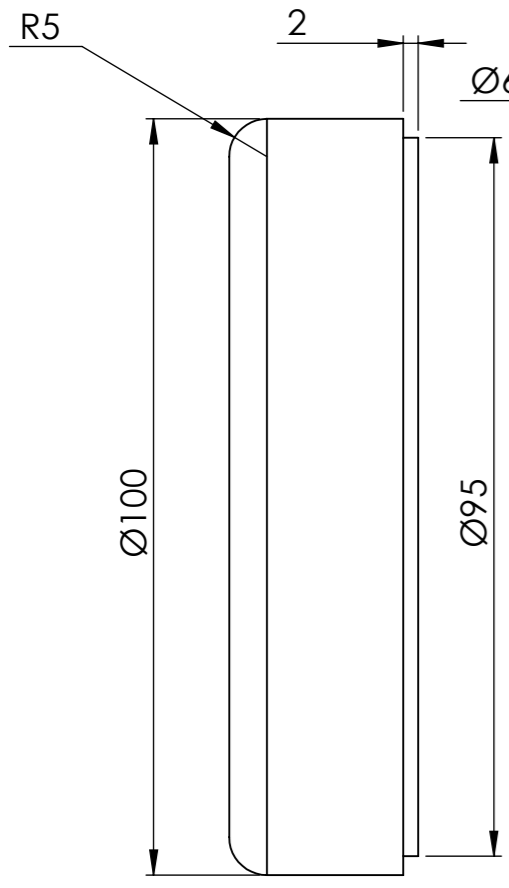
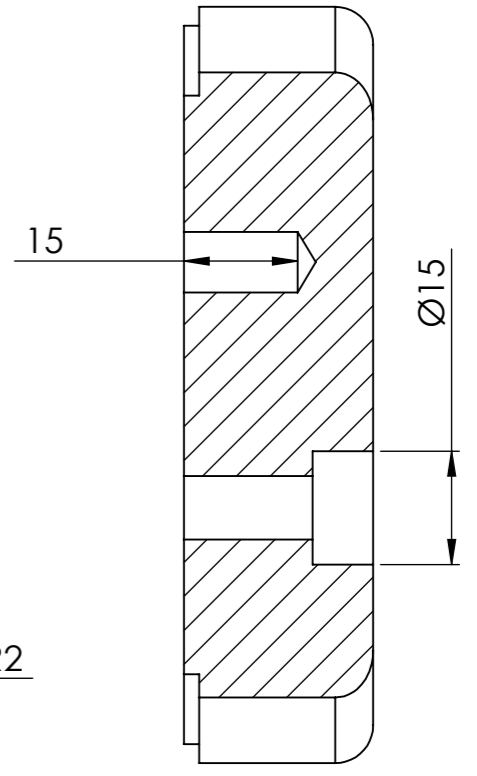

COUPE B-B

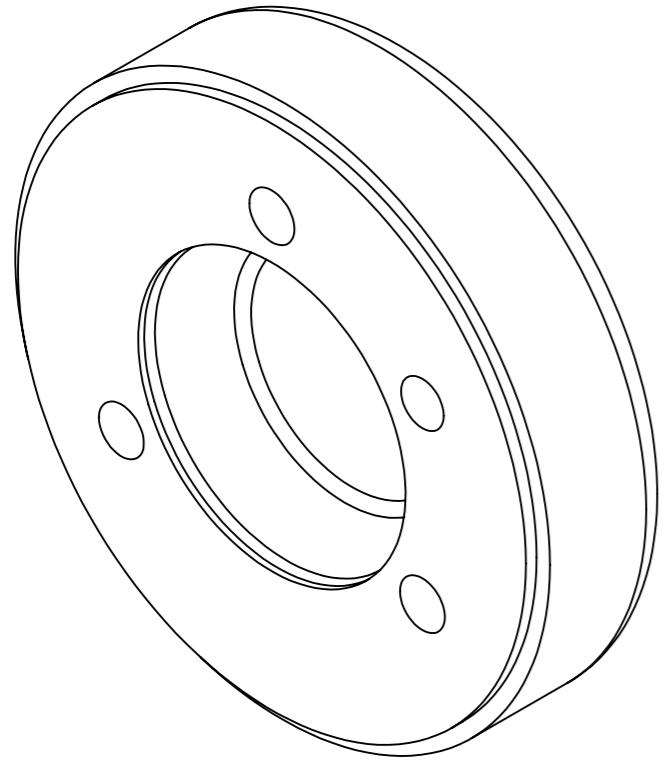

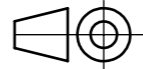
Weight		Material	
kg		ALU	
Machine		Description	
INJECTEUSE		MOULE PORTE MANTEAU	
Projection method:		Release date	Drawing no.
First angle 		07/2023	MPM0001
General tolerances		Doc. type	Units unless specified
ISO 2768-m		Part	mm
		Sheet size	Scale
		A3	1:1
		Rev.	Sheet
		A	1 / 1

8 7 6 5 4 3 2 1

A A B B C C D D E E F F