

Section A-A

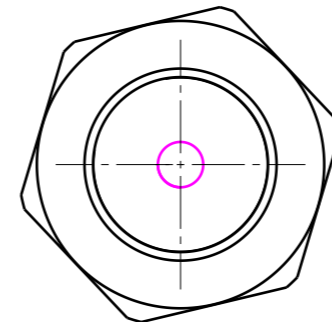
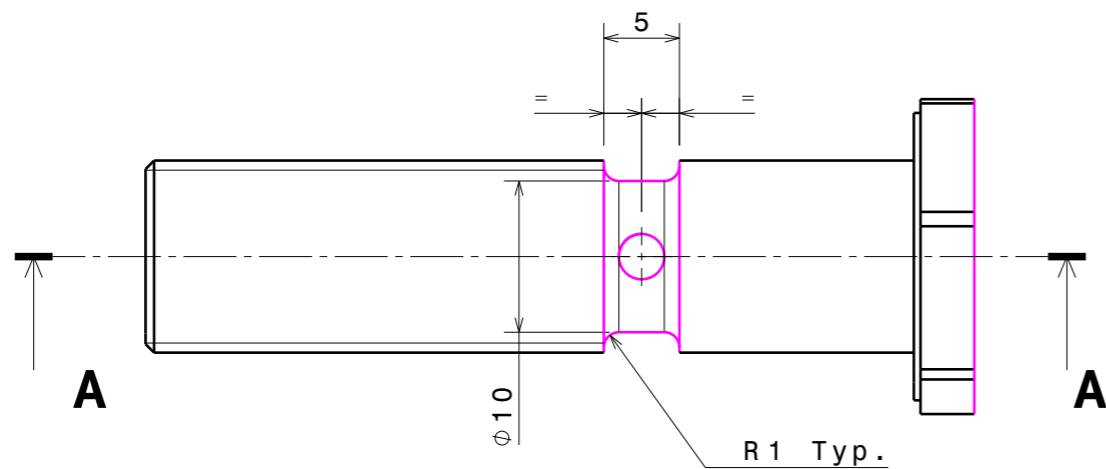
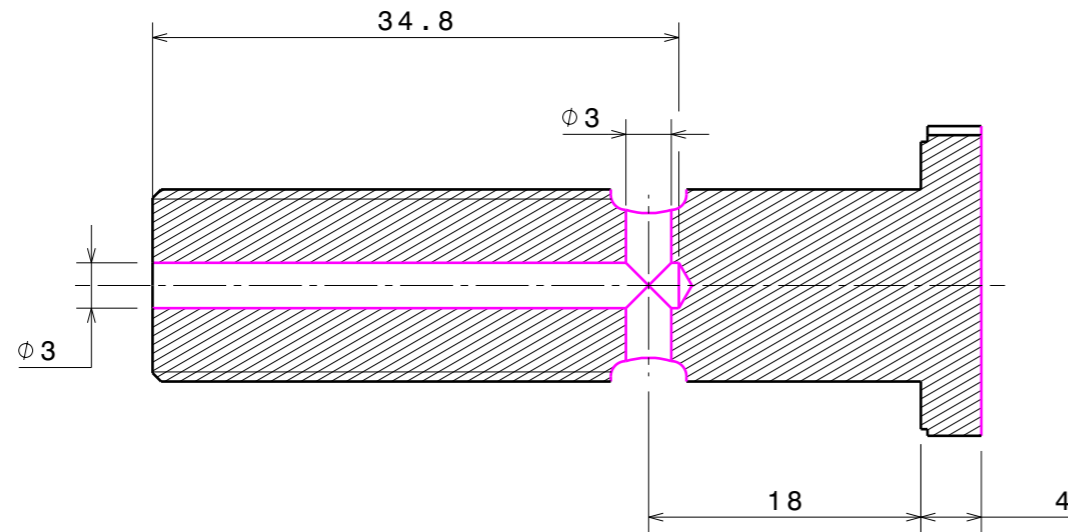

VIS - RFL

- PLAN Ech. 2:1

- TOLERANCE SUR LES COTES : $\pm 0.1\text{mm}$

- QUANTITE 2

- PIECE A REALISER DANS VIS ACIER TETE H CLASSE 10.9

1/2-13UNC x 2'' TYPE ANSI B18-2-1 ou equivalent FINITION LIBRE

- Fourniture vis à discuter