

Material :

Acier S 235 ou equivalent.

Heat treatment :

Protection of surf :

✓ Unless Otherwise Indicated

Suppression des bavures et angle tranchant | Removal of blurr and sharp angle

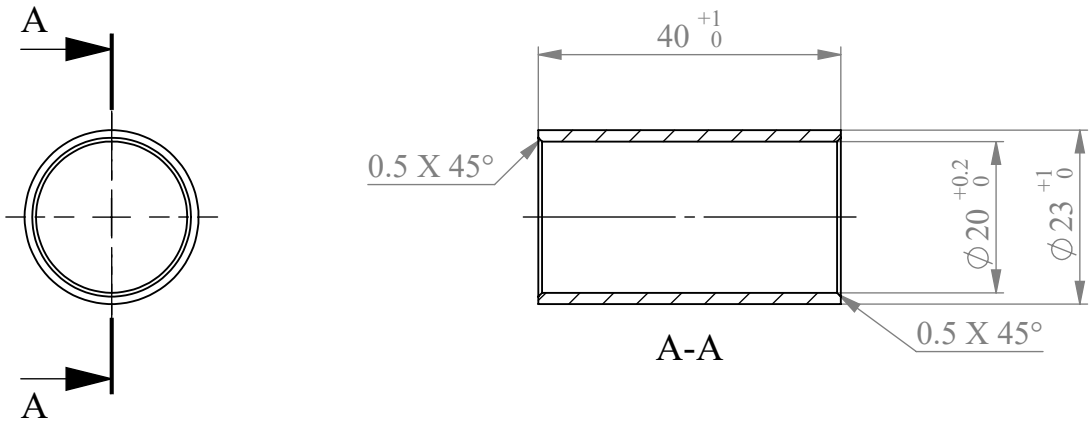

EXEPT OTHER INDICATION

General tolerances to be respected :
 ISO 2768 : m & k
 Welding : v
 Sheet Metal : v
 Mould : ISO 8062
 Surface texture : ISO 1302
 Welding Symbols : ISO 2553

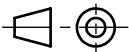

CAUTION :
 All dimensions are in millimeters and projected view in ISO std

Mod	Date	By	Modifications

Mass (Kg) :
0.0

Legacy ID

manchon TdB

Drawing Number

Rev :

DTM Class :

Sheet :

Size : A4

Scale : 1:1

Units : mm

SOLIDWORKS

1/1