

COUPE A-A

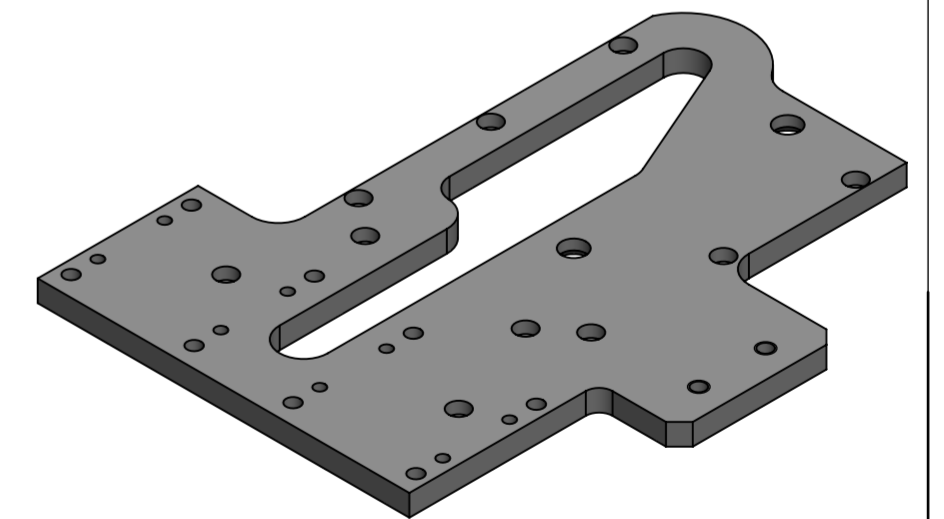
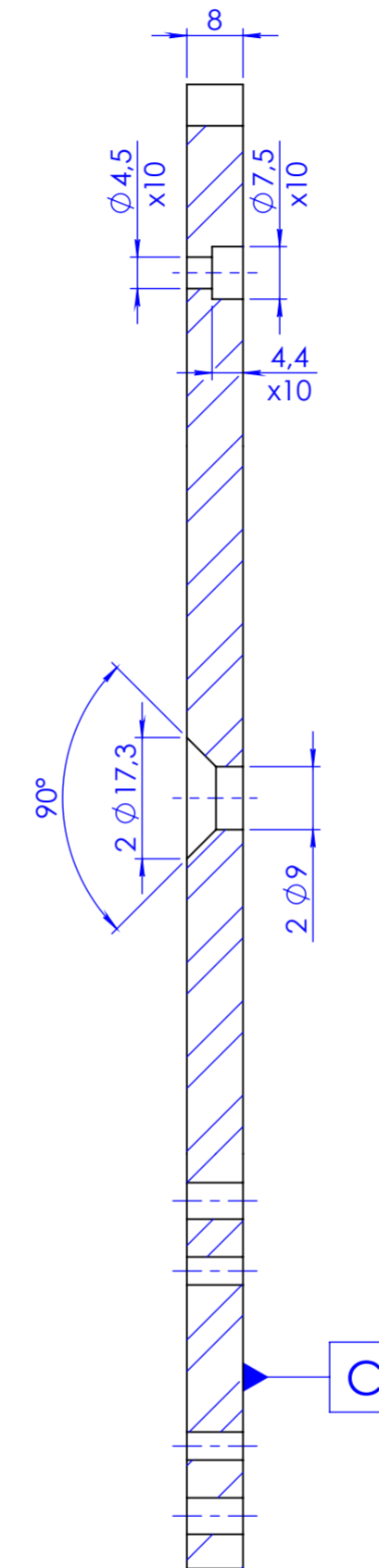

QUANTITE: 1

Etabli par : <b>J. Fatoux</b>	<b>ANODISATION</b> Traitement	NOTA: Tolérance générale: JS13; js13 Rugosité générale: Ra 3.2
Vérifié par : <b>J. Fatoux</b>		
Date : <b>22/05/2022</b>	<b>2017-A</b> Materiau	
Format : <b>A2</b>		
Echelle : <b>1:1</b>	<b>K4-PLAQUE DE BASE</b> Numero	Indice
Masse : <b>Kg</b>		
		<b>1 / 1</b> Feuille