

perçage taraudage M5x7.5mm

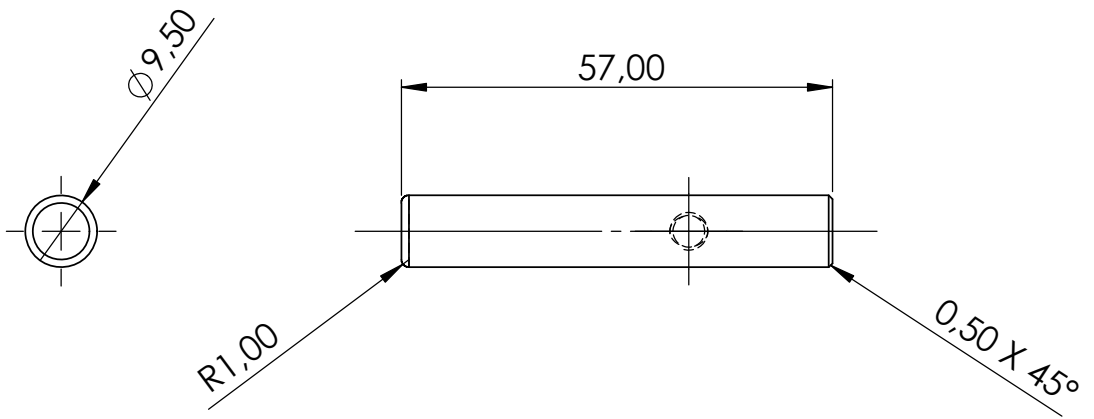

SAUF INDICATION CONTRAIRE:
LES COTES SONT EN MILLIMETRES
ETAT DE SURFACE:
TOLERANCES iso 2768-mk

FINITION:

CASSER LES
ANGLES VIFS

NE PAS CHANGER L'ECHELLE

REVISION 00

NOM		DATE	MATERIAU:	No. DE PLAN	A4
AUTEUR	Clément Jégou	19/02/22	inox 316L	axe banquette 2cv inox 316L	
MASSE:			ECHELLE:1:1	FEUILLE 1 SUR 1	