

4 3 2 1

F

F

E

E

D

D

C

C

B

B

A

A

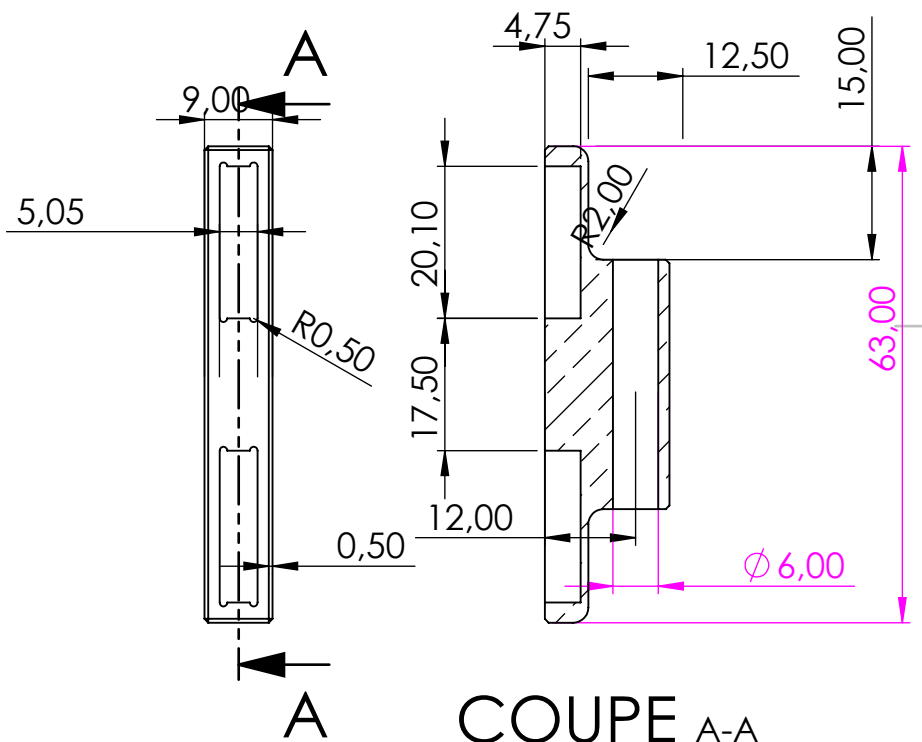
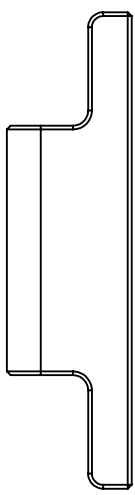
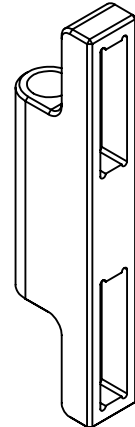

SAUF INDICATION CONTRAIRE:
LES COTES SONT EN MILLIMETRES
ETAT DE SURFACE:
TOLERANCES:
LINEAIRES:
ANGULAIRES:

FINITION:

CASSER LES
ANGLES VIFS

NE PAS CHANGER L'ECHELLE

REVISION

	NOM	SIGNATURE	DATE
AUTEUR			
VERIF.			
APPR.			
FAB.			
QUAL.			

TITRE:
F5-08.01.02.02-Support_aimant-V01-17.5mm

MATERIAU:

No. DE PLAN

A4

MASSE: g

ECHELLE:1:1

FEUILLE 1 SUR 1

4 3 2 1