

COUPE A-A

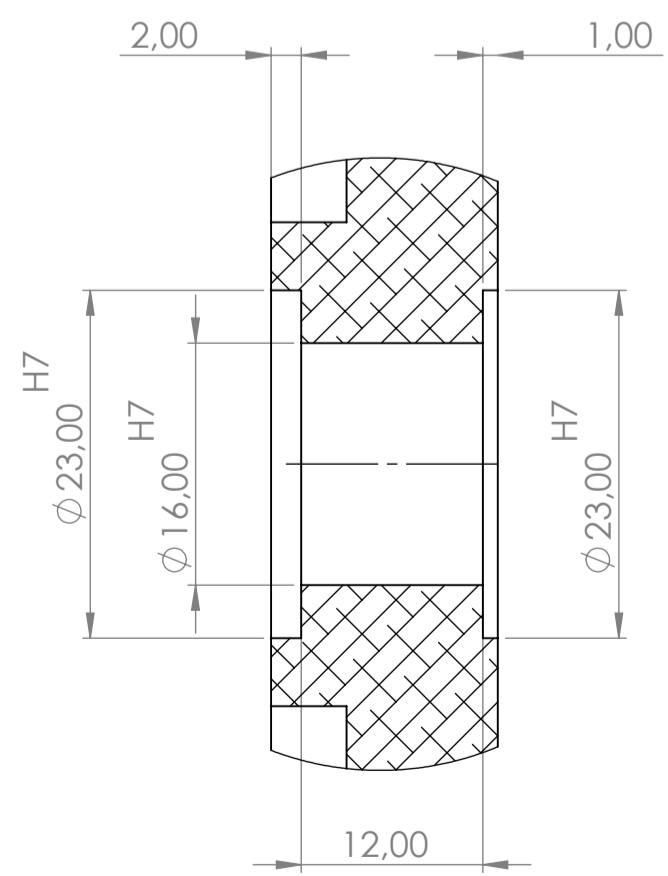
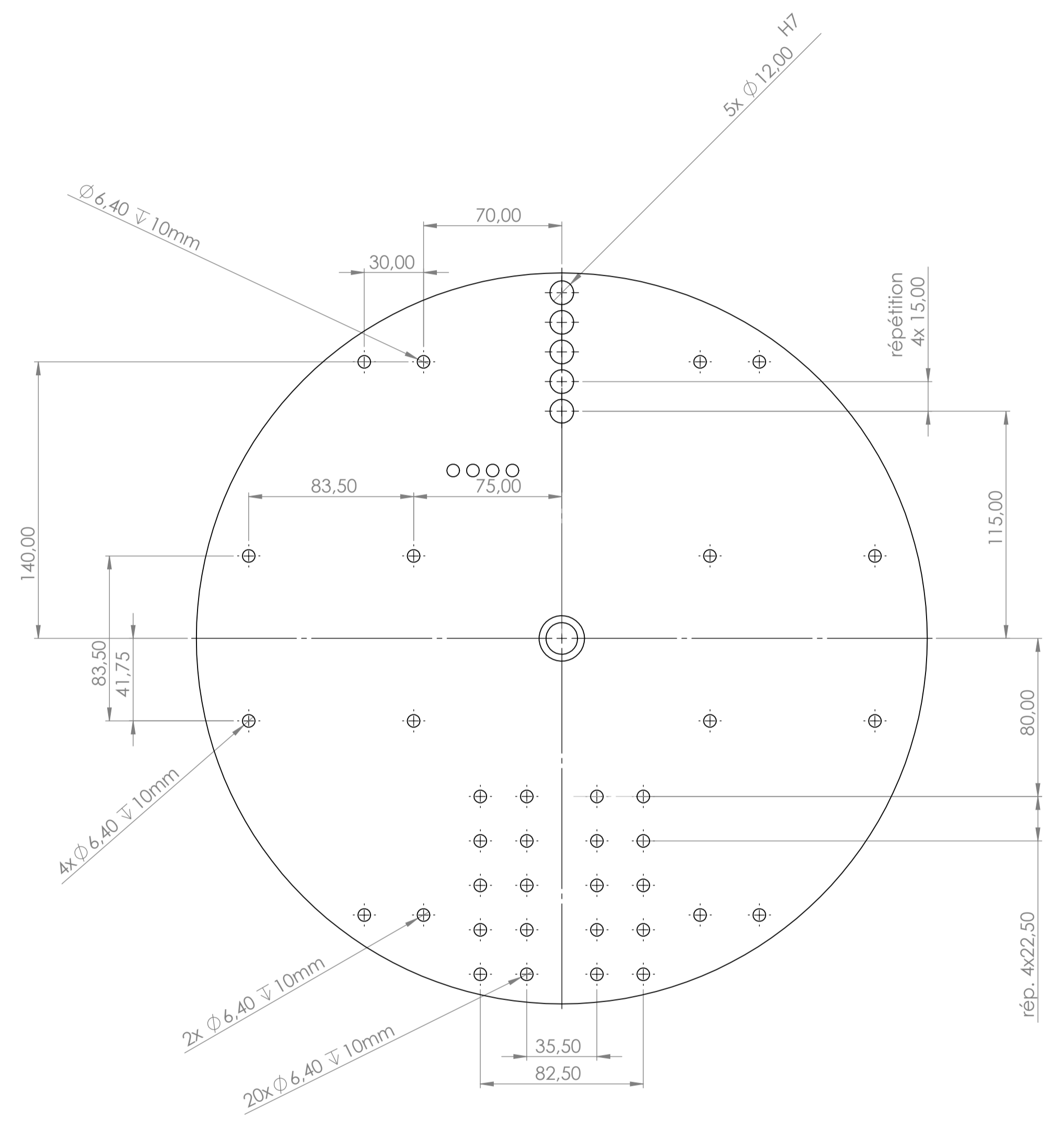

DÉTAIL B
ECHELLE 2 : 1

Spécifications générales / General specifications		DIMENSIONS EN MILLIMÈTRES - LA COTATION EST DÉFINIE APRÈS TRAITEMENT ARÊTES VIVES MICHES 0,2 A 45° - RAYONS D'OUTILS ADMIS 0,4 DIMENSIONS ARE IN MILLIMETER - DIMENSIONS DEFINED AFTER TREATMENT SHARP EDGES CHAMFERED 0,2 A 45° - TOOL RADIUS 0,4 ADMITTED		PROJET / PROJECT :
ISO2768-mK $\sqrt{Ra 3.2}$				CONSTANT G
MATIÈRE / MATERIAL : Alliage 2024		MASSE / WEIGHT (kg) : 4359.87		
TRAITEMENT / TREATMENT :		chassis		
NOM / NAME : FB		DATE Création : 31/05/2020	ECH. / SCALE : 1:2	
REF. P1-062020			FORMAT	FOLI
			A1	1/1
<small>CE DOCUMENT EST LA PROPRIÉTÉ DE FBPC. IL NE PEUT ÊTRE NI COMMUNIQUÉ À DES TIERS, NI REPRODUIT SANS L'AUTORISATION PRÉALABLE ÉCRITE DE FBPC. THIS DOCUMENT IS THE EXCLUSIVE PROPERTY OF FBPC. IT MUST BE COMMUNICATED TO THIRD PARTIES OR REPRODUCED WITHOUT WRITTEN AUTHORIZATION FROM FBPC.</small>				