

Bend Table			
ID	Direction	Angle	Radius
1	Up	90.00	2.00
2	Up	90.00	2.00
3	Down	90.00	2.00
4	Up	90.00	2.00
5	Down	90.00	2.00

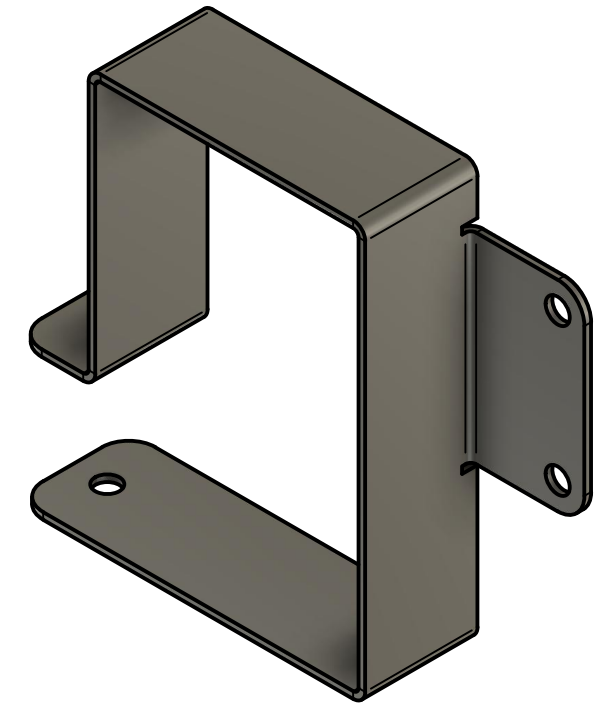

- Epaisseur de tôle = 2,5mm
- Angle des pliages = 90°
- Rayon des pliages = 2mm
- Congé des coins = 10mm
- Diamètre des 4 trous = 9mm

- Sheet thickness = 2,5mm
- Bends angle = 90°
- Bends radius = 2mm
- Corners fillet = 10mm
- Diameter of the 4 holes = 9mm

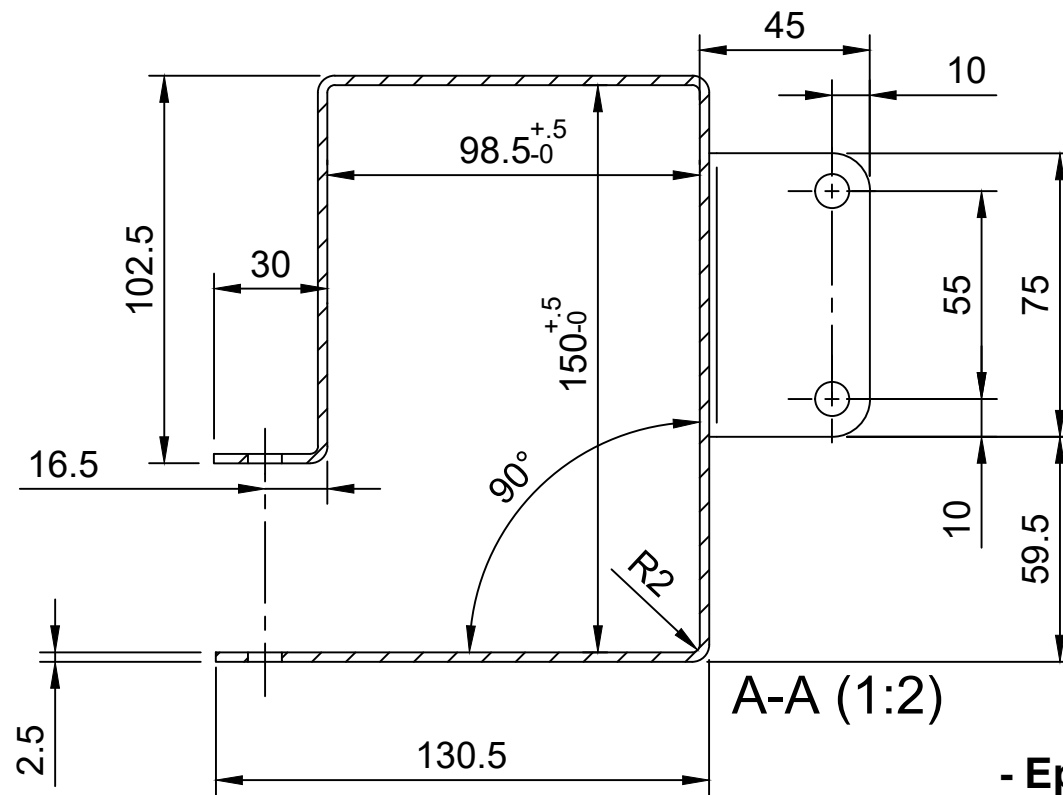
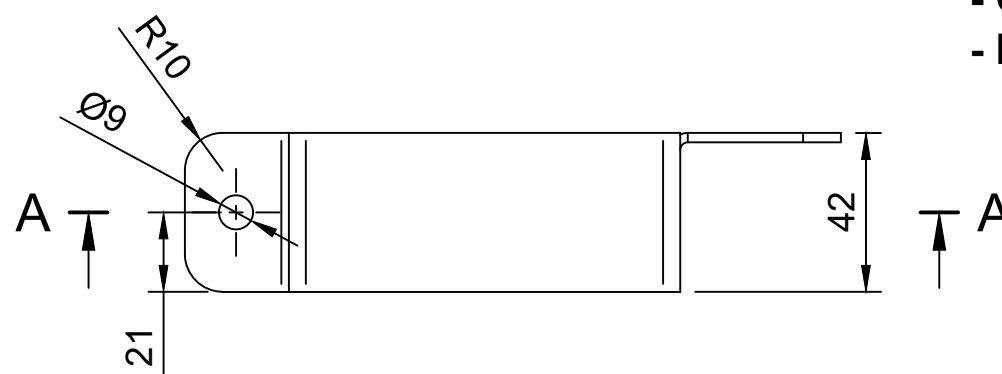

Material = Stainless steel (Acier inoxydable)

Dept.	Technical reference	Created by <b>Antonin</b>	18/05/2020	Approved by
		Document type	Document status	
		Title <b>Blocage Transversal</b>	DWG No.	
Ech 1:2		Rev.	Date of issue	Sheet <b>1/1</b>