

Conçu par L DUVOID	Vérifié par	Approuvé par	Date	Date 23/04/2020
QUANTITE: x1 - PLASTIQUE ABC		GALET POUSSEUR		
		GALET-pousseur	Modification	Feuille 1 / 1

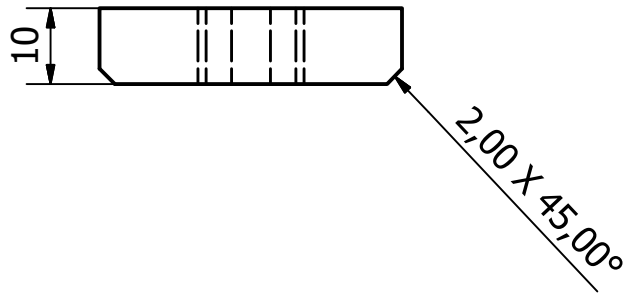

Conçu par L DUVOID	Vérifié par	Approuvé par	Date	Date 23/04/2020
QUANTITE: x1 - MATIERE AU4G		LIAISON		
		liaison	Modification	Feuille 1 / 1

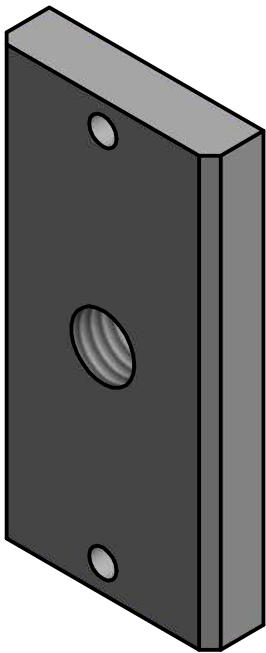
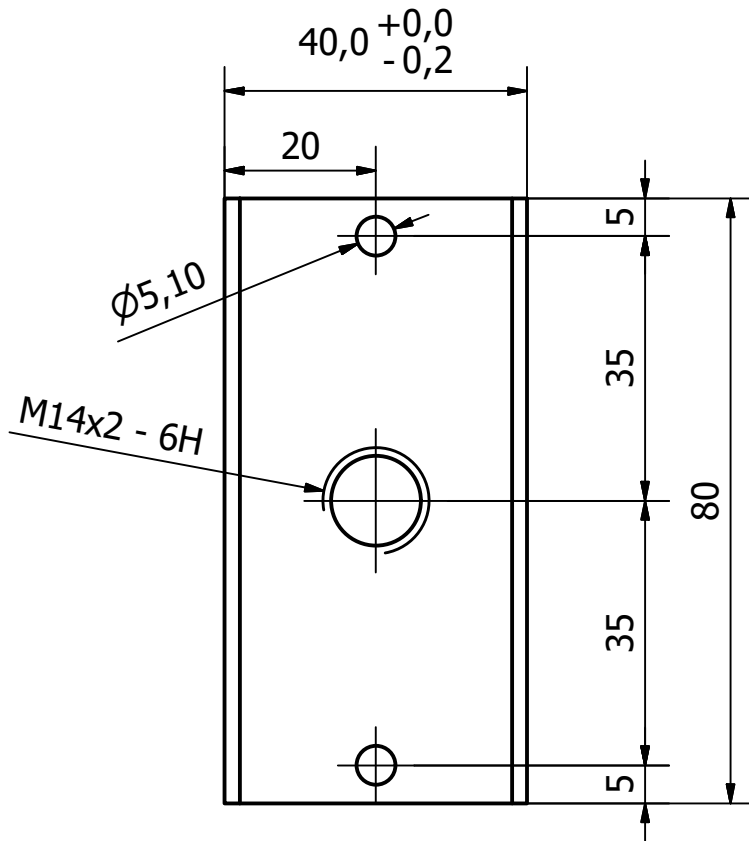
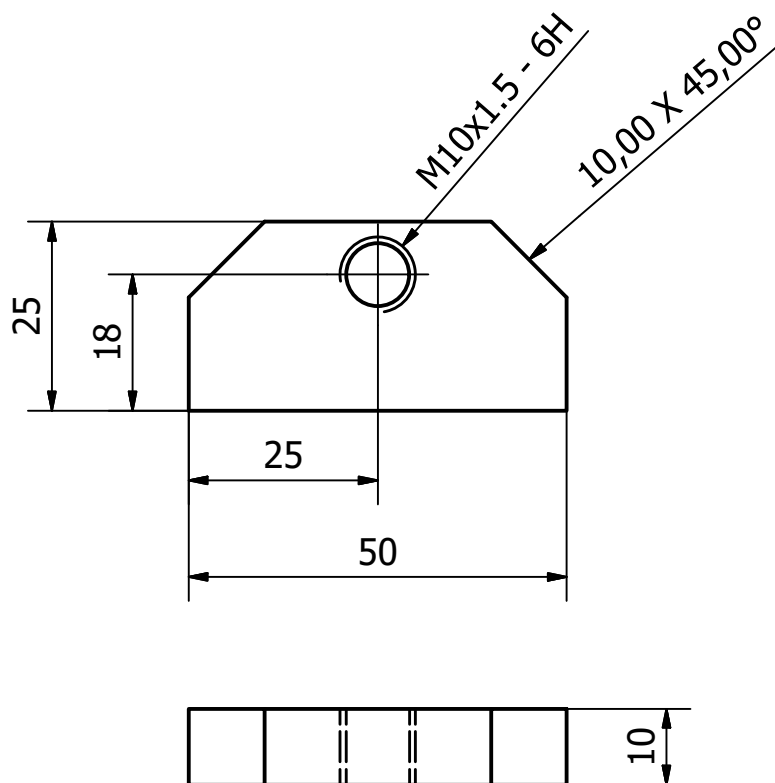

Conçu par L DUVOID	Vérifié par	Approuvé par	Date	Date 23/04/2020	
QUANTITE: x1 - MATIERE S235JR			BRIDAGE POUSSEUR		
			PLAT-BRIDAGE-POUSSEUR	Modification	Feuille 1 / 1

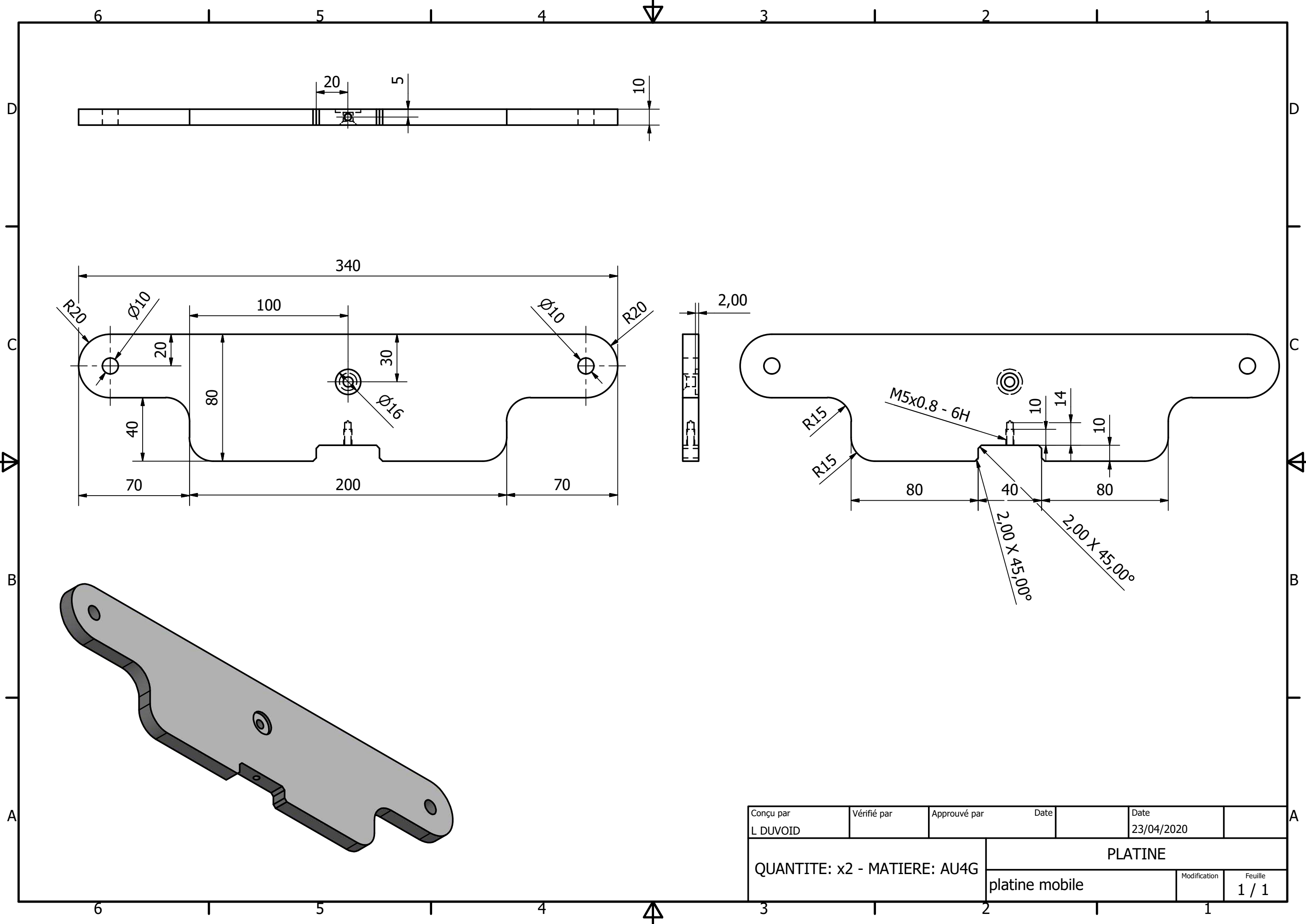

Conçu par L DUVOID	Vérifié par	Approuvé par	Date	Date 23/04/2020
QUANTITE: x2 - MATIERE: AU4G		PLATINE		
platine mobile		Modification	Feuille 1 / 1	

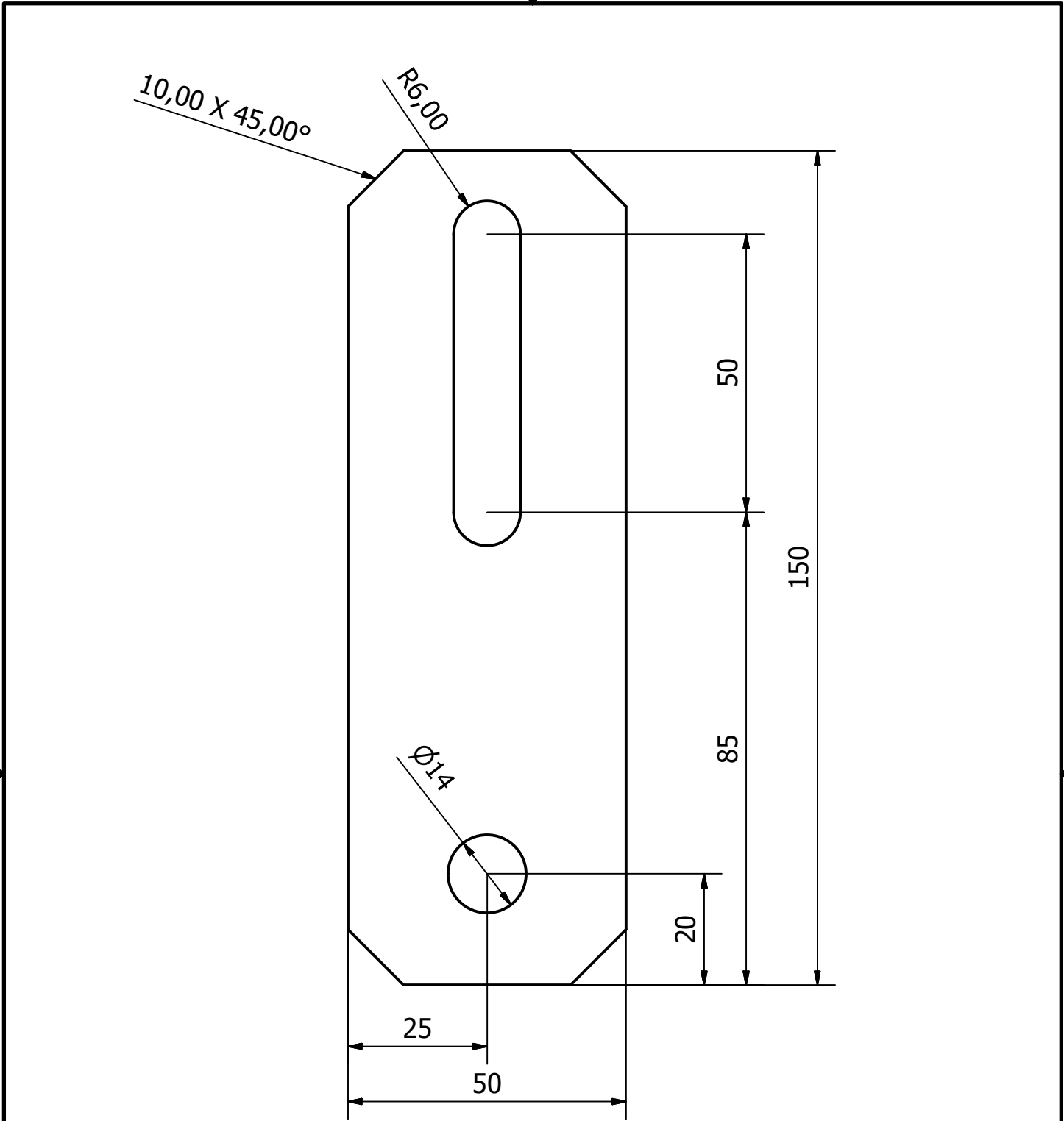

Conçu par L DUVOID	Vérfié par	Approuvé par	Date	Date 23/04/2020
QUANTITE: x1 - MATIERE s235 JR			PLAT POUSSEUR	
PLAT-POUSSEUR			Modification	Feuille 1 / 1

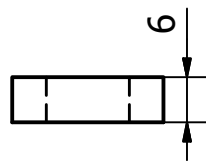
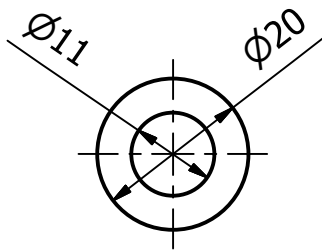

Conçu par L DUVOID	Vérifié par	Approuvé par	Date	Date 23/04/2020	
QUANTITE:x1 MATIERE: S235JR			RONDELLE BRIDAGE		
			RONDELLE	Modification	Feuille 1 / 1

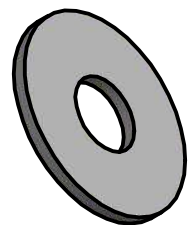
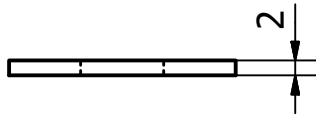
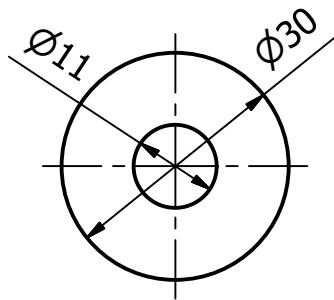

Conçu par L DUVOID	Vérifié par	Approuvé par	Date	Date 23/04/2020	
QUANTITE : x2 - MATIERE S235JR			RONDELLE		
			RONDELLE-BRIDAGE	Modification	Feuille 1 / 1

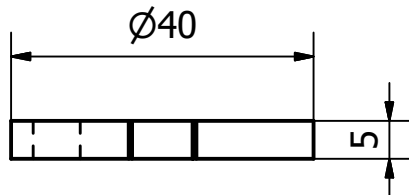
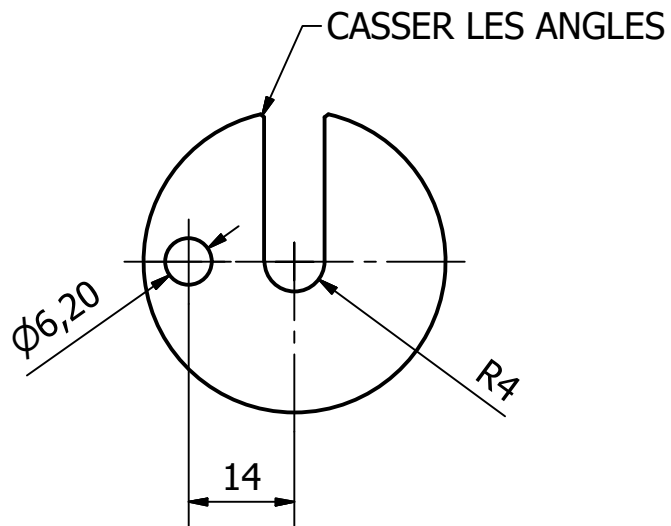

Conçu par L DUVOID	Vérifié par	Approuvé par	Date	Date 23/04/2020	
QUANTITE: x1 - MATIERE S235			VERROU		
verrou			Modification	Feuille 1 / 1	

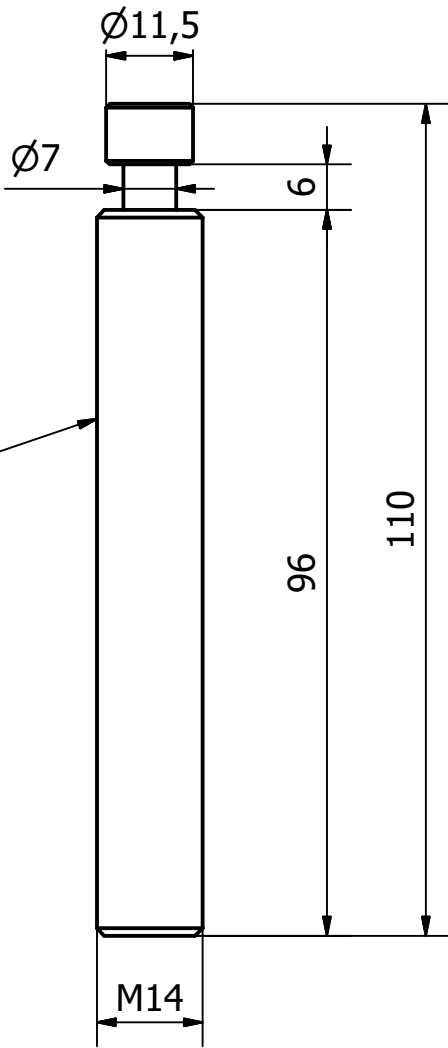

TIGE FILETEE M14

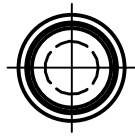

Conçu par L DUVOID	Vérifié par	Approuvé par	Date	Date 23/04/2020	
QUANTITE: x1 - MAT: TF M14			TIGE FILETEE M14		
			vis pression	Modification	Feuille 1 / 1



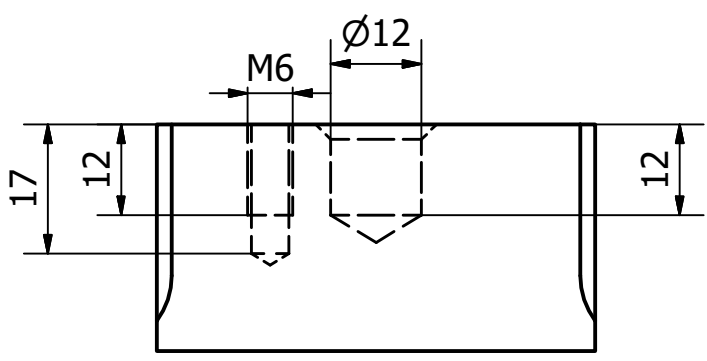
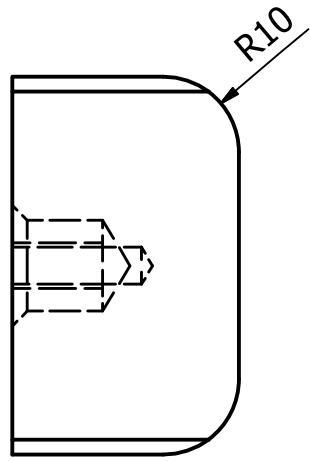
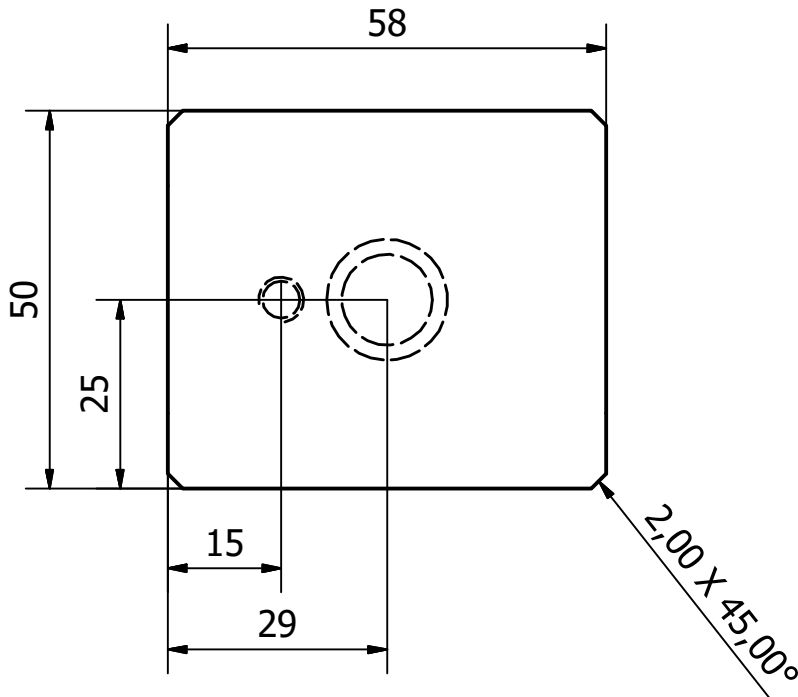

Conçu par L DUVOID	Vérifié par	Approuvé par	Date	Date 23/04/2020
QUANTITE: x1 - PLASTIQUE ABC			APPLIQUE	
APPLIQUE			Modification	Feuille 1 / 1

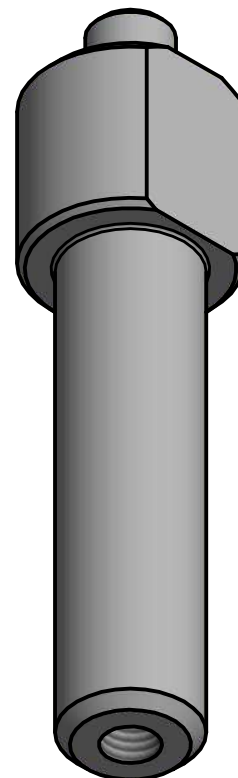
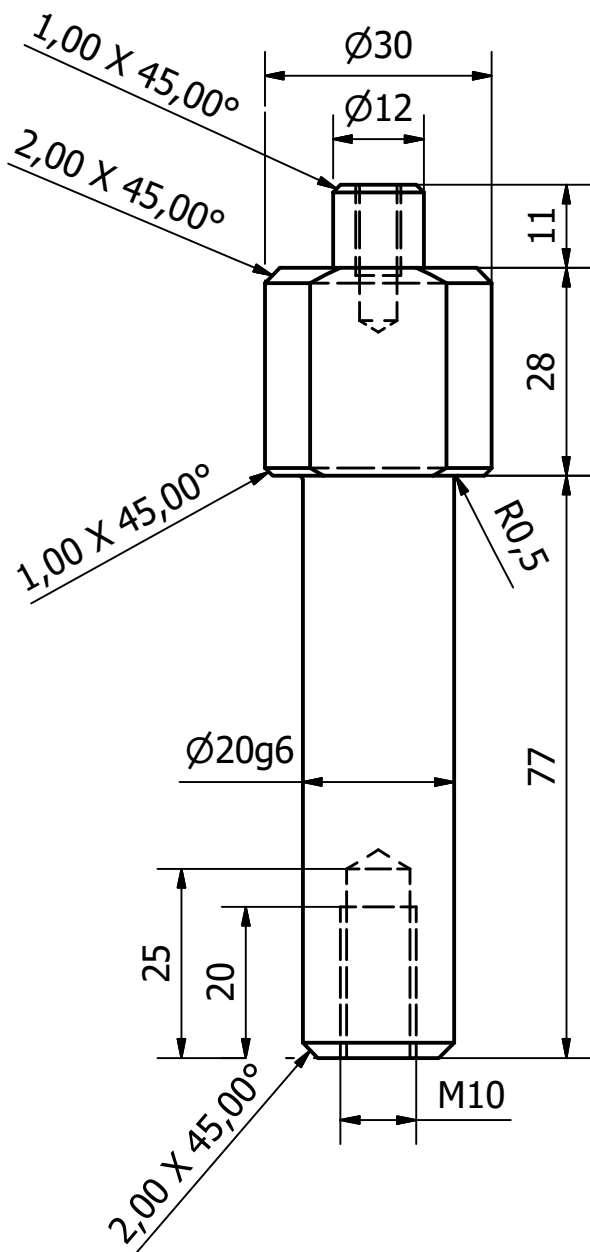
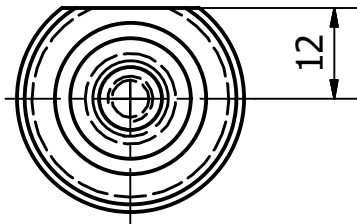

Conçu par L DUVOID	Vérfié par	Approuvé par	Date	Date 23/04/2020
QUANTITE: x1- MATIERE: STUB		AXE POUSSEUR		
		AXE POUSSEUR	Modification	Feuille 1 / 1

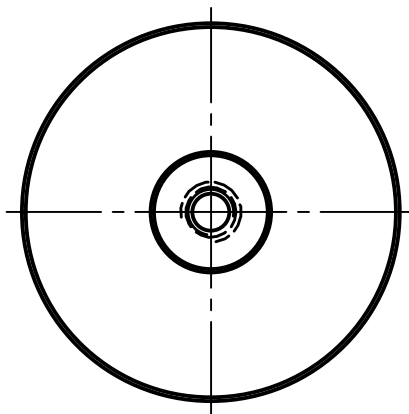
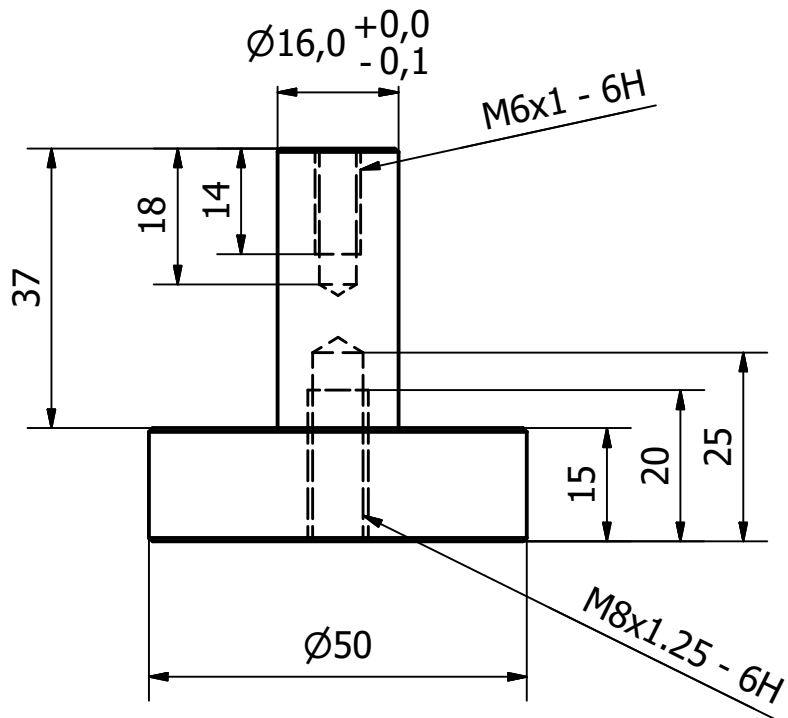

Conçu par L DUVOID	Vérifié par	Approuvé par	Date	Date 23/04/2020
QUANTITE:x1 - MATIERE S235		SUPPORT PLATINE MOBILE		
AXE		Modification	Feuille 1 / 1	

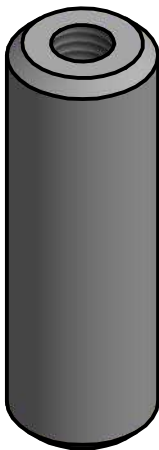
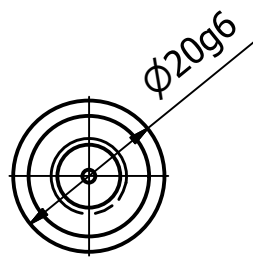
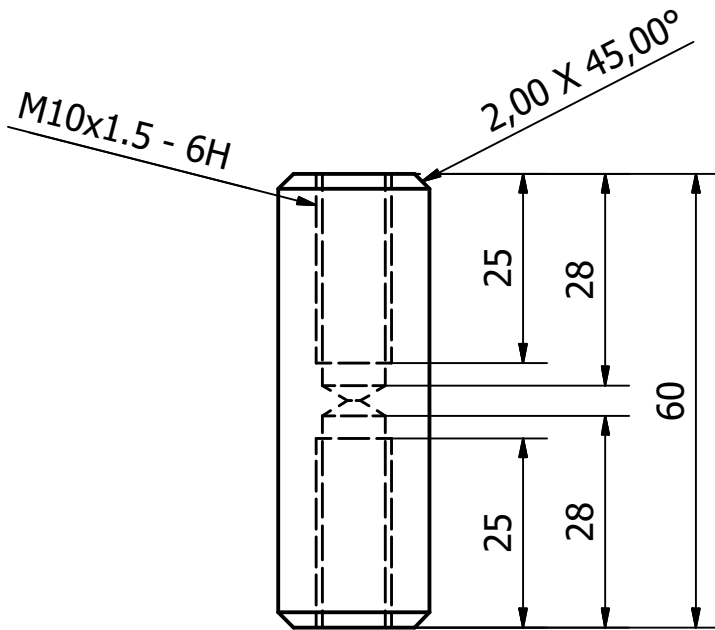

Conçu par L DUVOID	Vérifié par	Approuvé par	Date	Date 23/04/2020
QUANTITE: x2 - MATIERE STUB		AXE- PLATINE - MOBILE		
		AXE-PLATEAU	Modification	Feuille 1 / 1

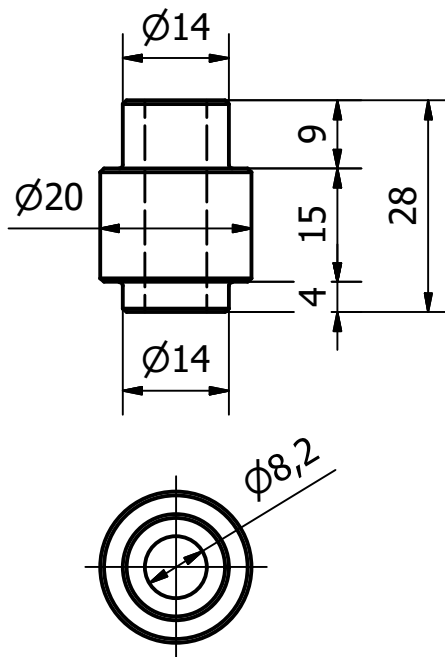

Conçu par L DUVOID	Vérifié par	Approuvé par	Date	Date 23/04/2020
QUANTITE: x1 - MATIERE STUB		AXE-PLATEAU-POUSSEUR		
		Axe-plateau-pousseur	Modification	Feuille 1 / 1

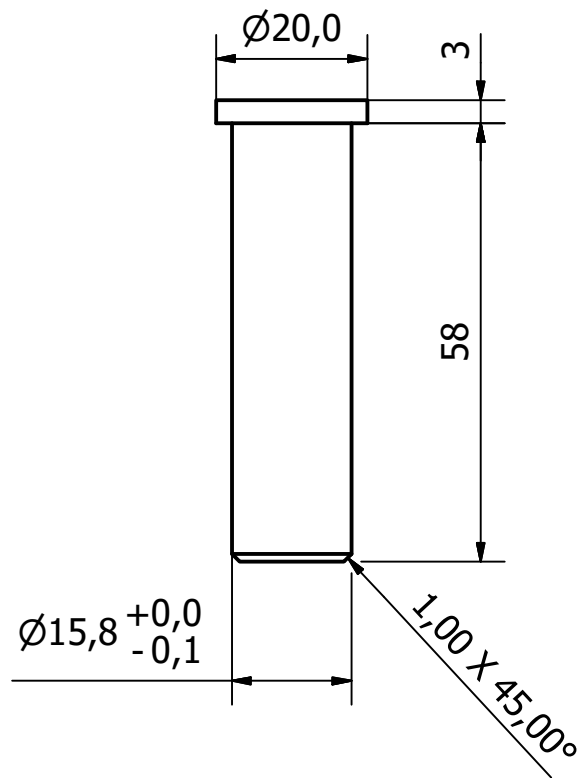
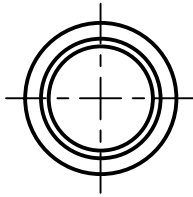

Conçu par L DUVOID	Vérifié par	Approuvé par	Date	Date 23/04/2020	
QUANTITE: x1 - MATIERE S235			AXE BLOCAGE		
			BLOCAGE	Modification	Feuille 1 / 1

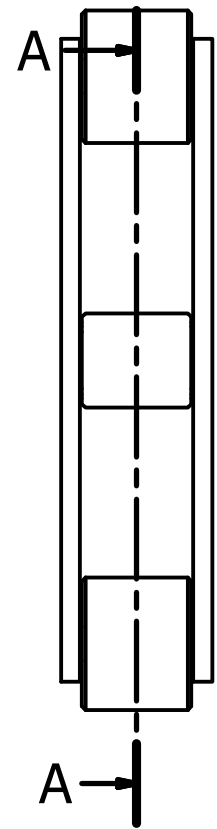
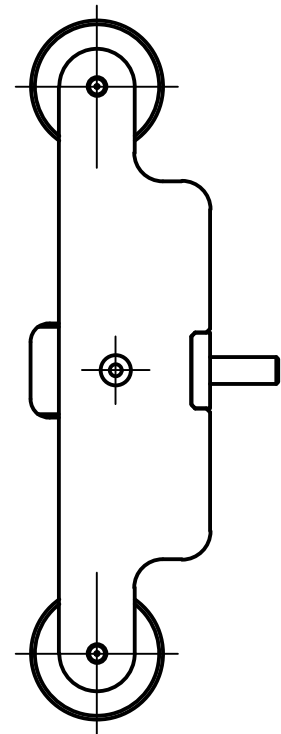

A-A (1 : 4)

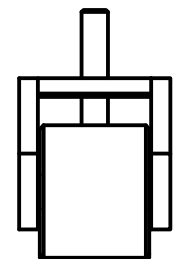
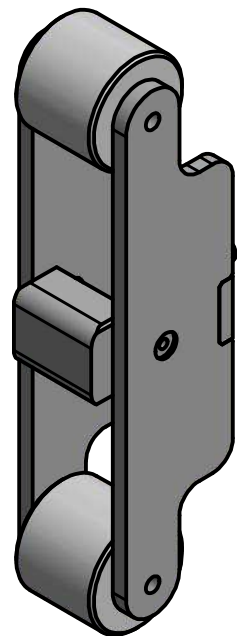
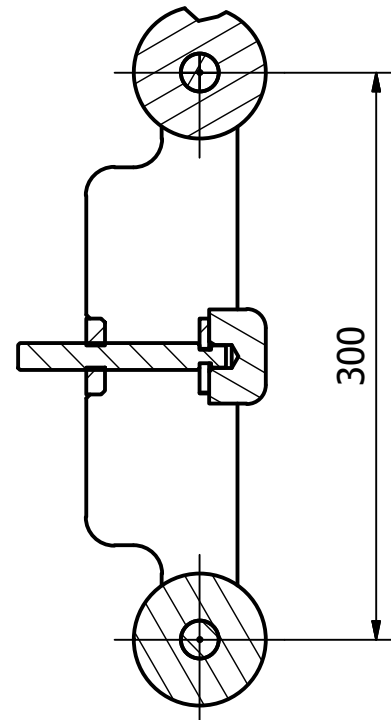

LISTE DE PIECES			
ARTICLE	QTE	NUMERO DE PIECE	DESCRIPTION
1	2	platine mobile	
2	1	liaison	
3	2	AXE-PLATEAU	
4	2	GALET	
5	1	APPLIQUE	
6	1	verrou	
7	1	vis pression	

Conçu par L DUVOID	Vérifié par	Approuvé par	Date	Date 23/04/2020
QUANTITE: X1		ENSEMBLE PLATINE MOBILE		
		Ens-platine-mobile	Modification	Feuille 1 / 1

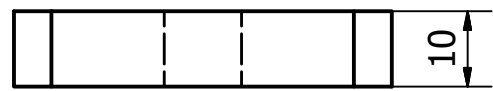
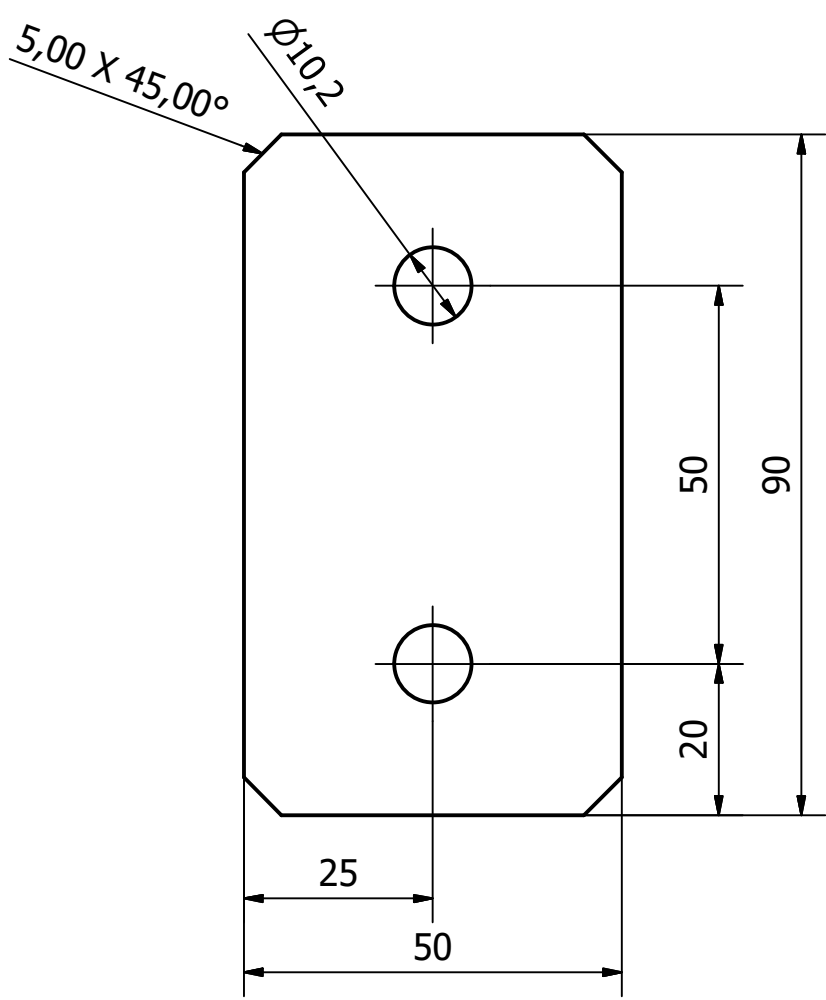

Conçu par L DUVOID	Vérifié par	Approuvé par	Date	Date 23/04/2020
QUANTITE: x1 - MATIERE S235JR		FIXATION		
		Fixation	Modification	Feuille 1 / 1

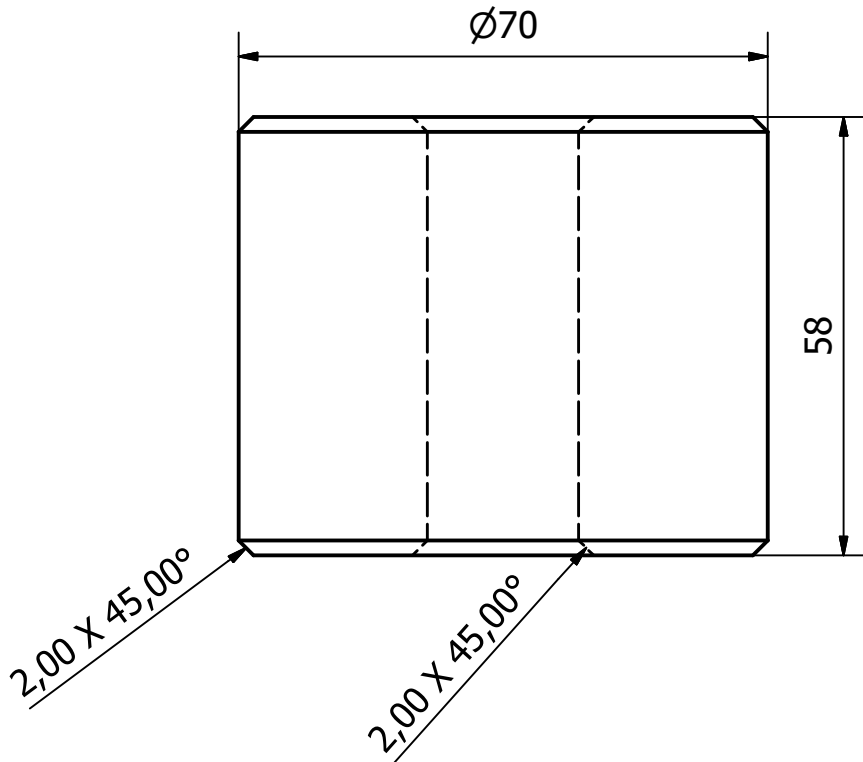
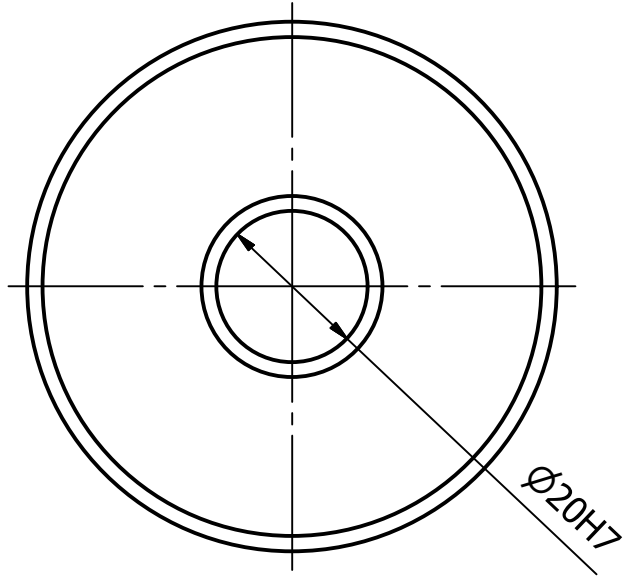

Conçu par L DUVOID	Vérifié par	Approuvé par	Date	Date 23/04/2020
QUANTITE: x2 - PLATISQUE ABC		GALET		
		GALET	Modification	Feuille 1 / 1

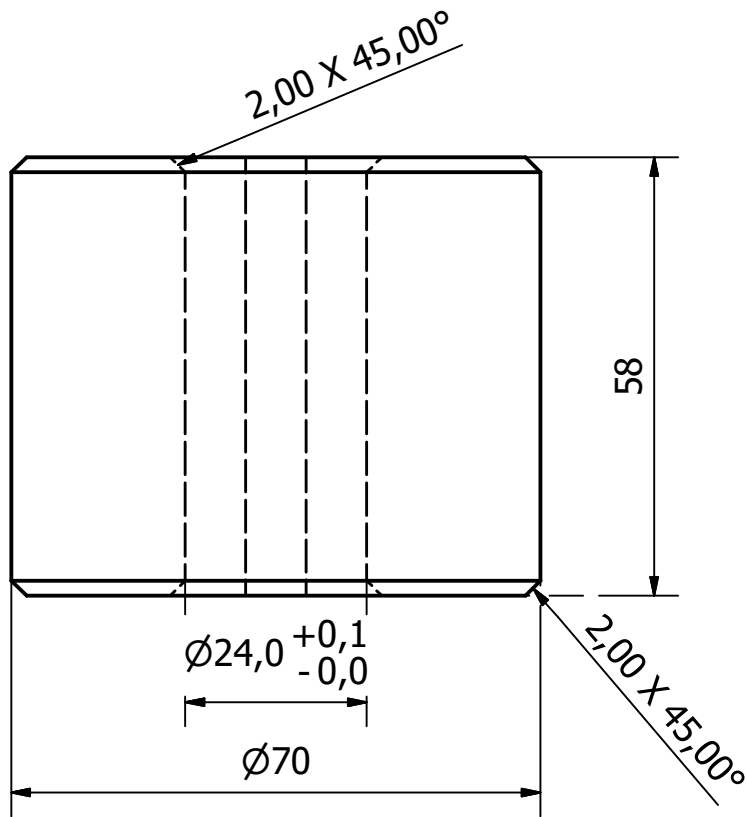
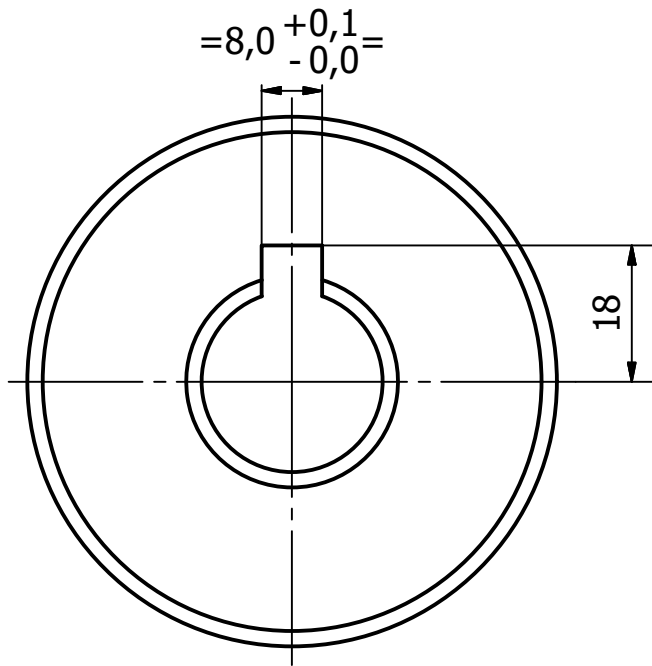

Conçu par L DUVOID	Vérifié par	Approuvé par	Date	Date 23/04/2020
QUANTITE: x1 - PLASTIQUE ABC		GALET MOTEUR		
		GALET-MOTEUR	Modification	Feuille 1 / 1