

1	Reperage des cotes	TOLERANCES GENERALES
	△ Cote critique	SUIVANT : ISO2768-mH
	○ Cote majeur	
	1 MINI MAXI 2 MAXI 3 MINI	

- 2 Masse = 65.36 g
- 3 Surface = 21892.04 mm<sup>2</sup>
- 4 Volume = 65361.96 mm<sup>3</sup>
- 5 Casser toutes les arrêtes vives  
Chanfrein : Ch1x45°

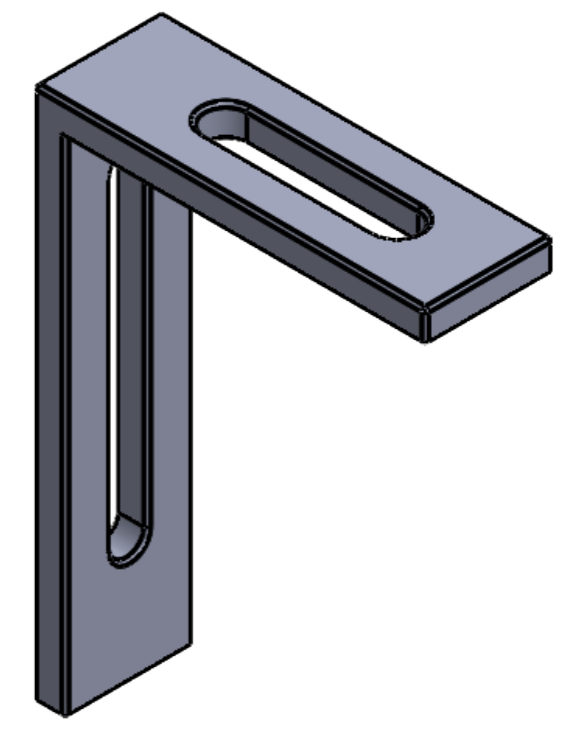
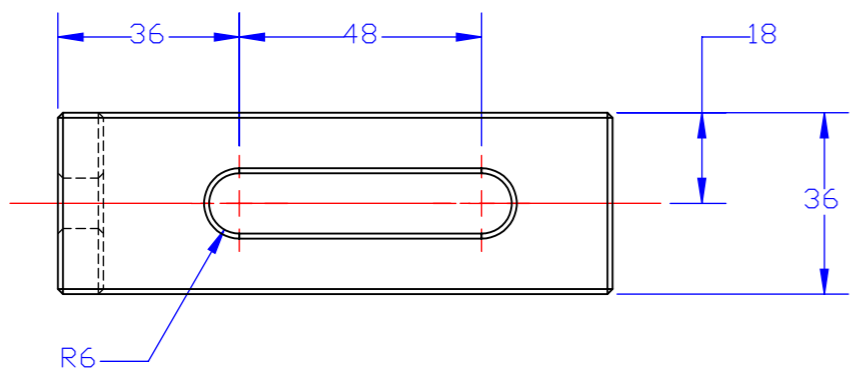
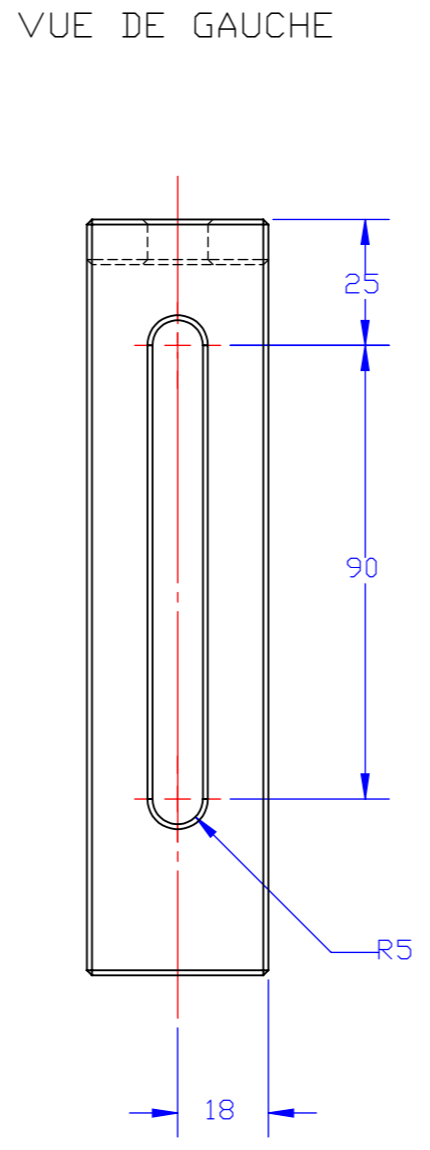
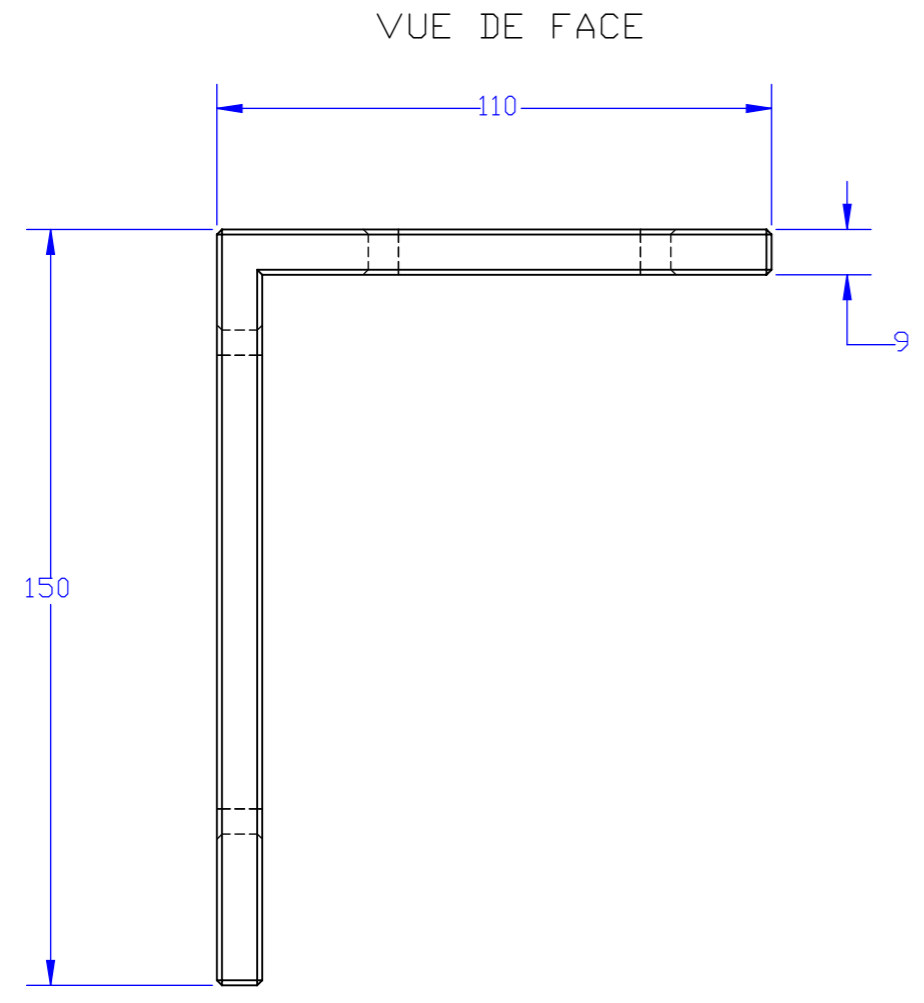

VUE ISOMETRIQUE

DESSINATEUR : T. PISSOT		ETAT DE SURFACE : $\sqrt{Ra}$ 3,2		
DATE : 13NOV2019				
DIMENSION mm	TOLERANCE ANGLE 1			
DESIGNATION : EQUERRE			MATIERE : ACIER	
ECHELLE : 2:3	FORMAT : A3	N° PLAN : DRW-19-0001	FEUILLE 1 SUR 1	INDICE A

INDICE	DESCRIPTION	DATE
A	CREATION	13NOV2019