

Ecrou spécial percé

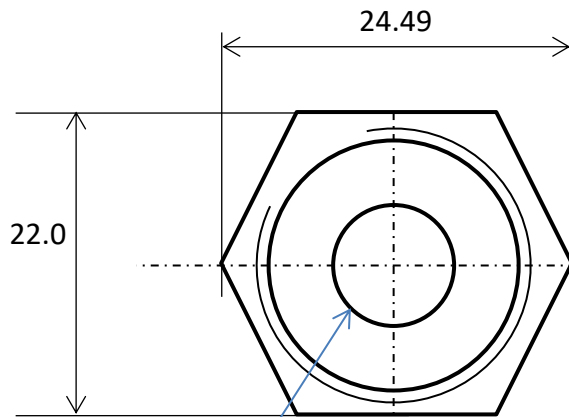

*Perçage
débouchant
Diamètre
12.0^{-0.02}_{+0.05}*

*Filetage G1/2 BSP
Parallel – G14*

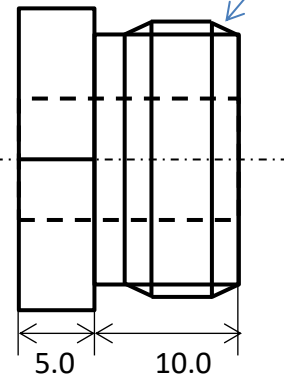

Concentricité filetage / perçage : 0.05 mm

Ecrou piston A52
Tolérances générales : +/- 0.1 mm
Matière : inox 316L