

Part 1

Plaque aluminium
Epaisseur 5 mm \pm 0,5
Nuance sans importance

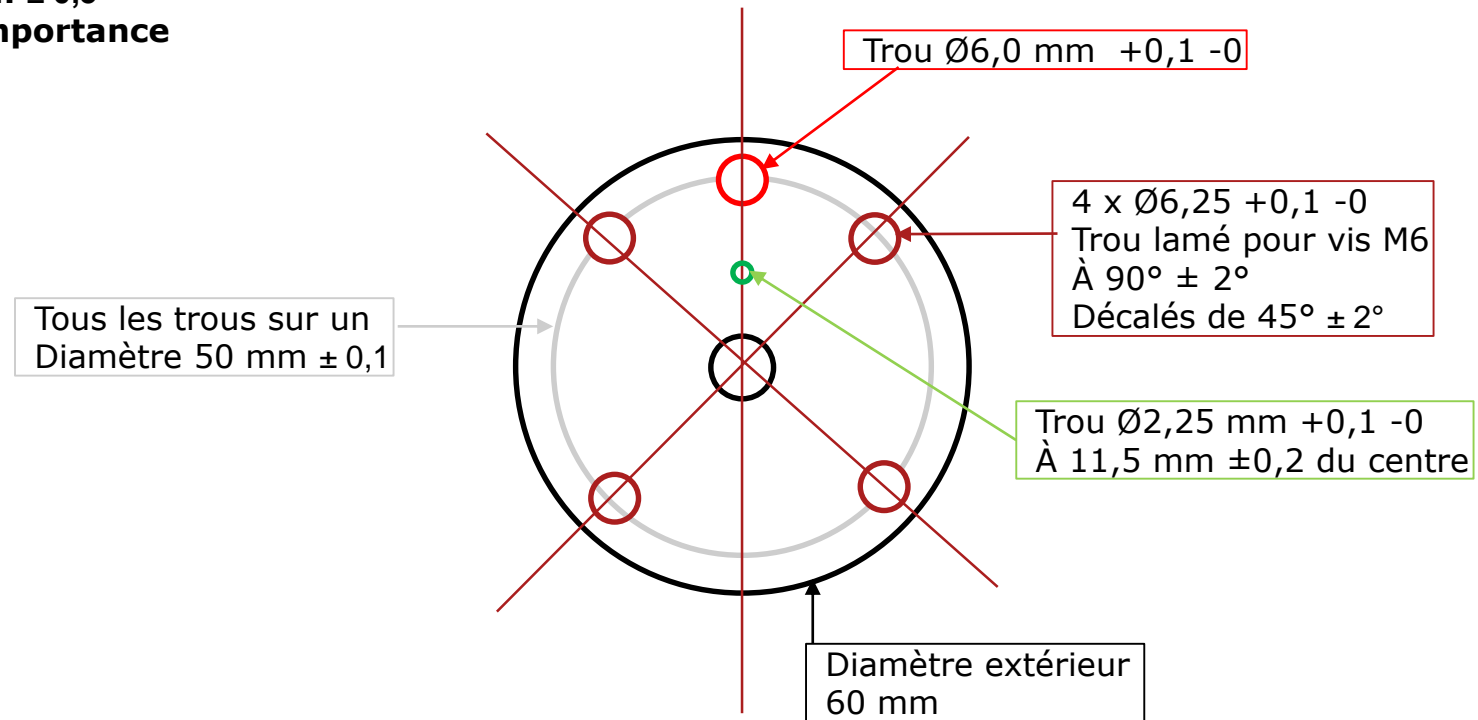

Part 2

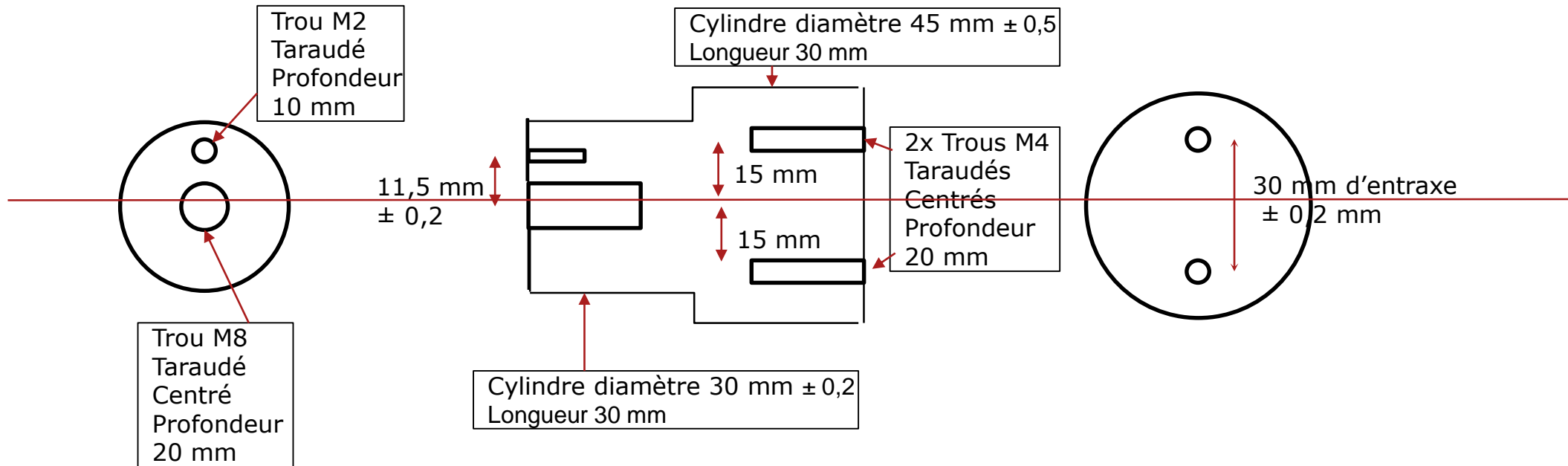

Matière Aluminium
Nuance sans importance