

6 5 4 3 2 1

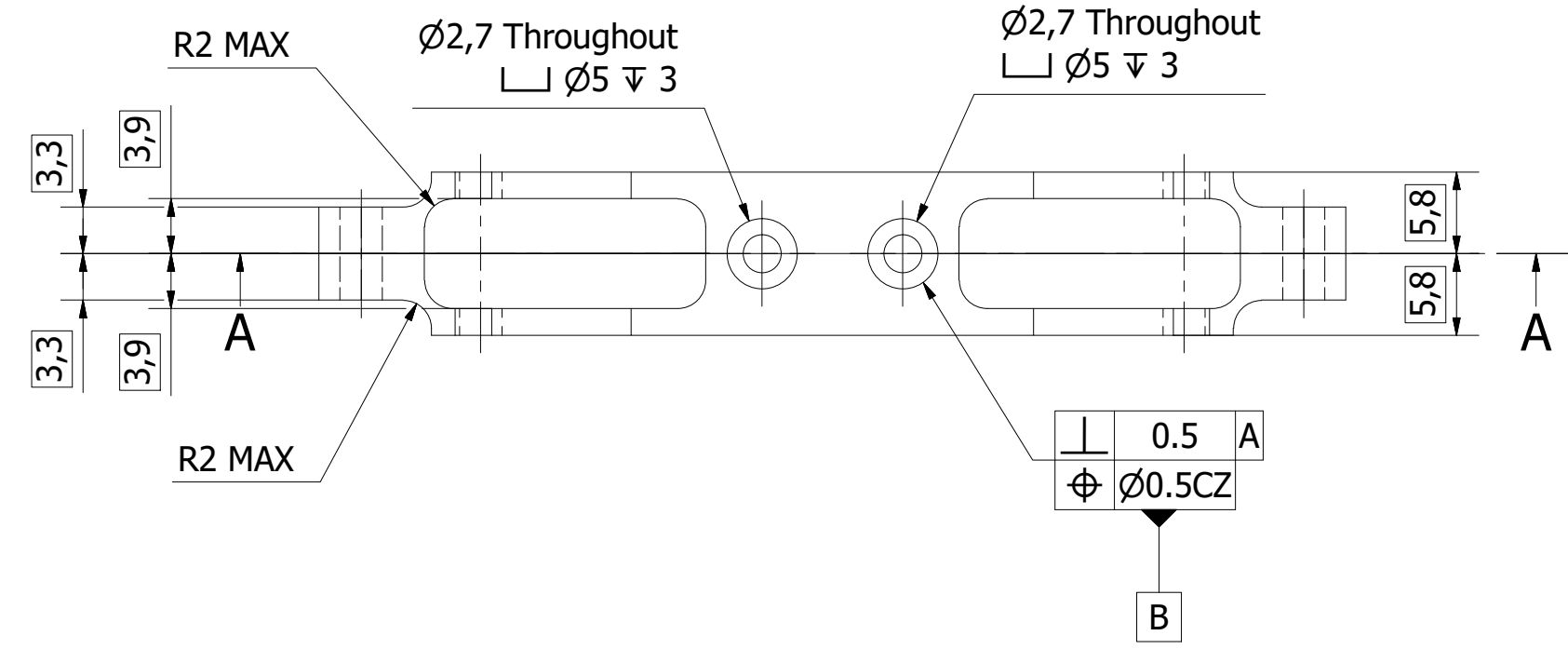
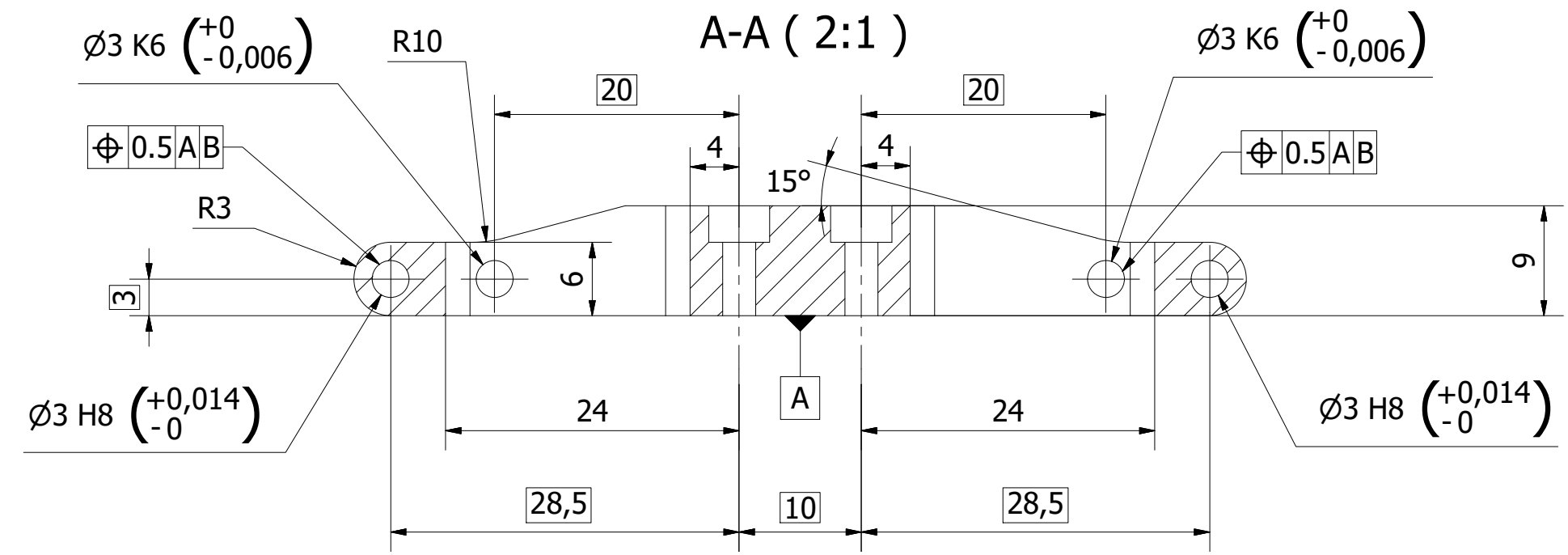

Material :
Aluminum | EN 3.3535 / AW-5754 | AlMg3 - H14

Treatment :
Type: -
Thickness: -
Note:

Surface :
Rugosity: Ra 16 μm
Deburring Sharp Edges: Yes

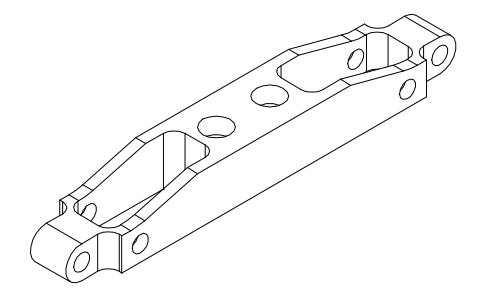

Units : mm
General Tolerances : ISO 2768 mK + ISO 8015

6 5 4 3 2 1