

Vue de dessous  
Echelle : 3:2

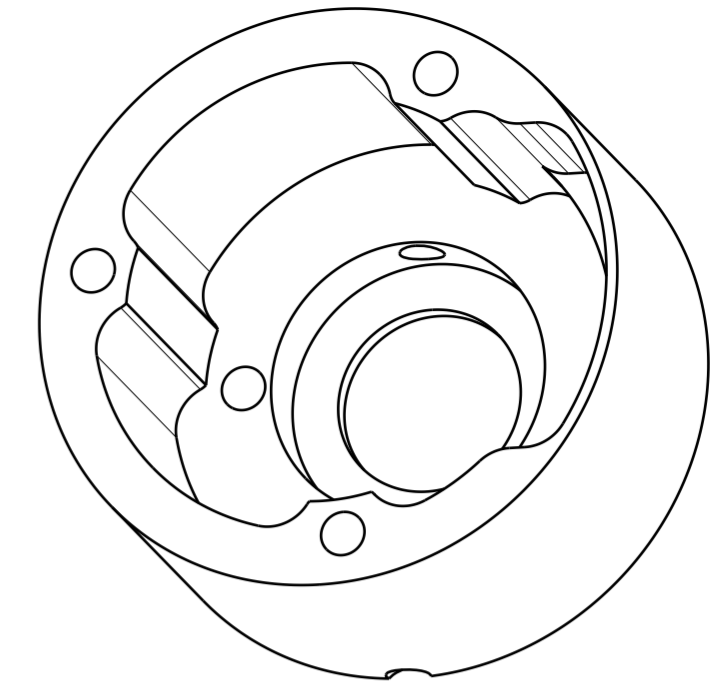

Vue isométrique  
Echelle : 3:2

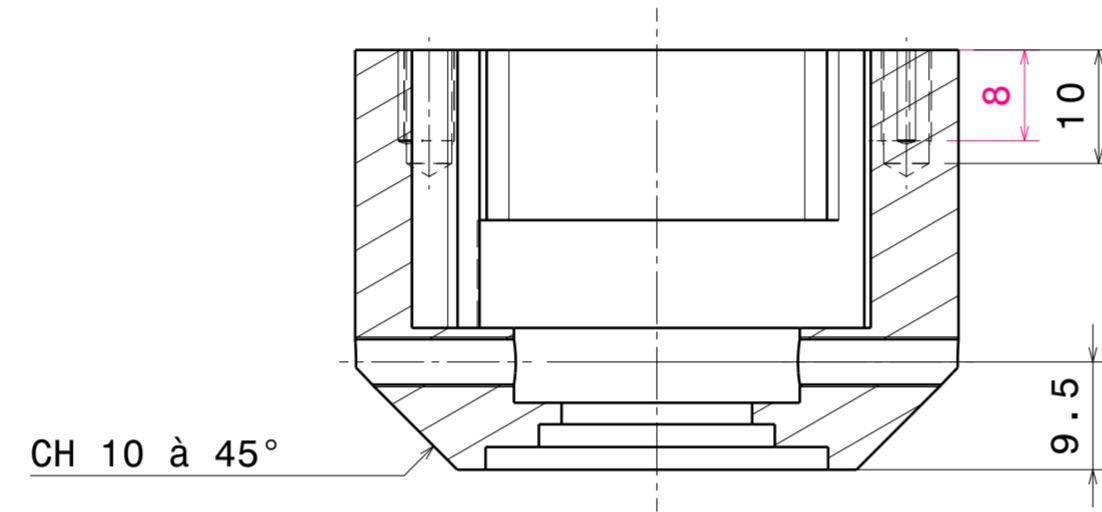

Coupe B-B  
Echelle : 3:2

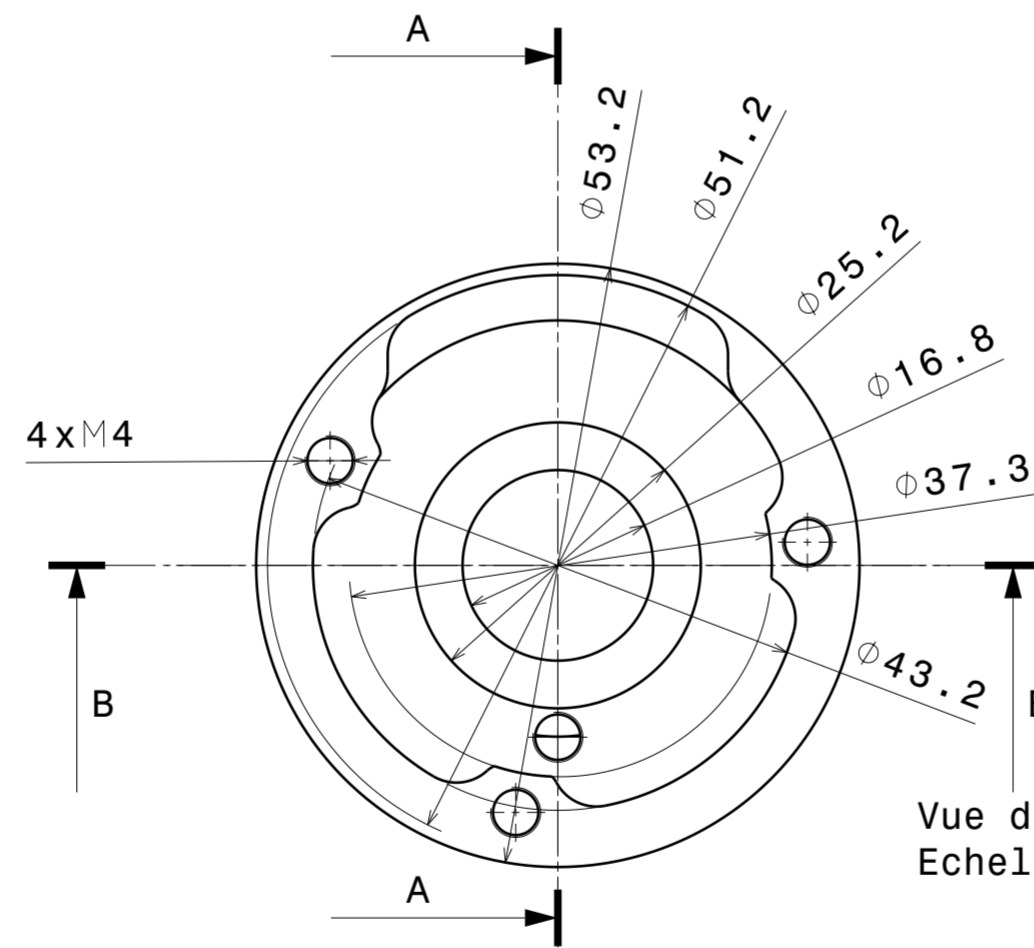

Vue de face  
Echelle : 3:2

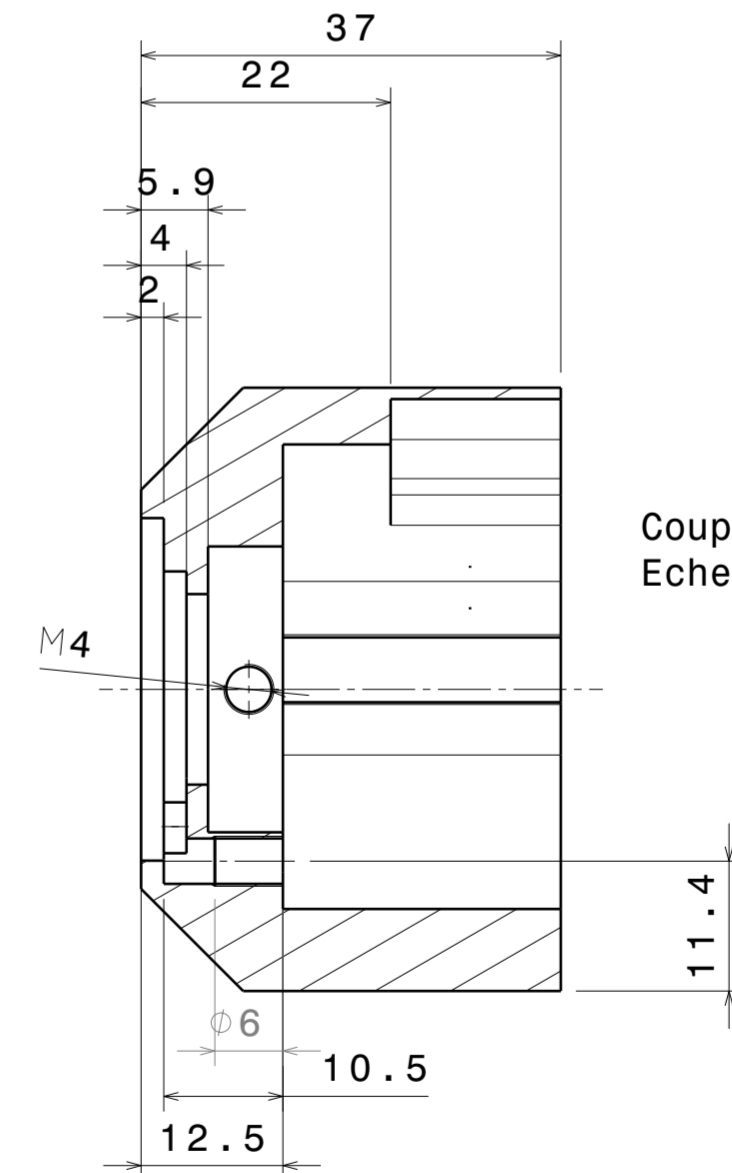

Coupe A-A  
Echelle : 3:2

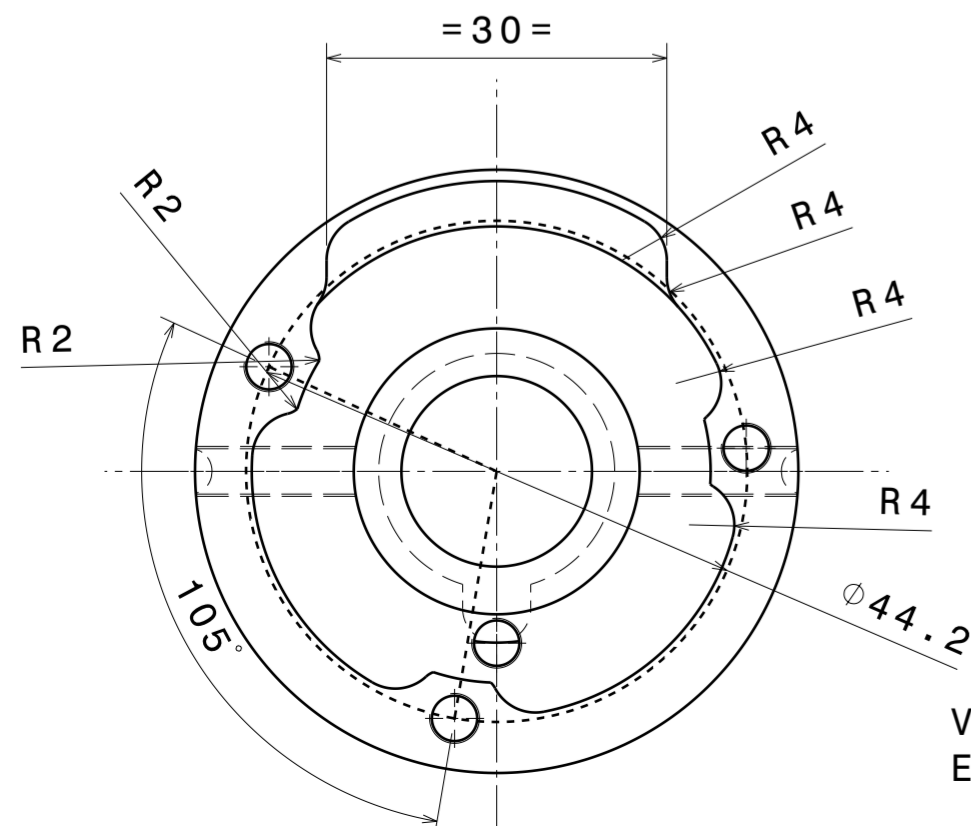

Vue de face congés  
Echelle : 3:2

Toutes les dimensions sont en mm							Titre			TETE CAPTEUR																																			
Tolérances générales							Auteur			R. JACQUINOT			Modifications			Création			Date			27/11/2018																							
				R. JACQUINOT			R. JACQUINOT			Modification						04/12/2018			Numéro de plan			CSCAN-USI-02																							
Longueurs				<=6			+/- 0.1			>6 à 30			+/- 0.2			>30 à 120			+/- 0.3			>120			+/- 0.5			Taille			A2			Materiau			POM C NOIR			Rev :			1		
Angles (selon la longueur du petit coté)				<= 10			+/- 1°			>10 à 50			+/- 30'			>50 à 120			+/- 20'			>120			+/- 10'			Echelle			3:2			Masse (kg)			XXX			Feuille			1/1		