

COUPE C-C  
ECHELLE 3 : 1

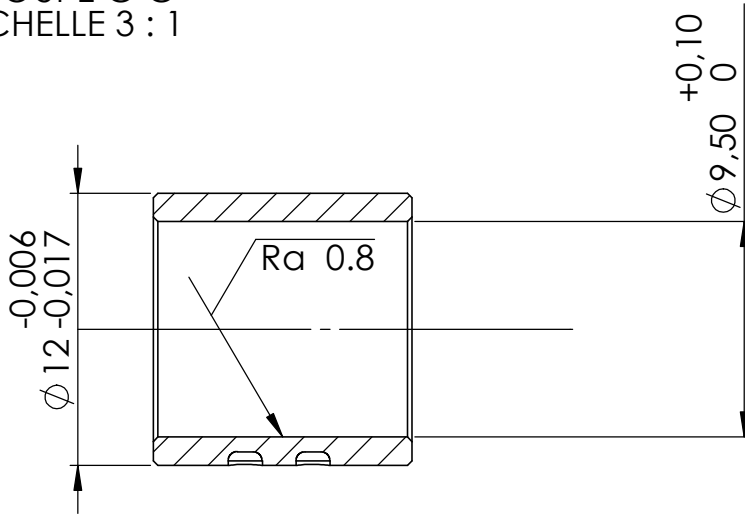

2 X 0.2 A 45°

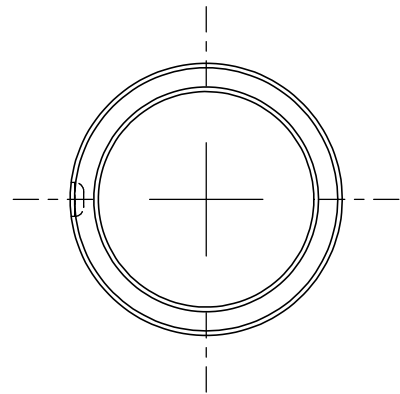
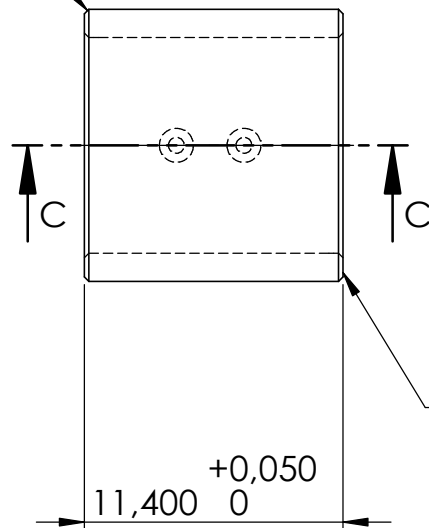

2 X 0.2 A 45°

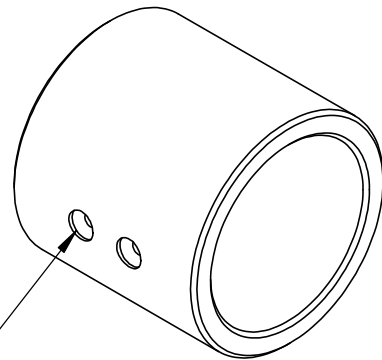

MARQUAGE DE 2 POINTS  
SUR LE COTE

SAUF INDICATION CONTRAIRE:  
LES COTES SONT EN MILLIMETRES  
ETAT DE SURFACE: Ra 1,6  
TOLERANCES:  
LINEAIRES: + - 0,1  
ANGULAIRES:

FINITION:

CASSER LES  
ANGLES VIFS

NE PAS CHANGER L'ECHELLE

REVISION

NOM	SIGNATURE	DATE			
AUTEUR	De. P.	06/11/18			
VERIF.					
APPR.					
FAB.					
QUAL.					
			MATERIAU: Aluminium T6 6082		
			MASSE:		

TITRE:

BAGUE 1104-39

No. DE PLAN

ST-008-1189 A

A4

ECHELLE: 3:1

FEUILLE 1 SUR 1