

$\phi 12$   
-0,01  
-0,02

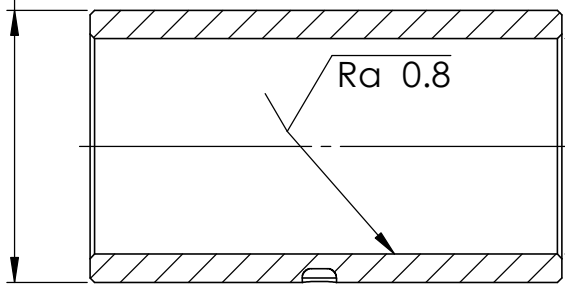

$\phi 9,50$   
+0,10  
0

COUPE C-C  
ECHELLE 3 : 1

2 X 0.2 A 45°

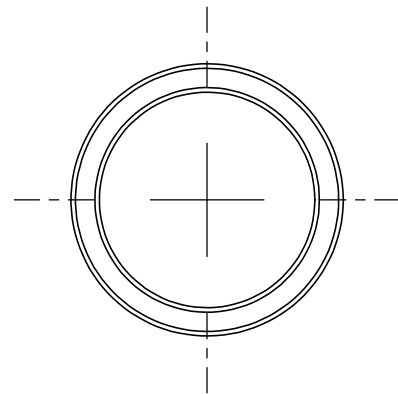
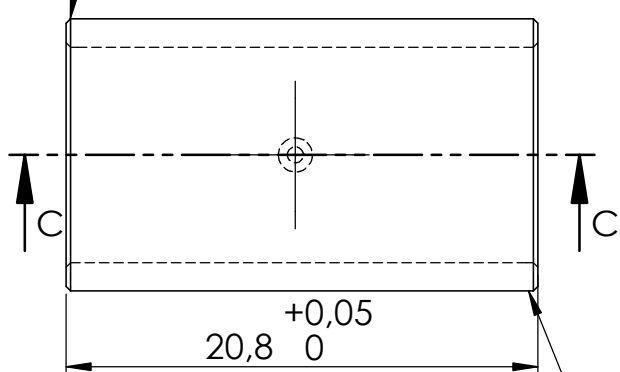

2 X 0.2 A 45°

MARQUAGE DE 1 POINTS  
SUR LE COTE

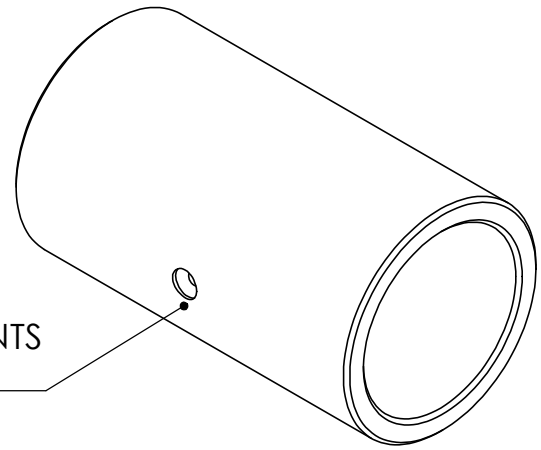

SAUF INDICATION CONTRAIRE:  
LES COTES SONT EN MILLIMETRES  
ETAT DE SURFACE: Ra 1,6  
TOLERANCES:  
LINEAIRES: + - 0,1  
ANGULAIRES:

FINITION:

CASSER LES  
ANGLES VIFS

NE PAS CHANGER L'ECHELLE

REVISION

NOM	SIGNATURE	DATE		
AUTEUR	De. P.	06/11/18		
VERIF.				
APPR.				
FAB.				
QUAL.				
MATERIAU:				
Aluminium T6 6082				
MASSE:				

TITRE:		No. DE PLAN		
BAGUE 1104-22		ST-007-1189 A		A4
ECHELLE: 3:1		FEUILLE 1 SUR 1		