

COUPE C-C  
ECHELLE 3 : 1

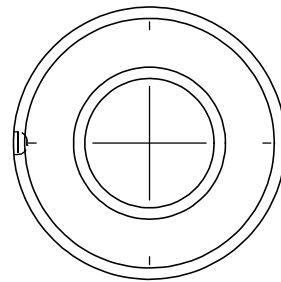

MARQUAGE DE 3  
POINTS  
SUR LE COTE

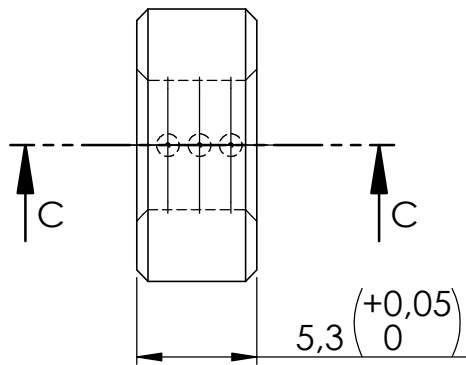
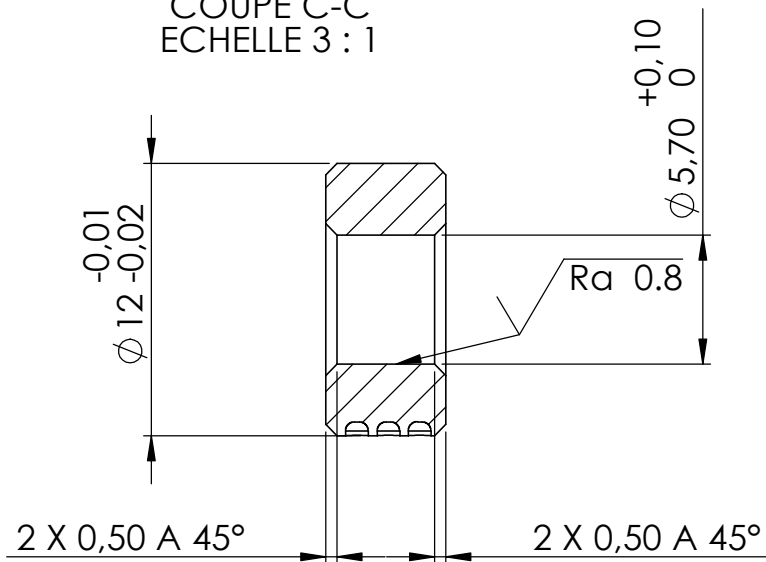
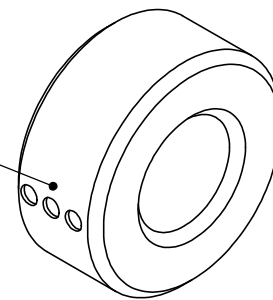

SAUF INDICATION CONTRAIRE:  
LES COTES SONT EN MILLIMETRES  
ETAT DE SURFACE: Ra 1,6  
TOLERANCES:  
LINEAIRES: + - 0,1  
ANGULAIRES:

FINITION:

CASSER LES  
ANGLES VIFS

NE PAS CHANGER L'ECHELLE

REVISION

NOM	SIGNATURE	DATE	MATERIAU:
AUTEUR De. P.		06/11/18	Aluminium T6 6082
VERIF.			
APPR.			
FAB.			
QUAL.			
			MASSE:

TITRE:

BAGUE 368-49

No. DE PLAN

ST-017-1189-A

A4

ECHELLE: 3:1

FEUILLE 1 SUR 1