

COUPE C-C
ECHELLE 3 : 1

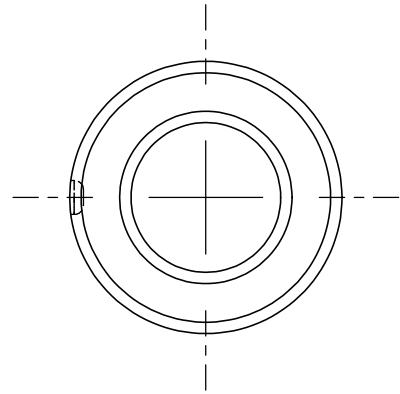

MARQUAGE DE 1 POINTS
SUR LE COTE

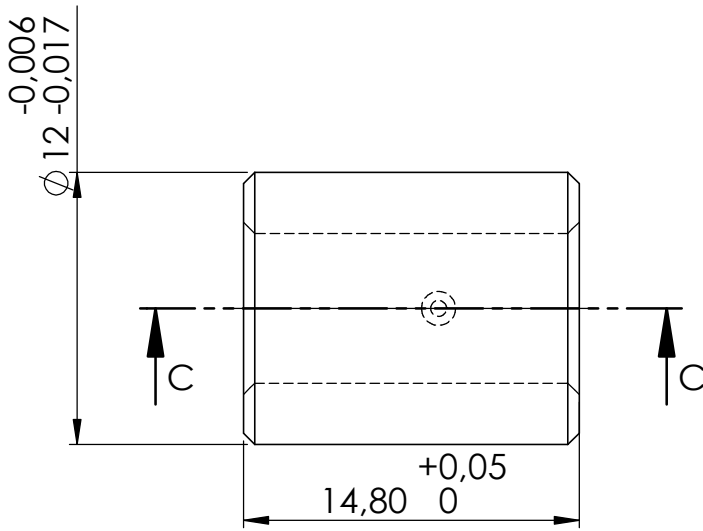
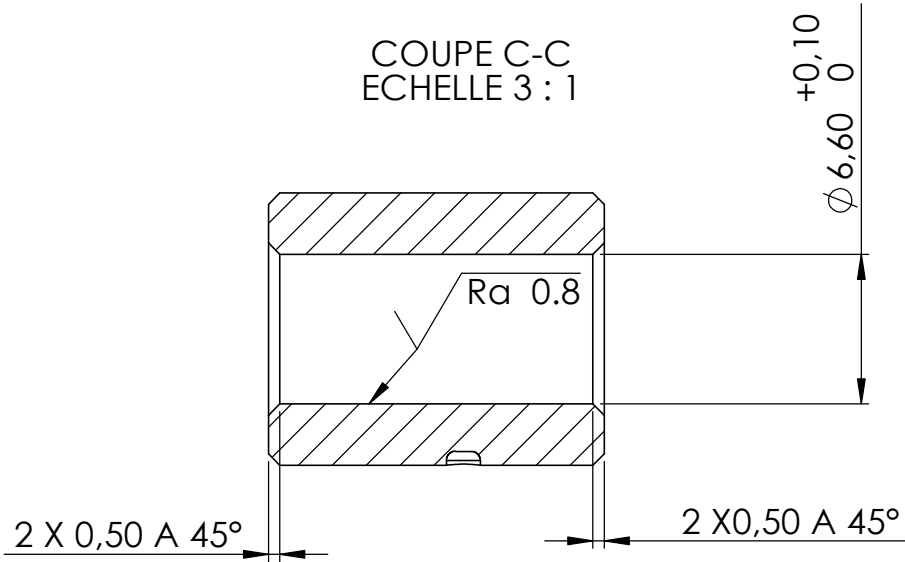
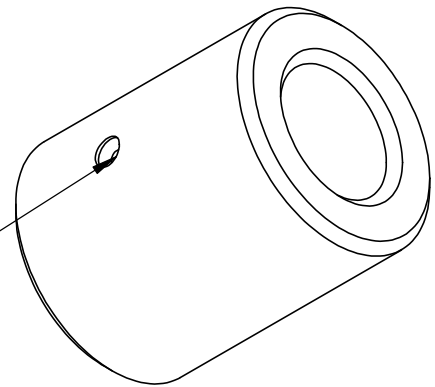

SAUF INDICATION CONTRAIRE:
LES COTES SONT EN MILLIMETRES
ETAT DE SURFACE: Ra 1,6
TOLERANCES:
LINEAIRES: + - 0,1
ANGULAIRES:

FINITION:

CASSER LES
ANGLES VIFS

NE PAS CHANGER L'ECHELLE

REVISION

NOM	SIGNATURE	DATE	MATERIAU:
AUTEUR De. P.		06/11/18	Aluminium T6 6082
VERIF.			
APPR.			
FAB.			
QUAL.			
			MASSE:

TITRE:

BAGUE 552-22

No. DE PLAN

ST-011-1189-A

A4

ECHELLE: 3:1

FEUILLE 1 SUR 1