

COUPE C-C
ECHELLE 3 : 1

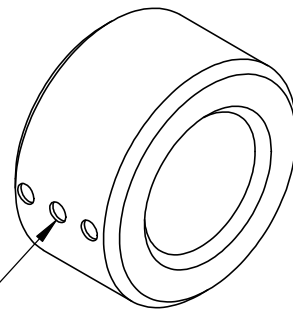
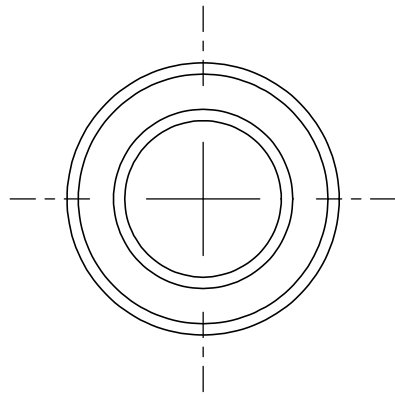
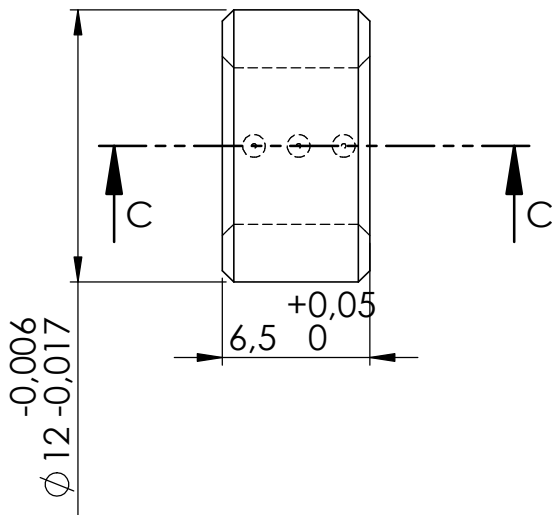
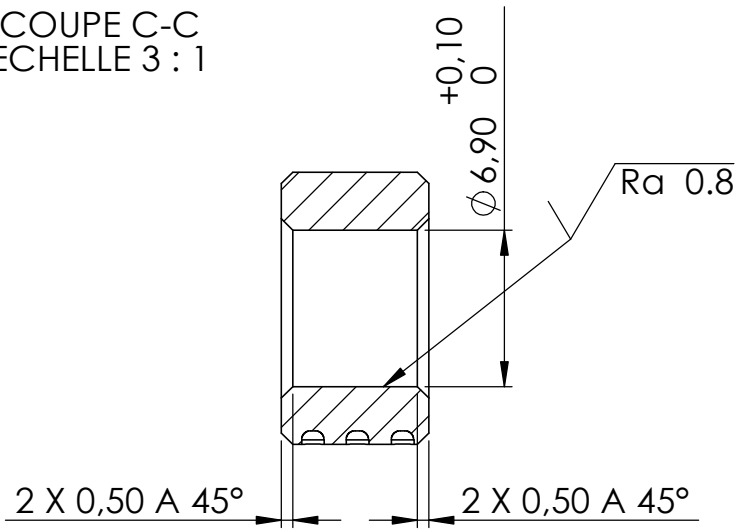

MARQUAGE DE 3 POINTS
SUR LE COTE

SAUF INDICATION CONTRAIRE:
LES COTES SONT EN MILLIMETRES
ETAT DE SURFACE: Ra 1,6
TOLERANCES:
LINEAIRES: + - 0,1
ANGULAIRES:

FINITION:

CASSER LES
ANGLES VIFS

NE PAS CHANGER L'ECHELLE

REVISION

	NOM	SIGNATURE	DATE		
AUTEUR	De. P.		06/11/18		
VERIF.					
APPR.					
FAB.					
QUAL.				MATERIAU:	
				Aluminium T6 6082	
				MASSE:	

TITRE:

BAGUE 552-48

No. DE PLAN

ST-013-1189-A

A4

ECHELLE: 3:1

FEUILLE 1 SUR 1