

CONFIDENTIAL AND TRADE SECRET. DO NOT DISCLOSE, USE, OR REPRODUCE WITHOUT WRITTEN APPROVAL FROM SCHLUMBERGER.

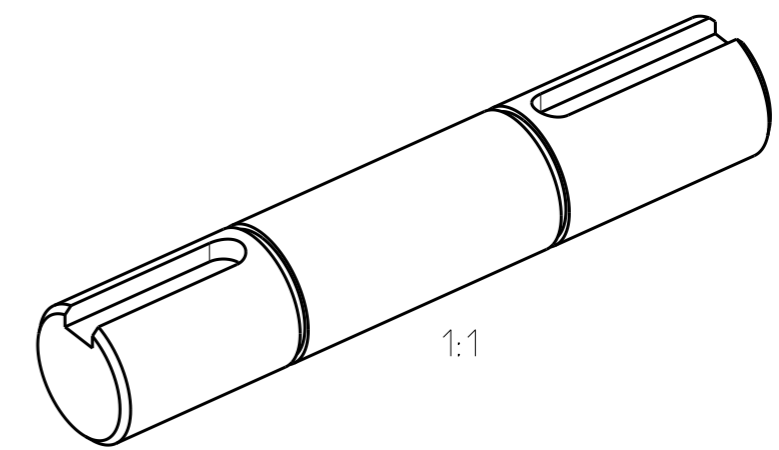
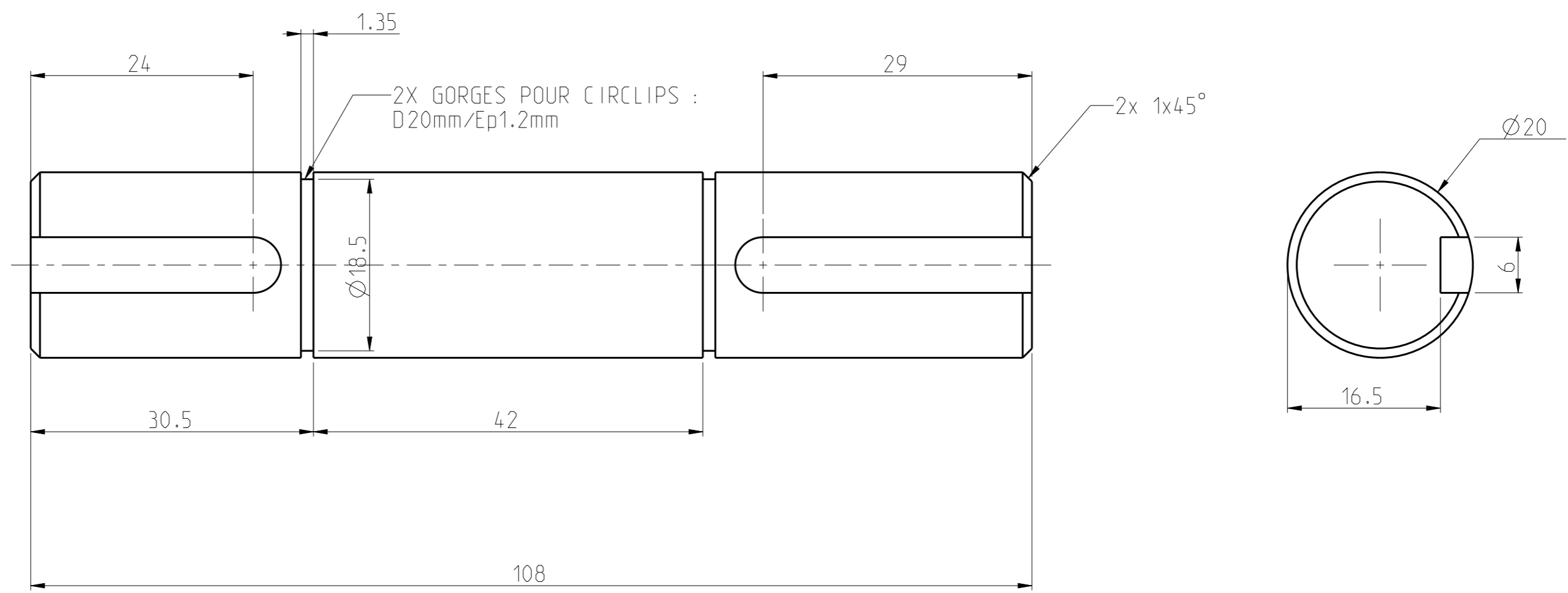

FINISH: NONE TREATMENT: NONE		ACIER C35E		REVISED	27-JUN-2018		
FINISH OR TREATMENT		MATERIAL		CHECKER	27-JUN-2018		
				ENGINEER	27-JUN-2018		
				DESIGNER	27-JUN-2018		
UNLESS OTHERWISE SPECIFIED				ARBRE 1 - D20mm			
SURFACE FINISHES MACH: Ra 3.2 CAST: Ra 6.3 INTERPRET PER ISO 1302:2002		TOLERANCES LINEAR/GEOMETRIC TOLERANCES ISO 2768-mk ANGULAR TOLERANCES ISO 2768-c INTERPRET DIMENSIONS PER ISO 1101:2004					
INSIDE CORNER R 0.4 ± 0.1		REMOVE BURRS. BREAK EDGES R OR CH 0.2±0.1 DIMENSIONS INCLUDE APPLIED FINISHES				FORMAT A3	SCALE 2:1
				UNITS mm	AXE-1		REVISION AA
						PAGE 1/1	