

PERCAGES TRAVERSANTS
COTES IDENTIQUES AU DETAIL A

DÉTAIL A ECHELLE 1:5

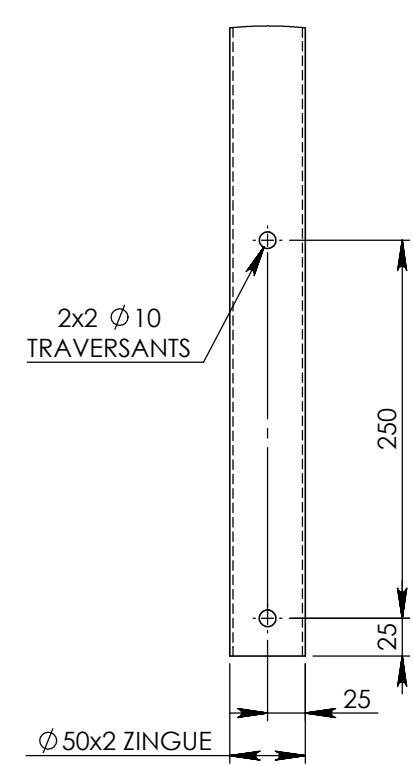

<small>Tolérance Mécano-soudure: de 0m à 1m = ±1mm, de 1m inclus à 3m = ±1.5mm, à partir de 3m = ±2.5mm / Tolerance for welded frame: from 0m to 1m = ±1mm, from 1m included to 3m = ±1.5mm, upper 3m included = ±2.5mm Tolérance générale d'usinage: ISO 2768-mK - Ebavurer les angles vifs - Ne pas peindre les surfaces usinées / General tolerance for machined surface: ISO2768-mK - Deburr the sharp angles - Do not paint the machined surface</small>			
Description		Echelle/Scale 1:2	Mr POIGNANT 26 Rue des 3 Provinces 44190 BOUSSAY
NOMBRE : 14 PIECES		Statut	Numéro Piece / Part number PIECE 08 -
MATIERE :	ACIER ZINGUE	Poids Net / Net Weight 13.42 Kg	<small>Ce plan ne peut être reproduit ou communiqué à des tiers sans autorisation expresse de SN TECAUMA This drawing cannot be printed or issued to anybody without SN TECAUMA authorization.</small>
			folio/sheet 1/1

