

B

A

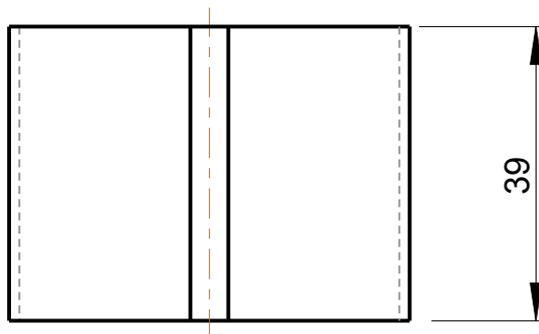
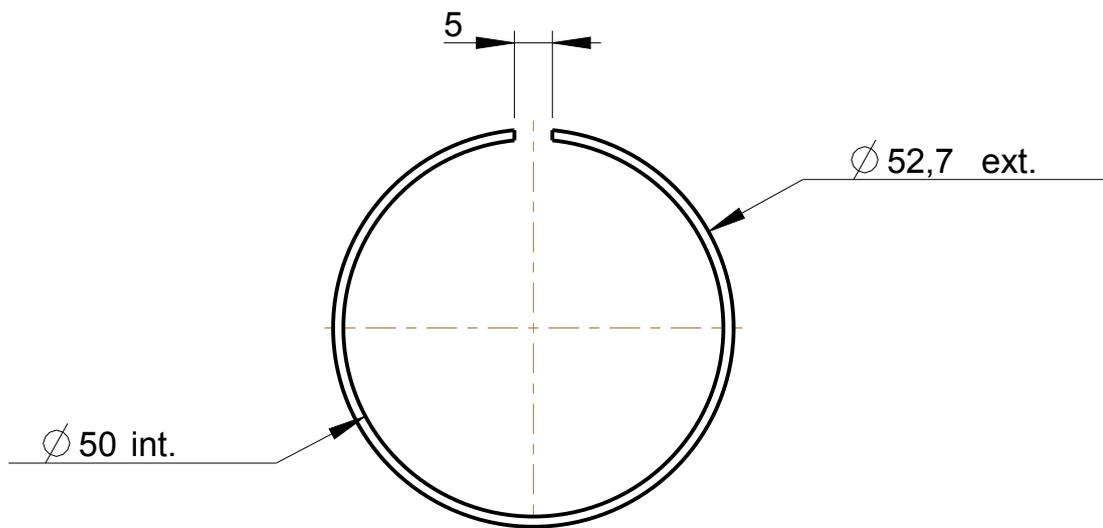

NOTICE: THIS DRAWING AND ALL DATA, DESIGNS, STRUCTURES AND DESCRIPTIONS SHOWN THEREON ARE OUR PROPERTY. ALL PATENTABLE AND/OR COPYRIGHTABLE MATTER THEREON HAS BEEN PROTECTED BY APPLICATIONS FOR PATENT AND/OR COPYRIGHT. THIS DRAWING IS LOANED FOR A SPECIFIC PURPOSE AND MUST BE RETURNED ON DEMAND. AND MAY NOT BE COPIED, REPRODUCED, OR DUPLICATED IN WHOLE OR IN PART, WITHOUT OUR SPECIFIC AUTHORIZATION IN WRITING.

MACHINE	SERIAL NUMBER	SUB ASSEMBLY	ORIGIN
SUPPLIER NAME	SUPPLIER REF	DRAWING BY	DATE

UNLESS OTHERWISE SPECIFIED :  
 - ALL DIMENSIONS MILLIMETER  
 - DO NOT SCALE DRAWING  
 - BREAK SHARP CORNERS

- REMOVE BURRS  
 - FOR DIM. WITHOUT TOL. SEE ISO 2768-mK  
 - GENERAL SURFACE ROUGHNESS Ra 3.2 ✓

METRIC



UNASSIGNED  
 MATERIAL

MASS : 0,000 KG

TITLE:



WestRock

Machinery & Automation  
 Atlanta, Georgia  
 Deols, France

1,000 SCALE	1/1 SHEETS	REVISION	STATUS	DRW. N°:	<b>ENTRETOISE</b>
----------------	---------------	----------	--------	----------	-------------------

B

A

2

1