

D

C

B

A

5

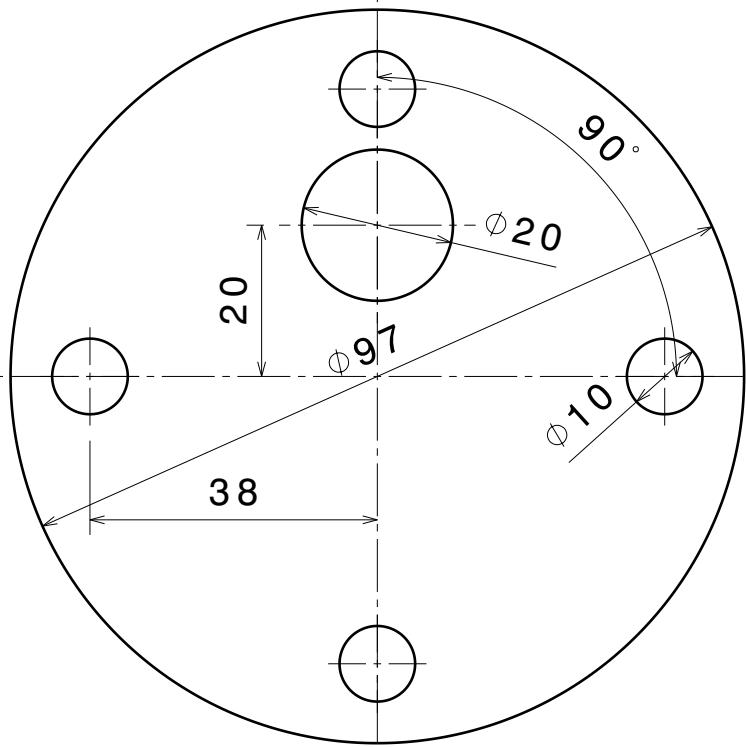

**Tolérances isométriques:**  
 - iso mk 2768  
 (se référer au tableau en page 2)

4

4

3

3

2

2

1

1

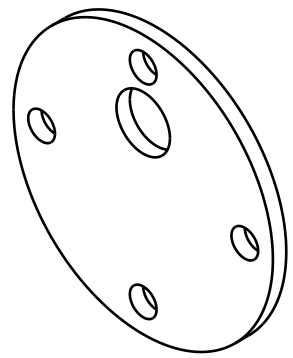

DESIGNED BY: <b>LENTZ Florian</b>	
DATE: <b>14/12/2016</b>	
CHECKED BY: /	
DATE: /	
SIZE <b>A4</b>	
SCALE <b>1:1</b>	WEIGHT (kg) <b>0.047</b>

<b>BAGUE INTERMEDIAIRE</b>		I	-
		H	-
<b>2</b>		G	-
		F	-
<b>PLP FUSEX</b>		E	-
		D	-
DRAWING NUMBER		C	-
		B	-
		A	-
SHEET		<b>1 / 1</b>	

This drawing is our property; it can't be reproduced or communicated without our written agreement.

D

A

**Tolérances isométriques d'usinage:**

Classe de précision	Dimension linéaire					Angle cassé (chanfrein ou rayon)			Dimension angulaire (côté le plus court)			
	>0,5 à 3 inclus	>3 à 6	>6 à 30	>30 à 120	>120 à 400	>0,5 à 3 inclus	>3 à 6	>6	≤10	>10 à 50 inclus	> 50 à 120	>120 à 400
f (fin)	±0,05	±0,05	±0,1	±0,15	±0,2	±0,2	±0,5	±1	±1°	±30'	±20'	±10'
m (moyen)	±0,1	±0,1	±0,2	±0,3	±0,5	±0,2	±0,5	±1	±1°	±30'	±20'	±10'
c (large)	±0,2	±0,3	±0,5	±0,8	±1,2	±0,4	±1	±2	±1°30'	±1°	±30'	±15'
v (très large)	—	±0,5	±1	±1,5	±2,5	±0,4	±1	±2	±3°	±2°	±1°	±30'

DESIGNED BY: <b>LENTZ Florian</b>		<b>BAGUE INTERMEDIAIRE</b>		I	-
DATE: <b>14/12/2016</b>				H	-
CHECKED BY: /		<b>2</b>		G	-
DATE: /				F	-
SIZE <b>A4</b>		<b>PLP FUSEX</b>		E	-
SCALE <b>1:5</b>	WEIGHT (kg) <b>0.047</b>			D	-
DRAWING NUMBER /		C	-		
SHEET <b>1/1</b>		B	-		
This drawing is our property; it can't be reproduced or communicated without our written agreement.		A	-		