

Chanfrein 0.5 mm
 taraudage m4 traversant
 (x 8) à 45° sur diam 23mm +/- 0.05 mm

COUPE A-A

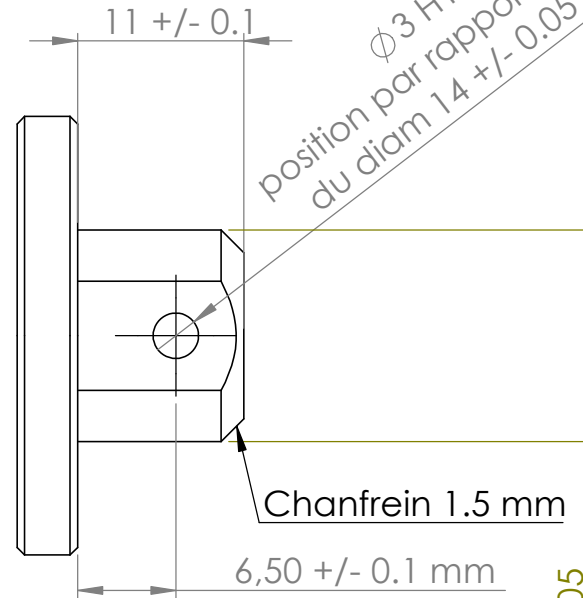

$\phi 3$ H11
 position par rapport à l'axe
 du diam 14 +/- 0.05 mm

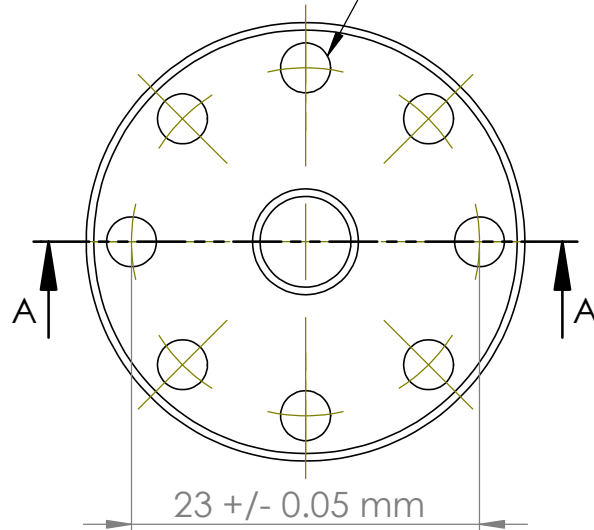
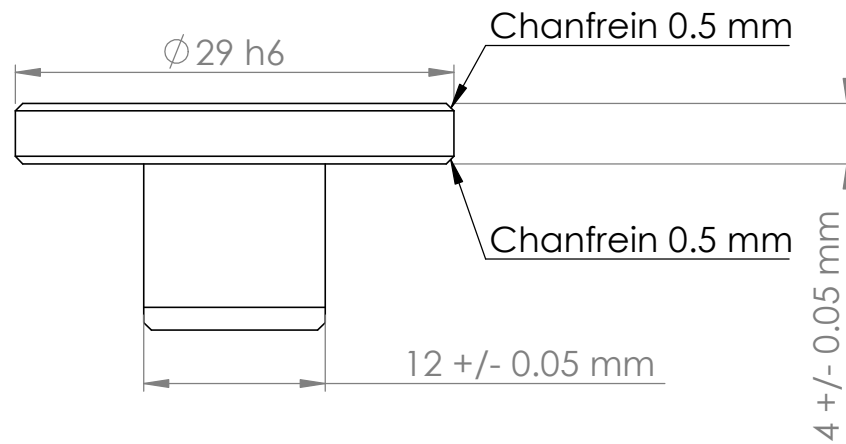

$\phi 14 +/- 0.05$

matière AU4G
 quantité = 1

SAUF INDICATION CONTRAIRE:
 LES COTES SONT EN MILLIMETRES
 ETAT DE SURFACE:
 TOLERANCES:
 LINEAIRES:
 ANGULAIRES:

FINITION:

CASSER LES
 ANGLES VIFS

NE PAS CHANGER L'ECHELLE

REVISION

NOM

SIGNATURE

DATE

TITRE: