

fraisage pour vis m3 totalement noyée sur diam 21 +/- 0.05 mm

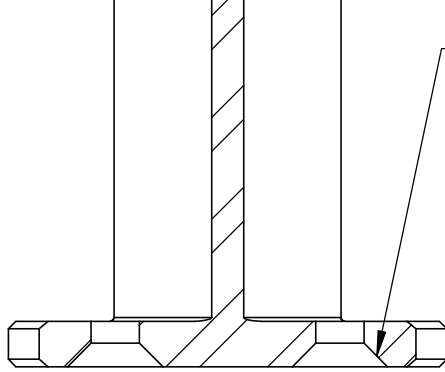

COUPE B-B

diam 23 +/- 0.05 mm

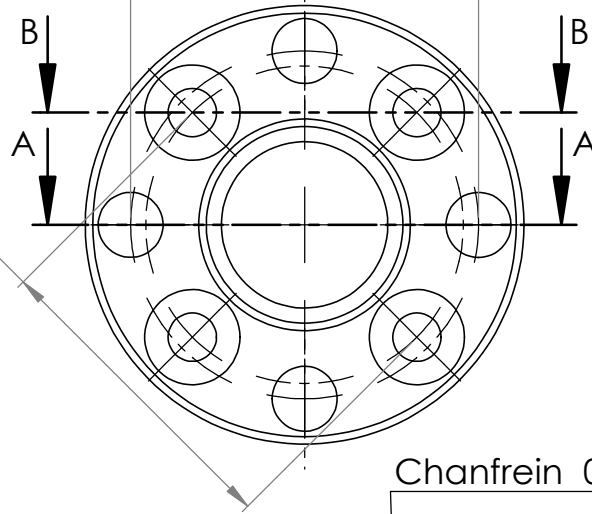

$\phi 1 \pm 0.05 \text{ mm}$

Chanfrein 0.5 mm

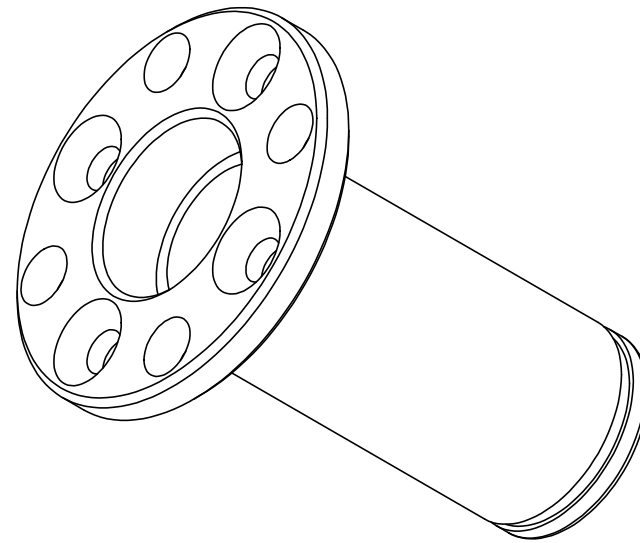

37,75 +/- 0.05 mm

32 +/- 0.05 mm

$\phi 29 \text{ h6}$

3 +/- 0.05 mm

matière AU4G
quantité = 1

H11

Chanfrein 0.5 mm

Chanfrein 0.5 mm

SAUF INDICATION CONTRAIRE:
LES COTES SONT EN MILLIMETRES
ETAT DE SURFACE:
TOLERANCES:
LINEAIRES:
ANGULAIRES:

FINITION:

CASSER LES
ANGLES VIFS

NE PAS CHANGE

	NOM	SIGNATURE	DATE				TITRE:
--	-----	-----------	------	--	--	--	--------