

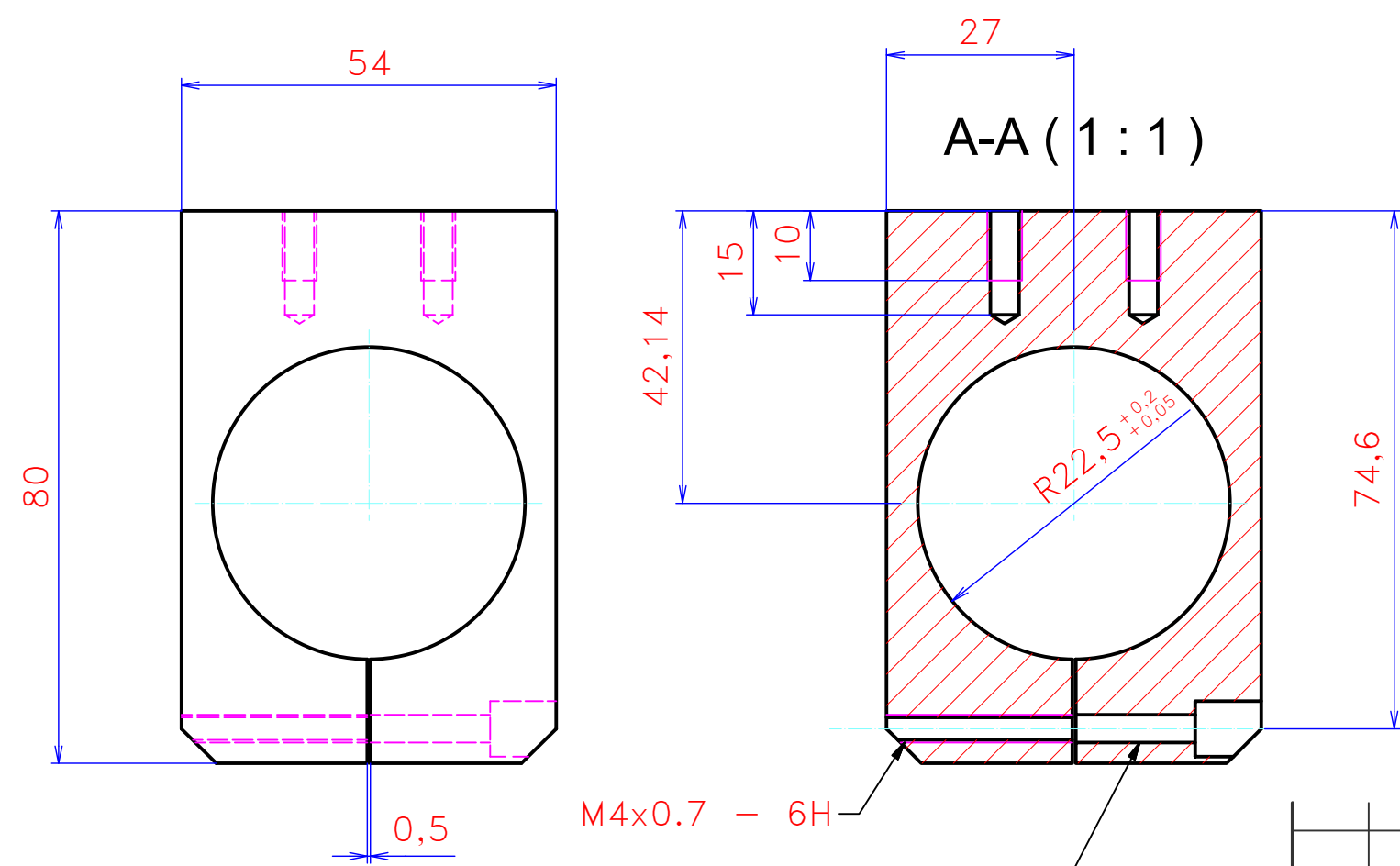

A
A

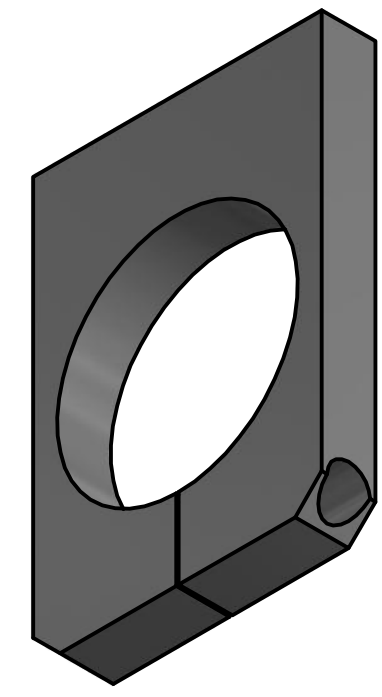
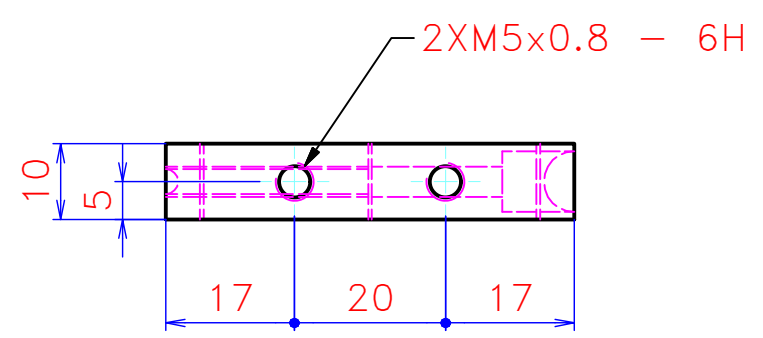

27
A-A (1:1)

M4x0.7 - 6H
 $\varnothing 4 - 37,5$ Profondeur
 $\square \varnothing 8 \nabla 20$



13/11/16	ALGOPTIC	BE	SC	PREMIERE EDITION	A
DATE	ETs.	SERVICE	NOM	MODIFICATIONS	IND.
ECHELLE	DESIGNATION :			MATIERE	
	BAXTER GAMBRO			Aluminium Anodisé	
	pince support tube rallonge			TRAITEMENT	
				ANNOD INC	
				BRUT	
RESPONSABLE D'AFFAIRE :			DESSINE PAR :		
NOM	SERVICE	ETABLISSEMENT	NOM	SERVICE	ETABLISSEMENT
		MACLAS	Seb	BE	ALGOPTIC
					13/11/16
FORMAT	CE DOCUMENT EST LA PROPRIETE D'ALGOPTIC. IL NE PEUT PAS ETRE UTILISE, REPRODUIT OU COMMUNIQUE SANS UNE AUTORISATION ECRITE		 113 Place de l'Église, 42520 Maclas TEL : 04 74 48 21 81		
A3			AUTRE NUMERO :		
	N° DE PLAN	ALGOP-0010		PLANCHE	
		<input type="checkbox"/> SPECIFIQUE <input type="checkbox"/> STANDARD		SUFFIXE	

Sauf indications contraire
 Cotes sans Tolerances : Js13
 Casser les angles 0,5 a 45
 Etat de surface : Ra 3.2