

Vue de face
Front view

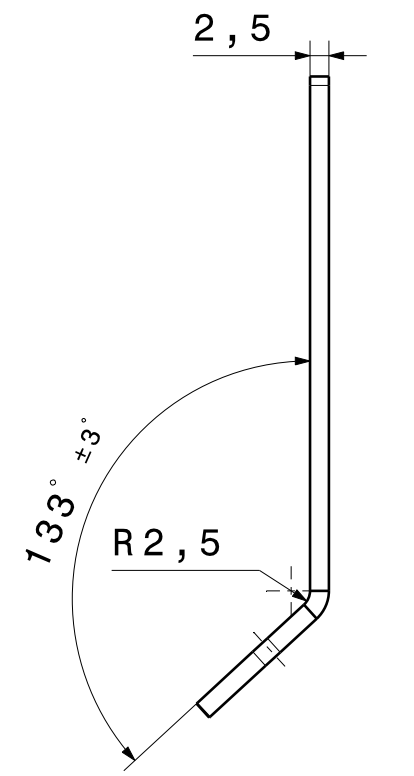

Vue de face
Front view

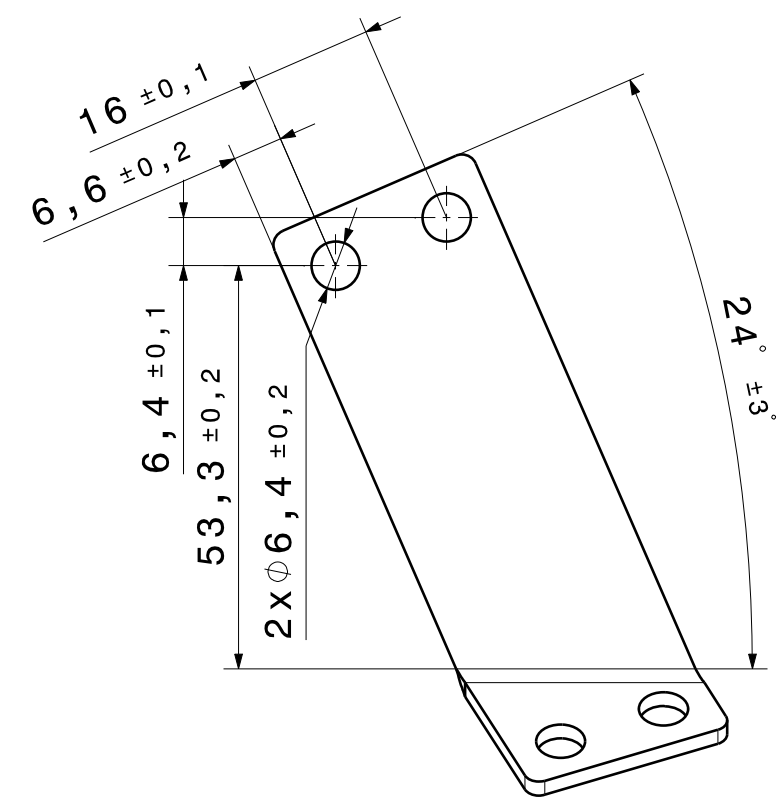

Vue de gauche
Left view

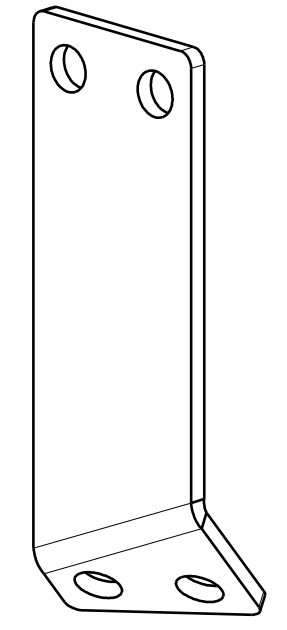

Vue isométrique
Isometric view

SPECIFICATIONS / SPECIFICATIONS

- △ = CARACTERISTIQUES CONDITIONS / SPECIAL CHARACTERISTICS
- △ - CODE DE PROPRETE = A (B-/C18/D17/E15/FGH12/I3/JK00) SUIVANT LA NORME ISO 16 232
- △ - CLEANLINESS CODE = A (B-/C18/D17/E15/FGH12/I3/JK00) ACCORDING TO ISO 16 232
- ETAT GENERAL DES BORDS SUIVANT ISO 13715
- GENERAL ASPECT OF EDGES ACCORDING TO ISO 13715

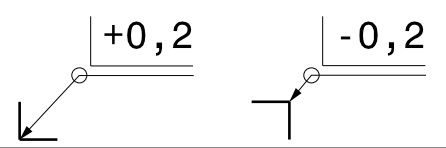

Validation Project							
Validation Quality							
Validation Engineering							
Validation Purchasing							
IND. PI. PART C.L.	IND. PL. DWG C.L.	ETAIT AVANT MODIFICATION WAS BEFORE MODIFICATION			DATE DATE	PAR BY	NB MODI. MODIF. QTY

METHODE DE PROJECTION PROJECTION METHOD ISO 128-1 	DESSINE DRAWN 22/07/2016	JOUR DAY	NOM NAME VIDICAN G.
SURFACE SURFACE ISO 1302	APPROUVE APPROVED	DESIGNATION : DESIGNATION :	
TOLERANCE DE FORME ET DE POSITION FORM AND POSITION TOLERANCE ISO 1101	ECHELLE SCALE 1:1	MATERIE / MATERIAL : Acier Inoxydable	
TOLERANCE GENERALE GENERAL TOLERANCE ISO 2768 -mK	REFERENCE / PART NUMBER : 18090-130500		
FORMAT SIZE A3	FLEXITECH Europe SAS 293, rue des Sagnes 42210 Saint-André-le-Puy FRANCE 		

Chemin d'accès : W:\FLMR_R&D_ASSEMBLAGE\05 - Plans CAO\Catia\Divers\Indus\Banc de gym\BMW_F15\18090-130500

CAO
DESSIN
CATIA
MODIFICATION
A LA PLANCHE
INTERDITE

Patte support

18090-130500