

DÉTAIL A ECHELLE 1 : 2

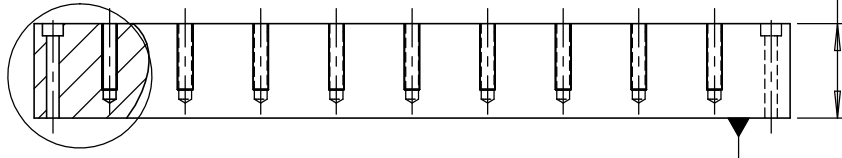

50 ± 0,10
// 0.05 A

A

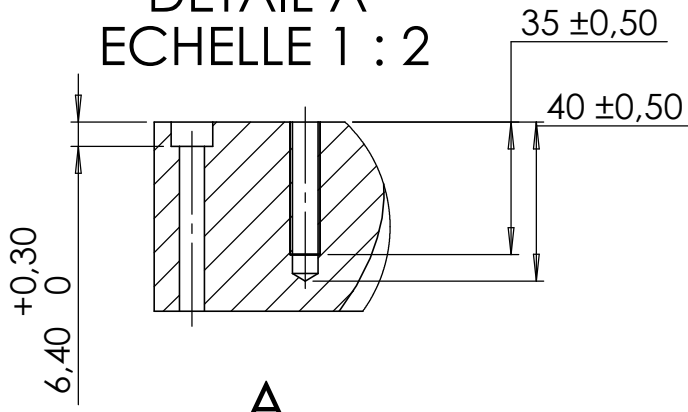
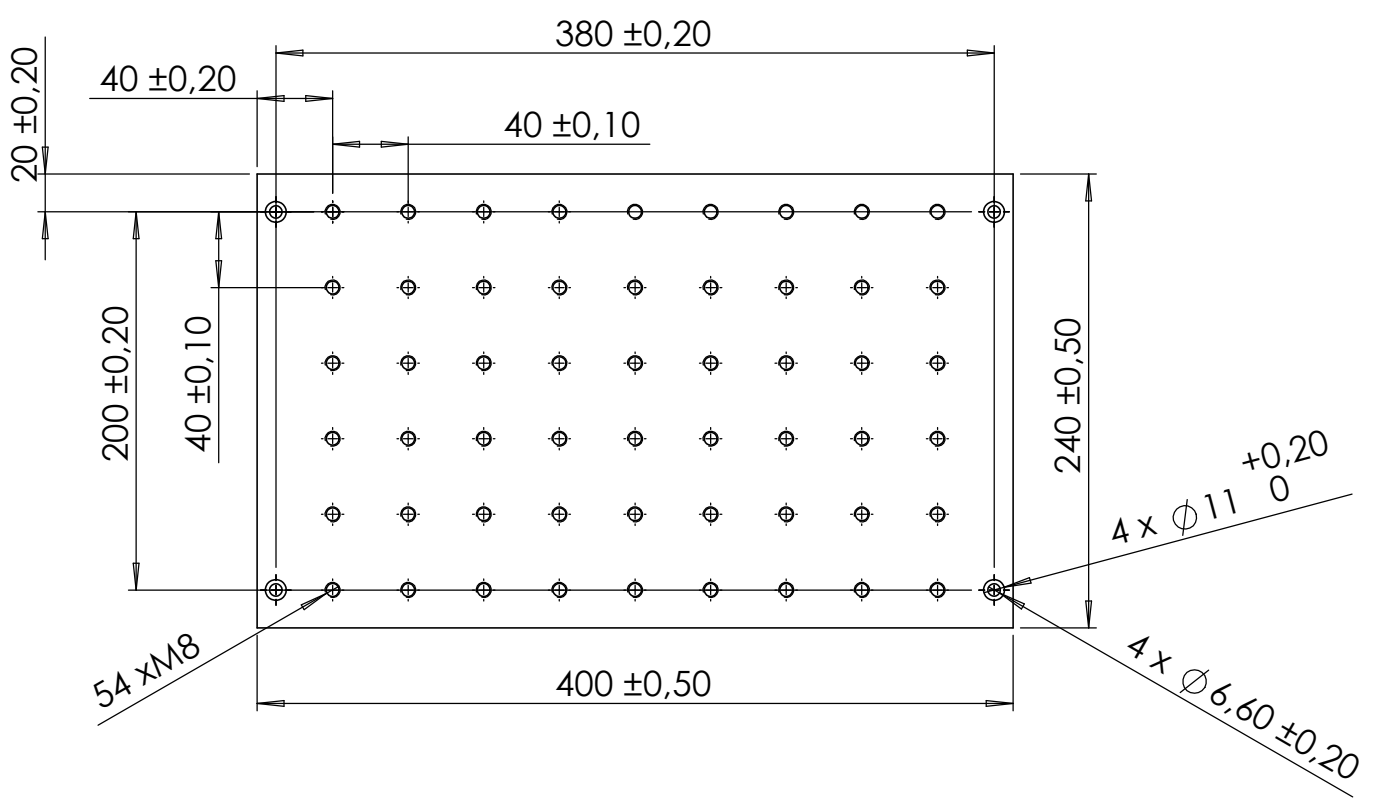

SAUF INDICATION CONTRAIRE: LES COTES SONT EN MILLIMETRES ETAT DE SURFACE: TOLERANCES: LINEAIRES: ANGULAIRES:				FINITION:		CASSER LES ANGLES VIFS		NE PAS CHANGER L'ECHELLE		REVISION	
NOM				SIGNATURE		DATE		TITRE:			
AUTEUR											
VERIF.											
APPR.											
FAB.											
QUAL.						MATERIAU:		No. DE PLAN		Table	
								Echelle: 1:5		FEUILLE 1 SUR 1	
										A4	