

INDICE	MODIFICATION	NOM ET DATE

Coupe B-B
Echelle : 3:10

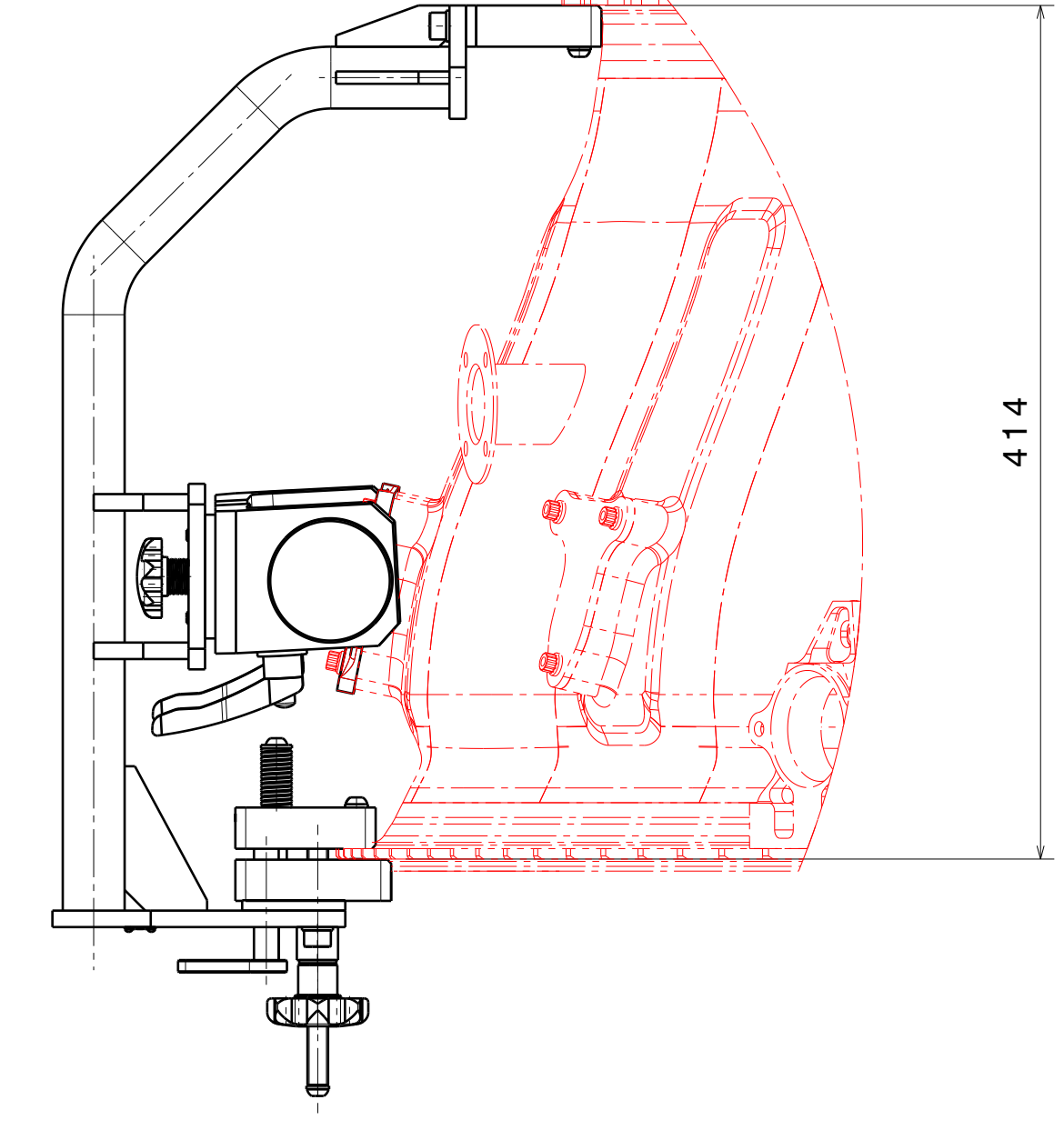
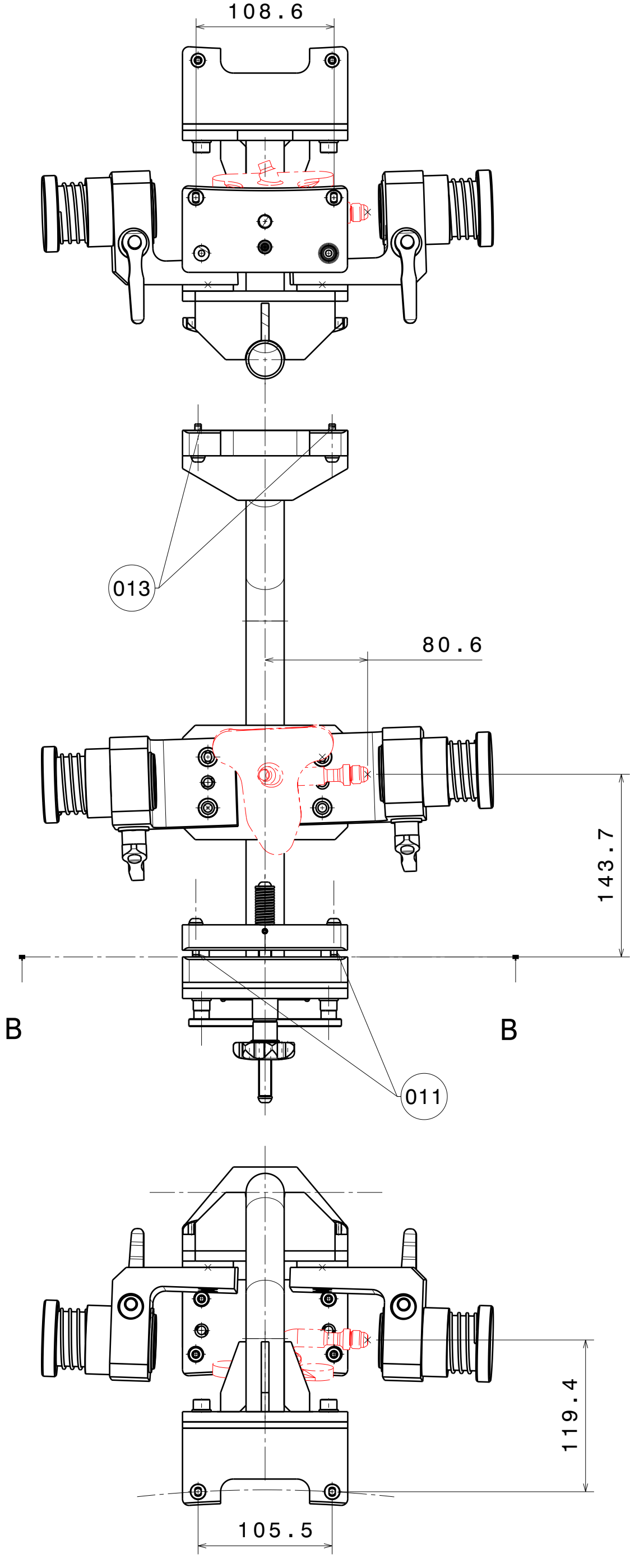

OUTILLAGE DE CONTROLE TUBE EXTERIEUR
TYPE "MAMELON ARRIVE"

Coupe A-A
Echelle : 3:10

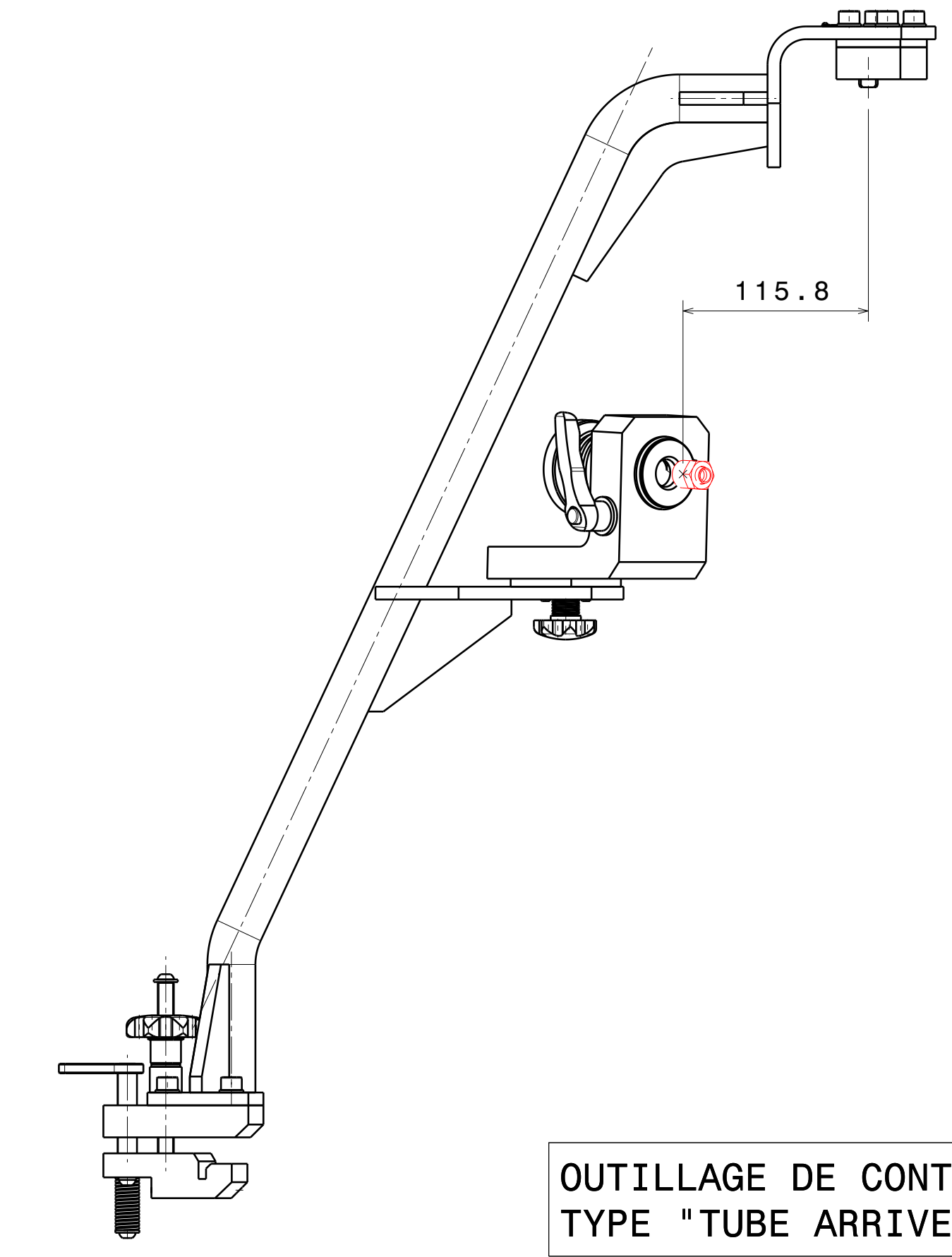
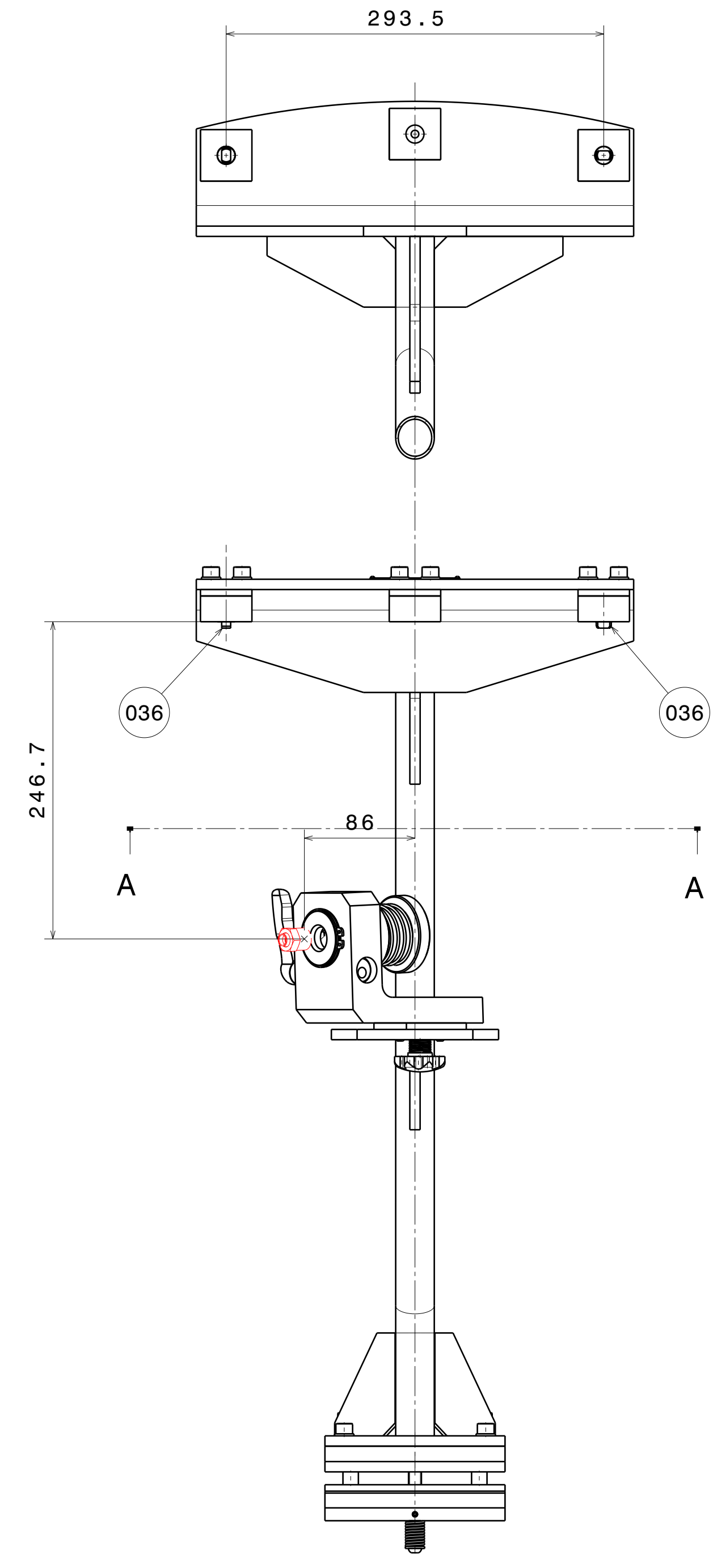

OUTILLAGE DE CONTROLE TUBE INTERIEUR
TYPE "TUBE ARRIVE HUILE"

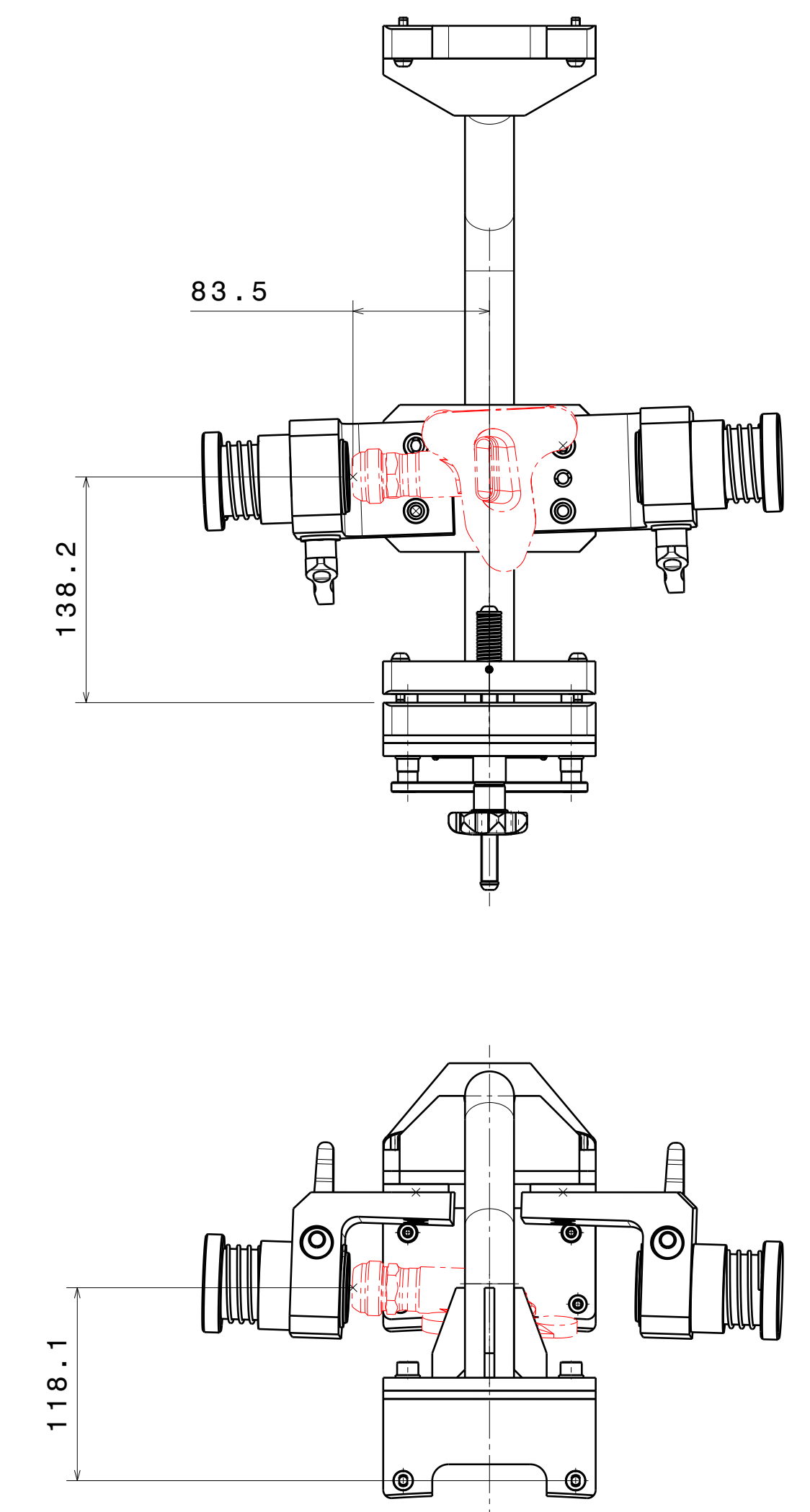

OUTILLAGE DE CONTROLE TUBE EXTERIEUR
TYPE "MAMELON DEPART"

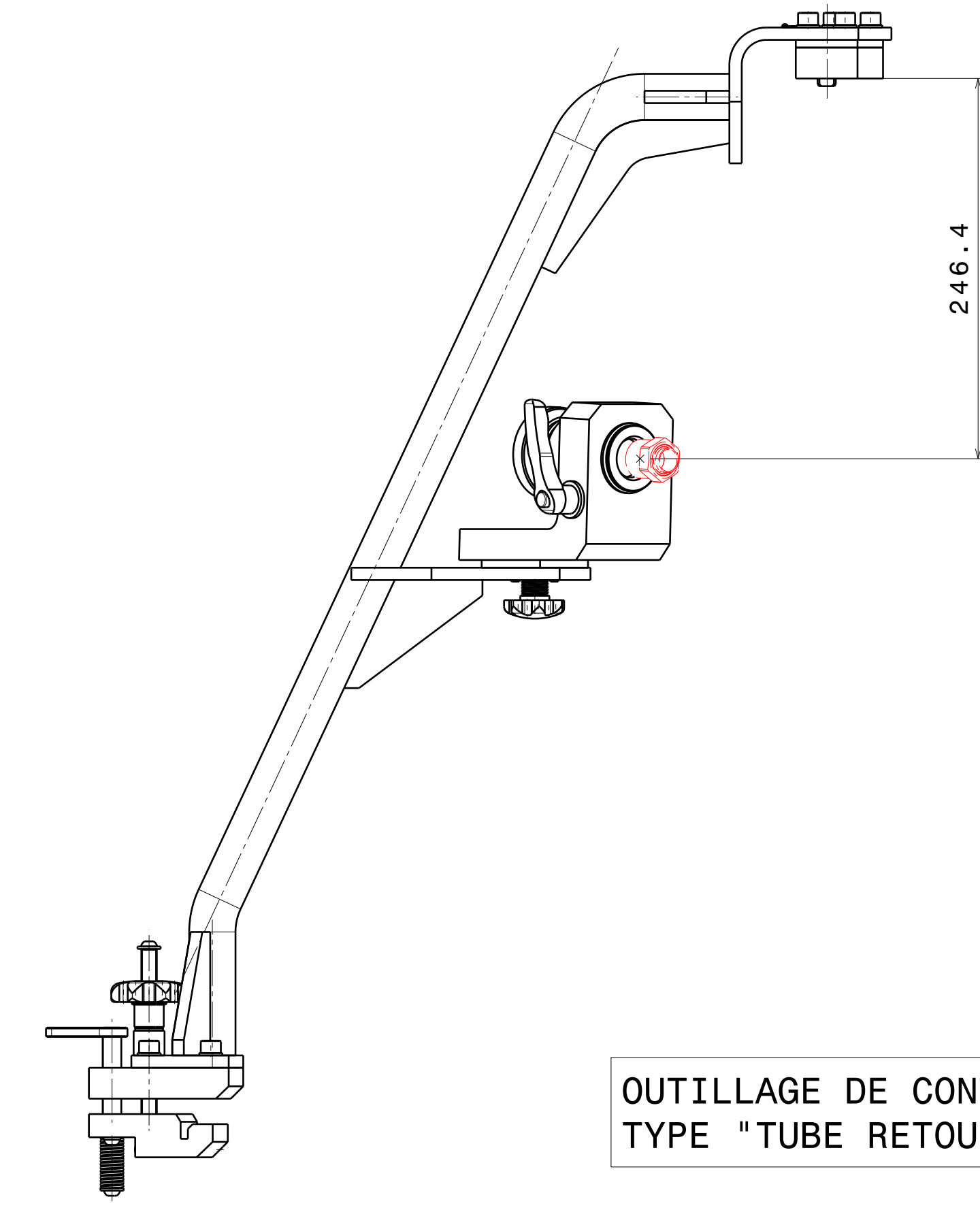
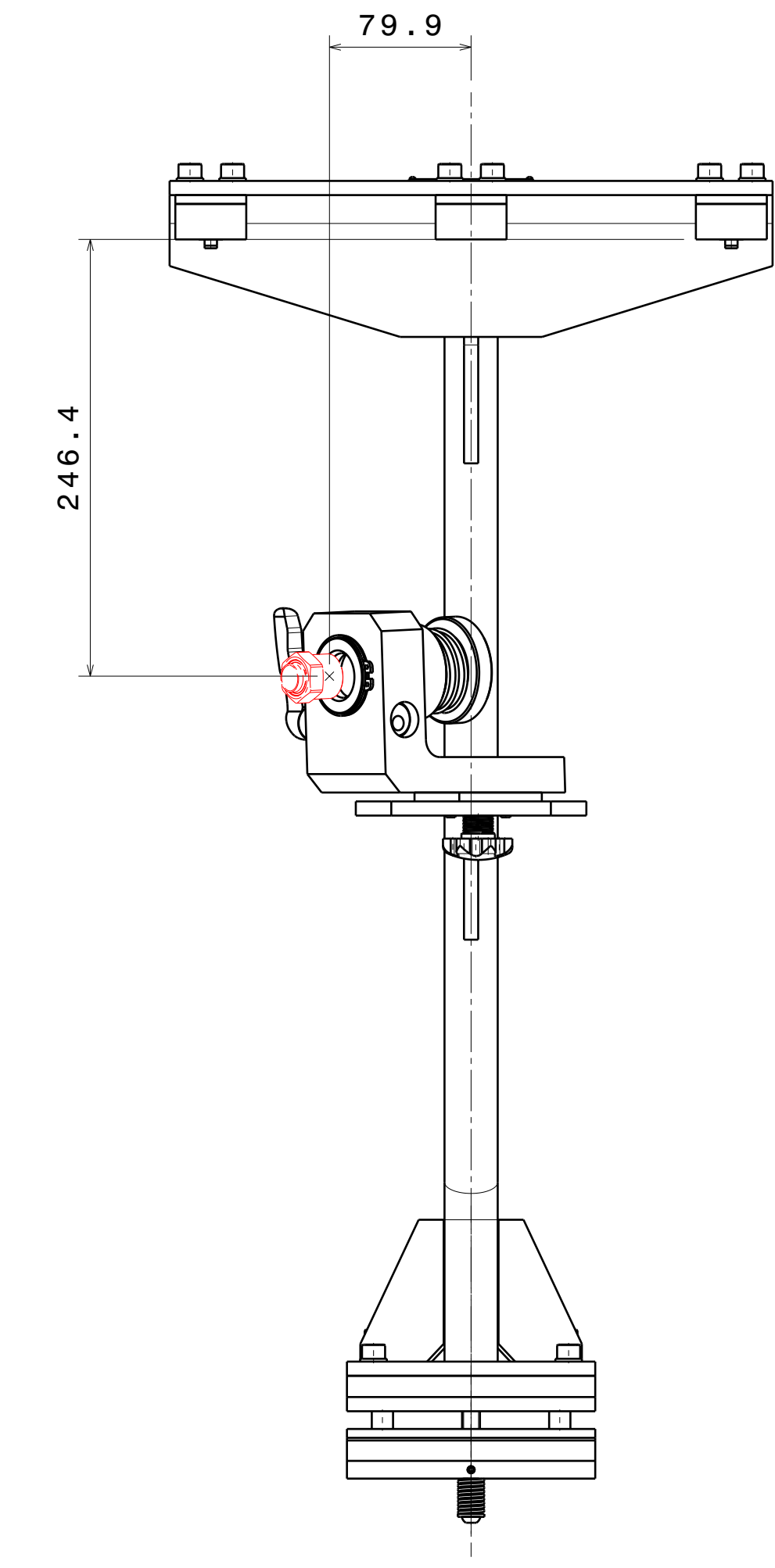

OUTILLAGE DE CONTROLE TUBE INTERIEUR
TYPE "TUBE RETOUR"

MODIF	PL	REP	QTE	DESIGNATION	MATERIES ET TRAITEMENTS
SOUS-TRAITANT				METHODES	QUALITE
Dessine par : LI SGO		Dessine par :		Verifie par :	
Verifie par : LI SGO		Verifie par :		Verifie par :	
UTILISE POUR :					
CARTER ECHAPPEMENT					
DESIGNATION : OUTILLAGE DE CONTROLE POSITION TUBES					ECHELLE 1/1
ETUDE OUTILLAGES					
No: 1-135-1-2704-00-000					PL 9/9