

2		1
INDICE	MODIFICATION	NOM ET DATE

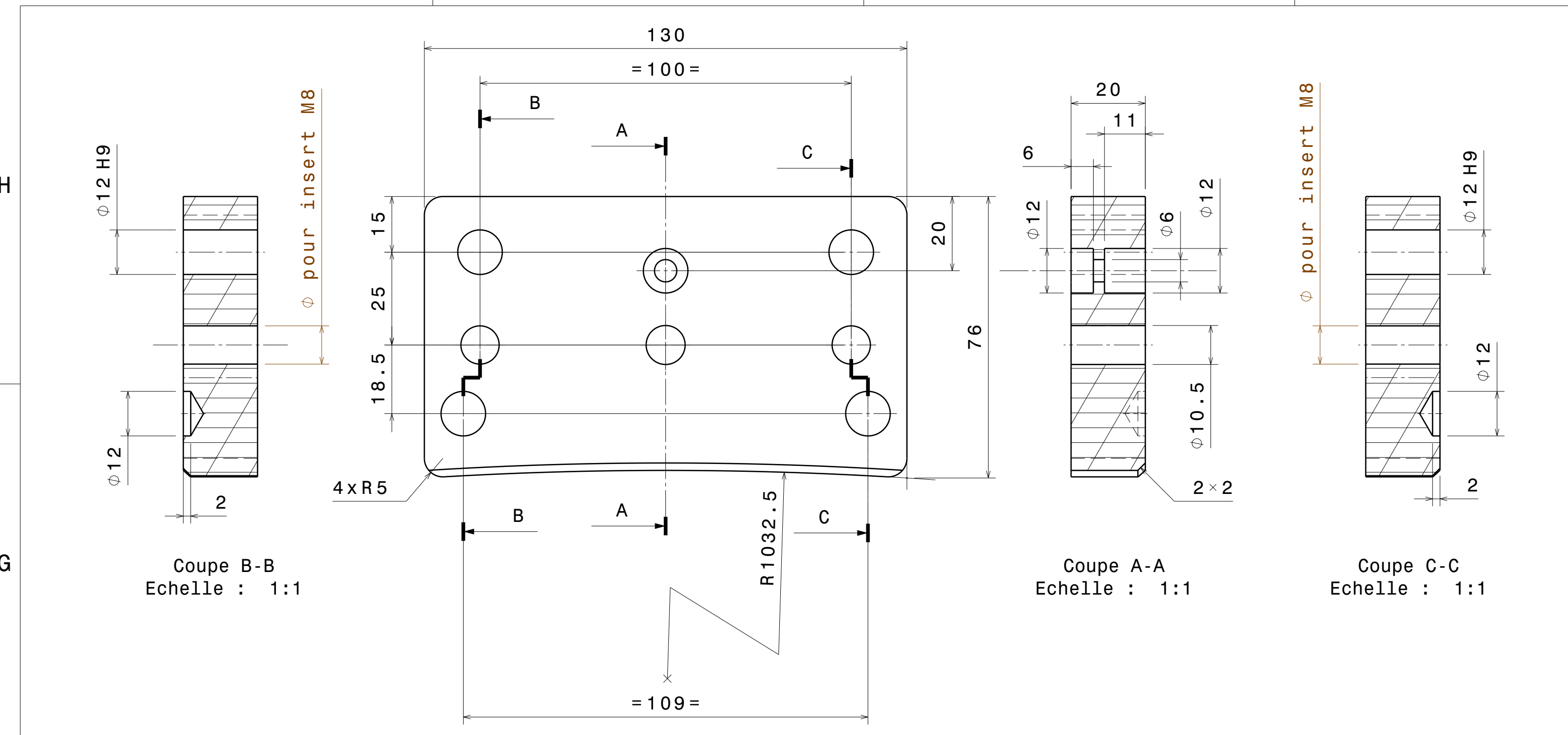

Tolérance générale suivant : ISO 2768 m-K
Casser les angles vifs

1	MACHOIRE FIXE	HD500	1-135-1-2704	00	008
---	---------------	-------	--------------	----	-----

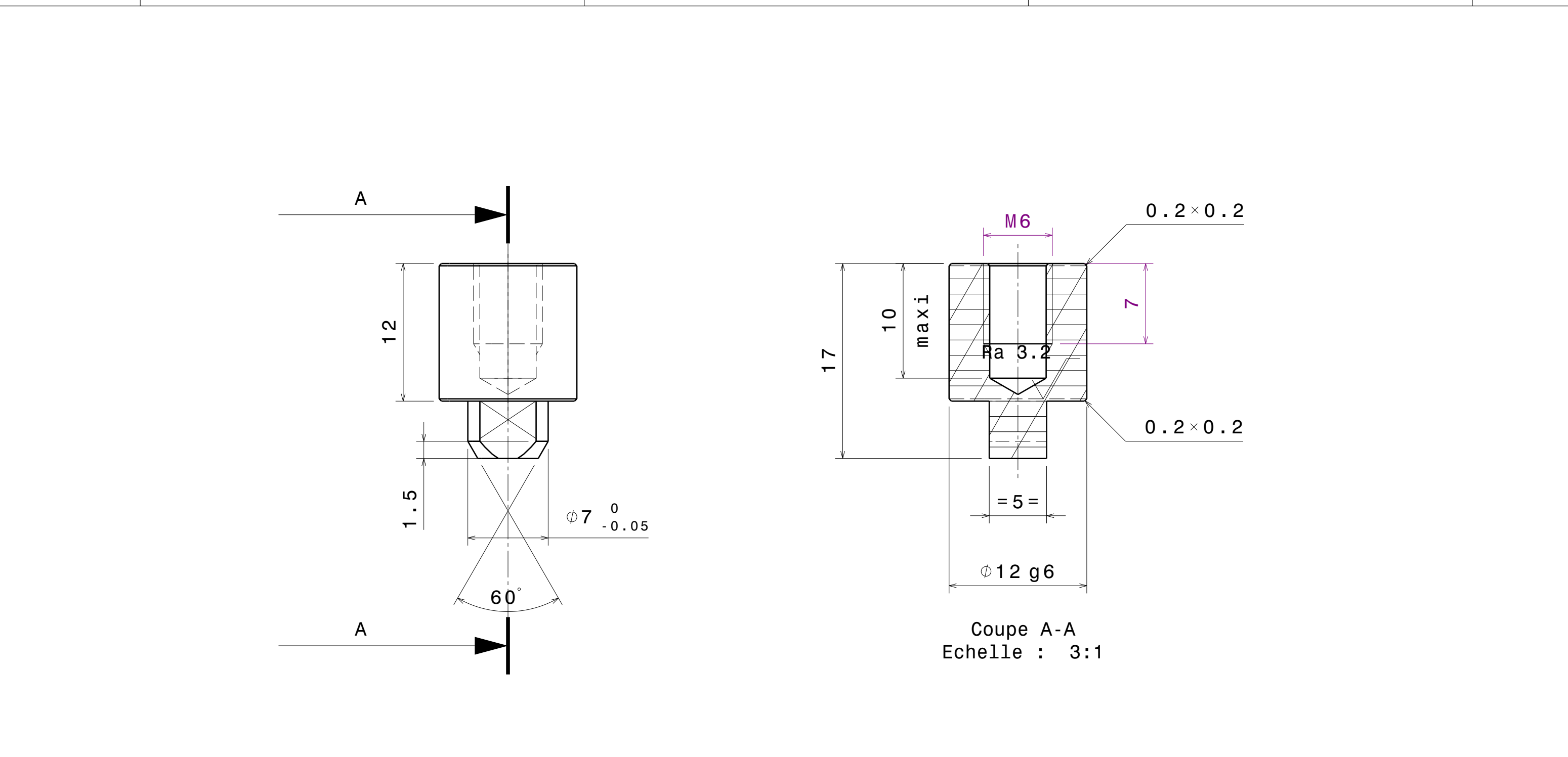

Tolérance générale suivant : ISO 2768 m-K
Casser les angles vifs

2	PION	PA6	1-135-1-2704	00	013
---	------	-----	--------------	----	-----

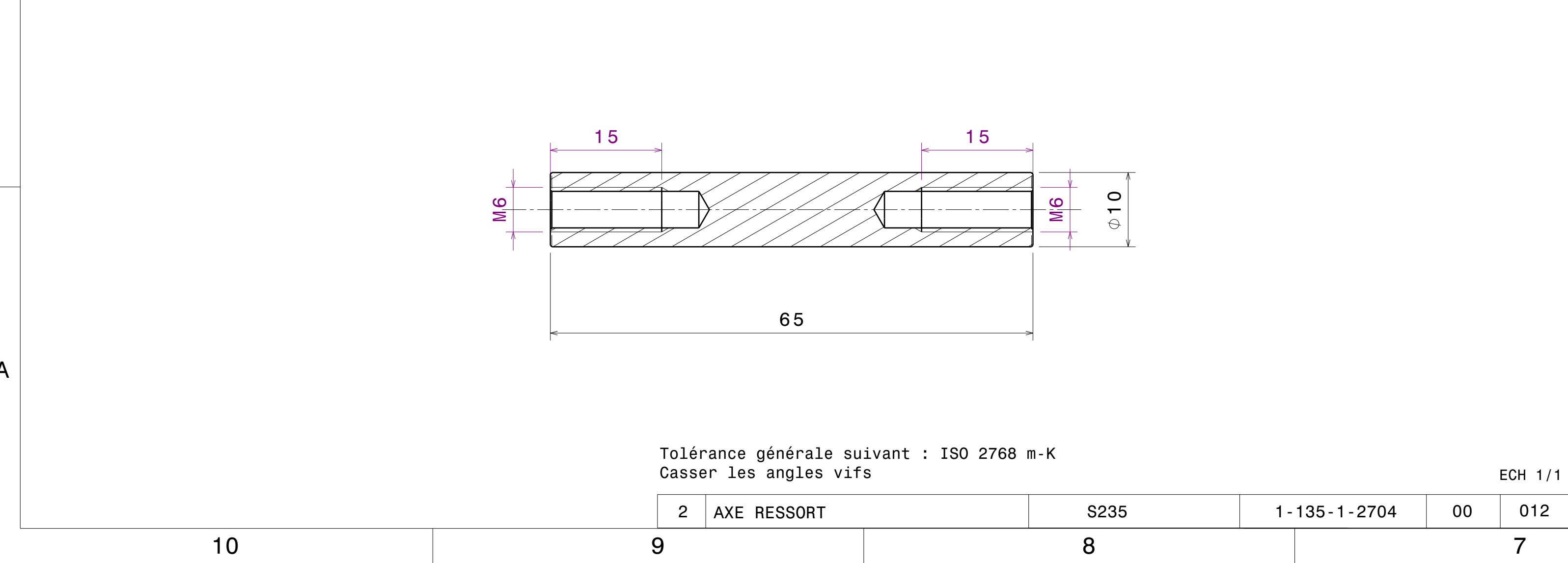
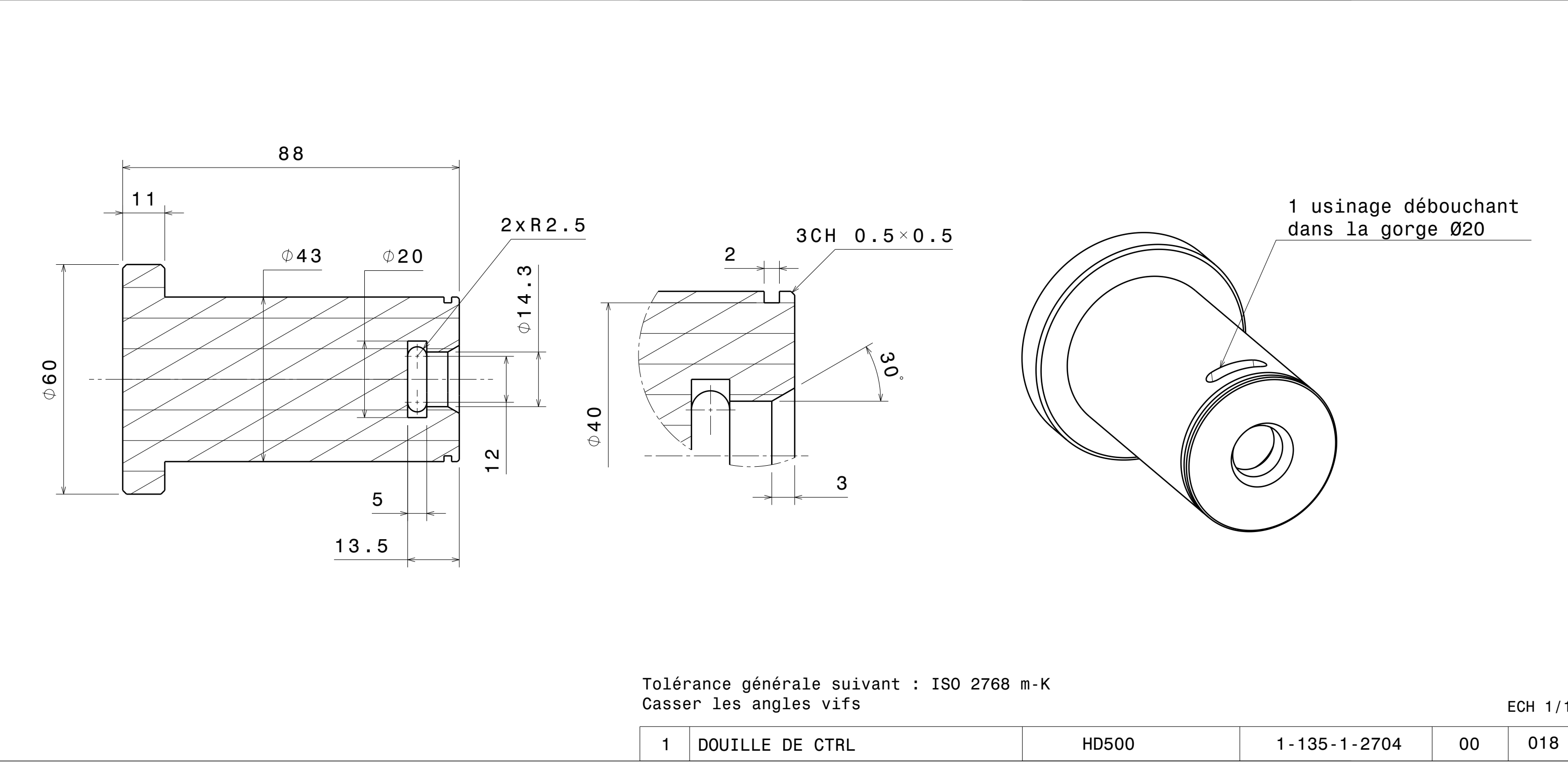
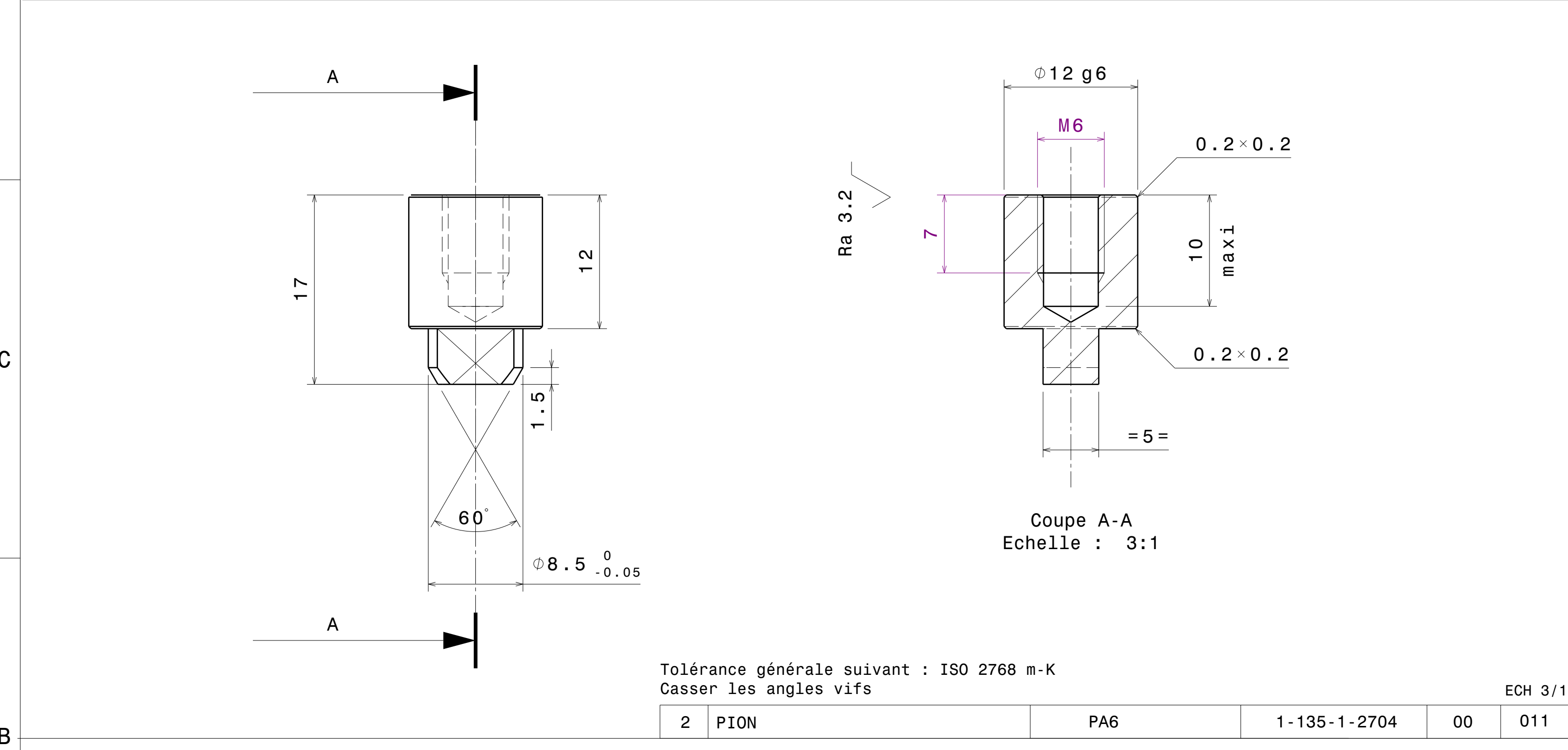
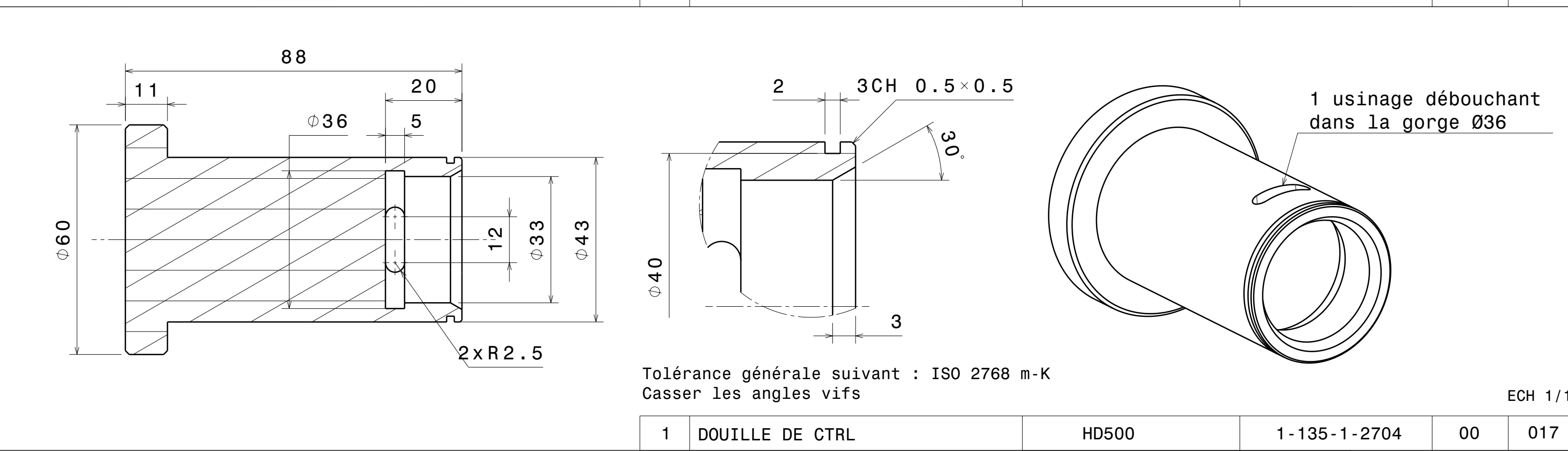
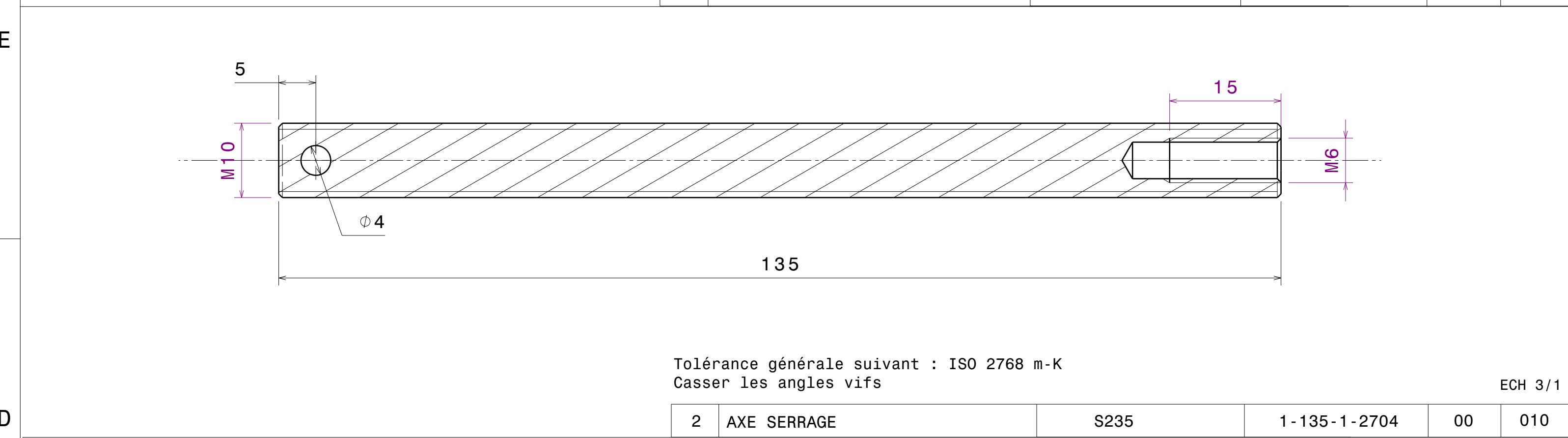
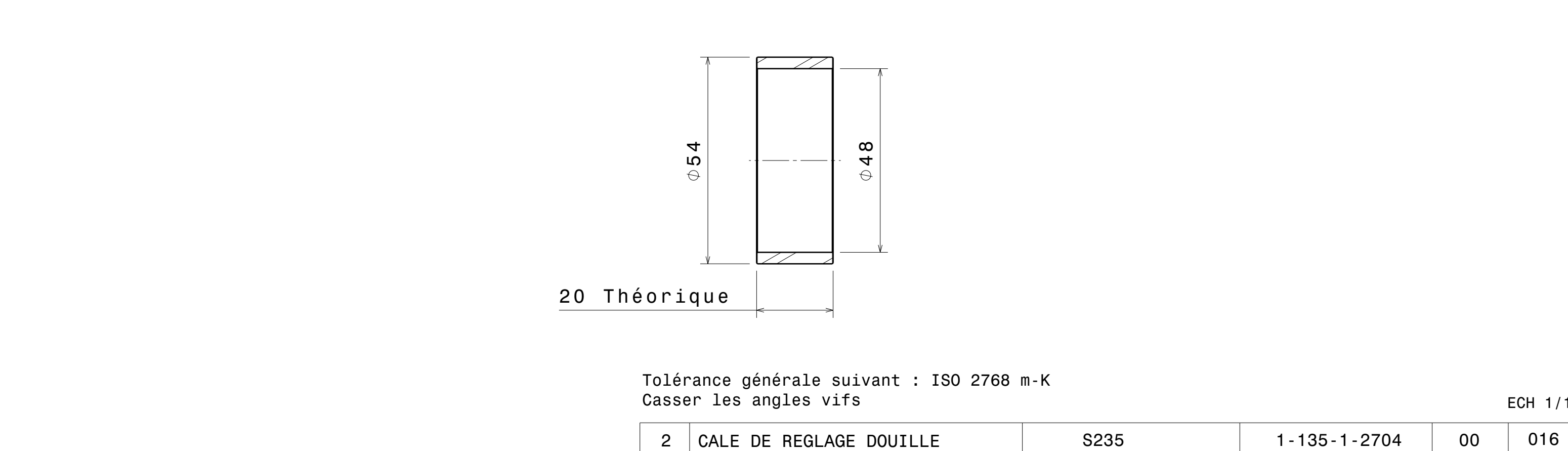
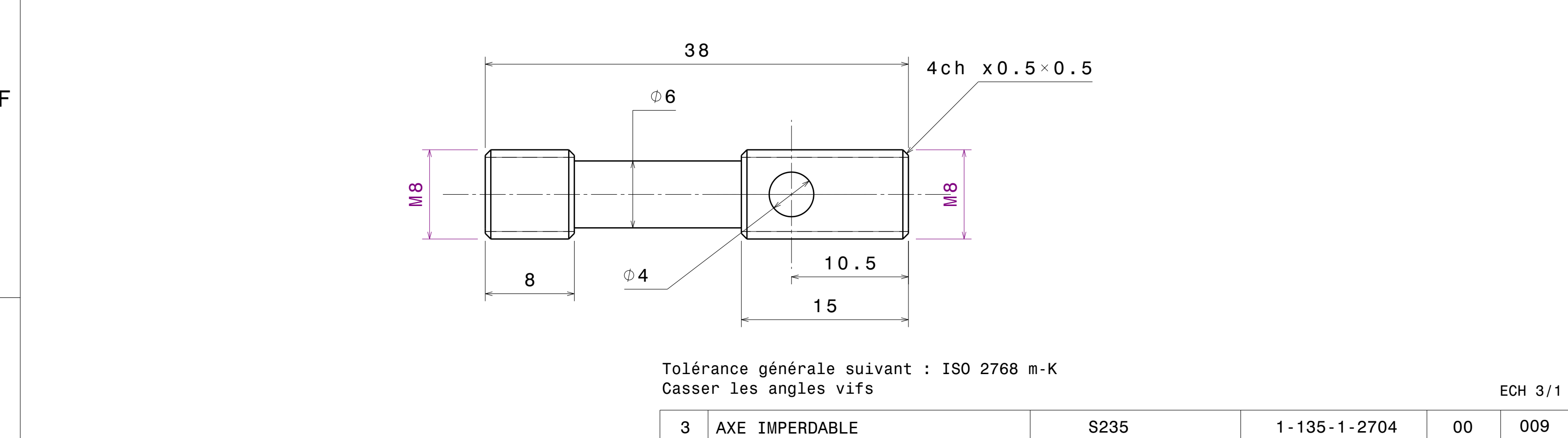

MODIF	PL	REP	QTE	DESIGNATION	MATIERES ET TRAITEMENTS
SOUS-TRAITANT				METHODES	QUALITE
Dessiné par : LI SGO		Dessiné par :			
Vérifié par : LI SGO		Vérifié par :			
UTILISE POUR :					
CARTER ECHAPPEMENT					
DESIGNATION : OUTILLAGE DE CONTROLE POSITION TUBES				ECHELLE	.
ETUDE OUTILLAGES					PL
No: 1-135-1-2704-00-000					5/9