

INDICE	MODIFICATION	NOM ET DATE

Coupe A-A  
Echelle : 3:5

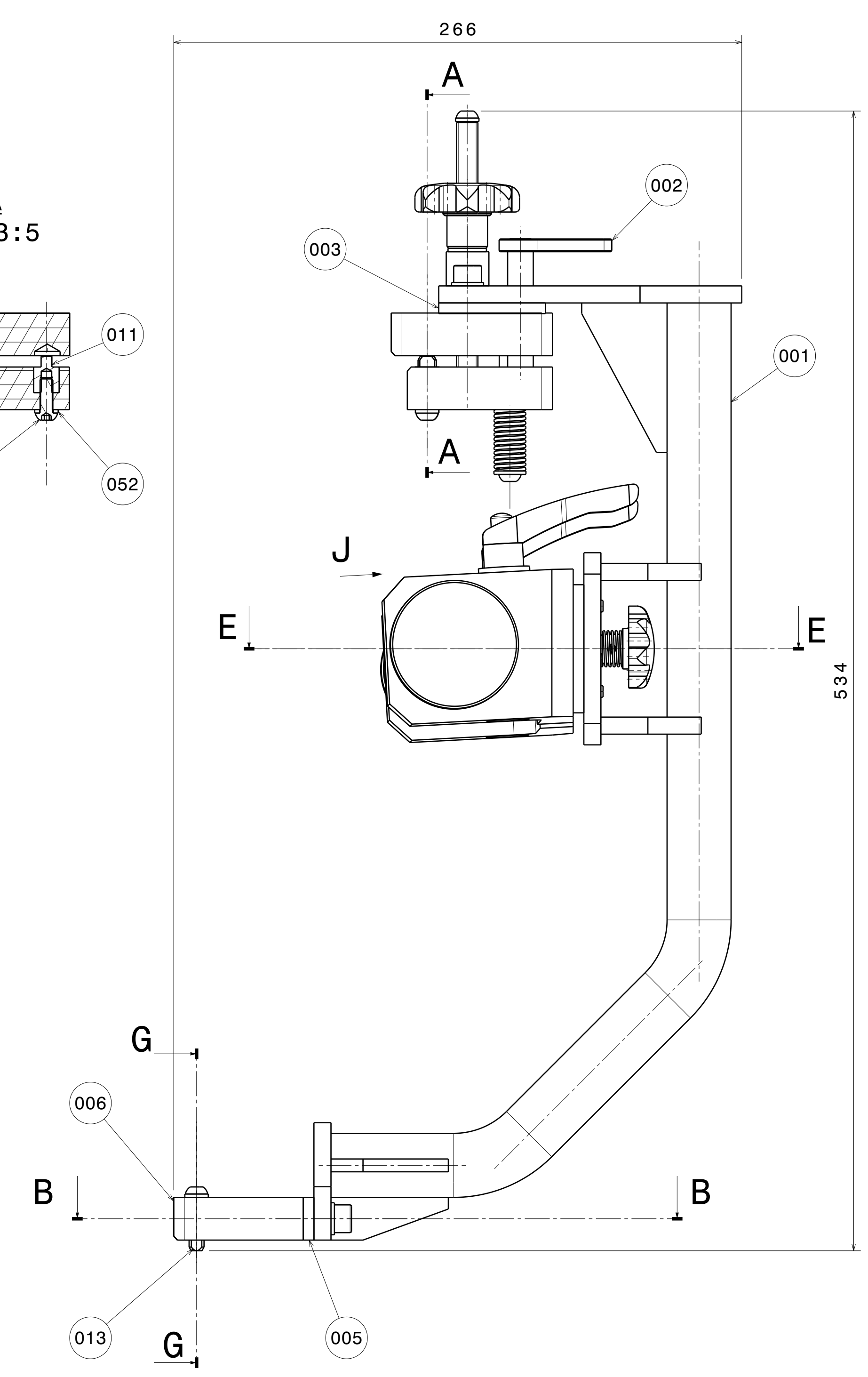

Vue auxiliaire J  
Echelle : 3:5

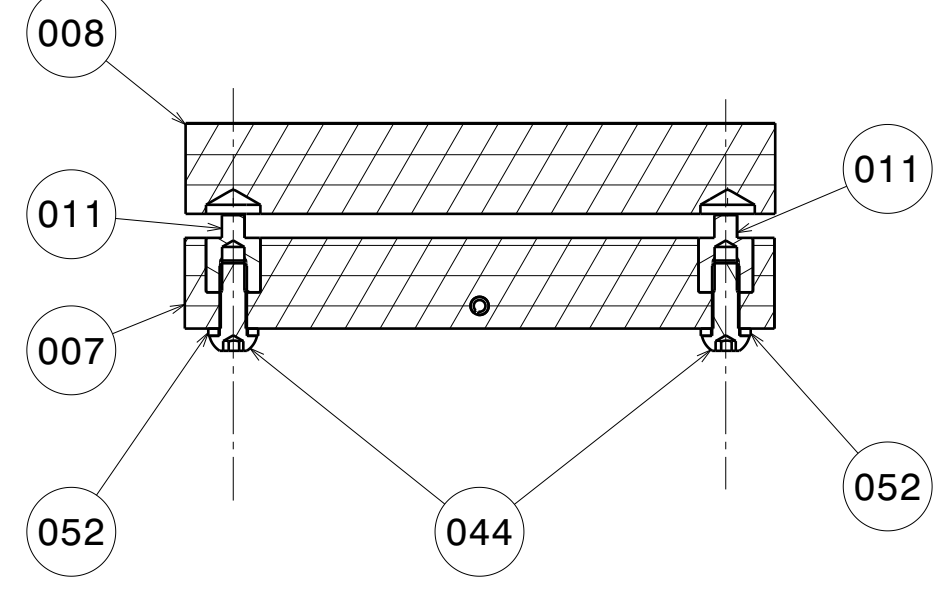
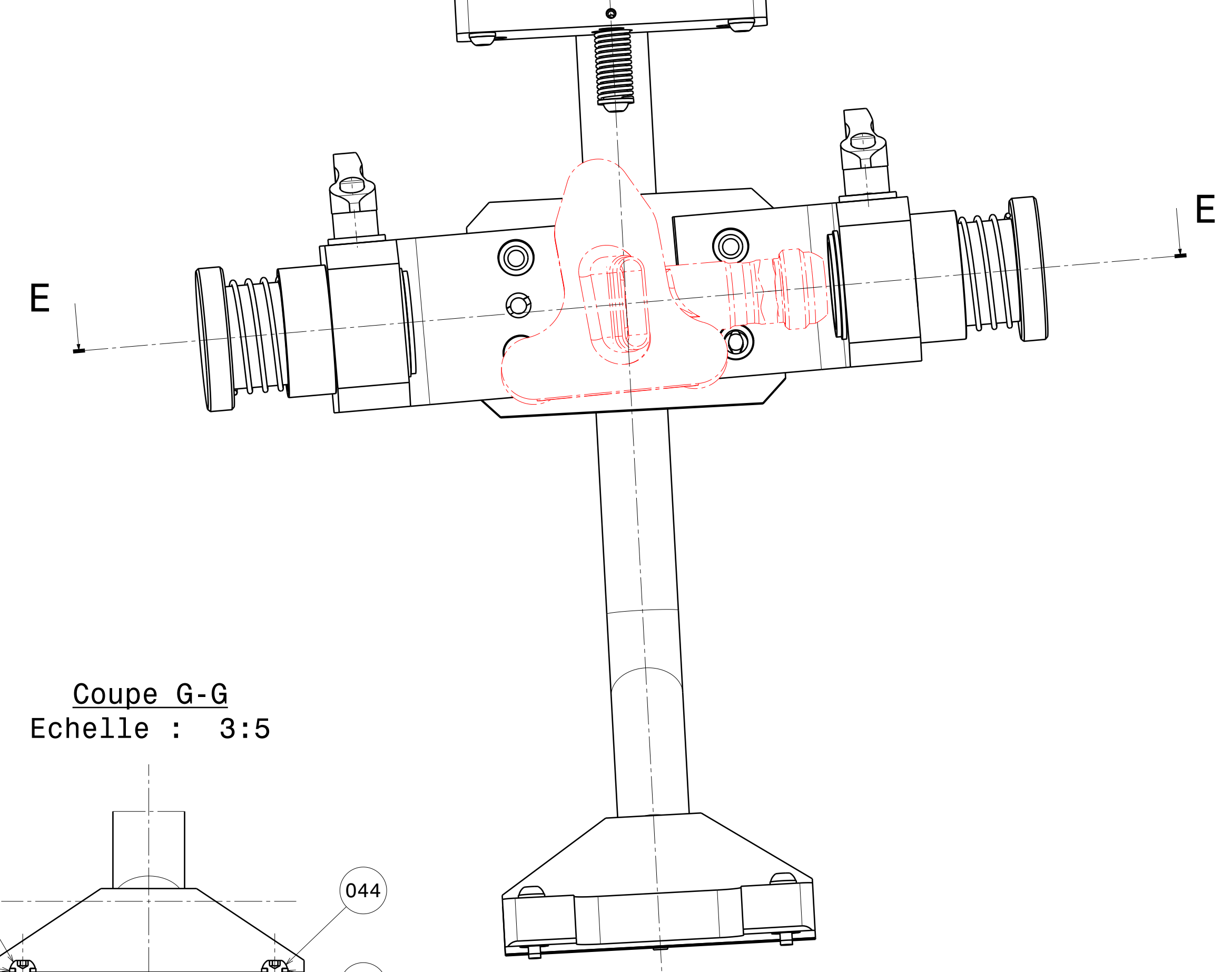

Coupe G-G  
Echelle : 3:5

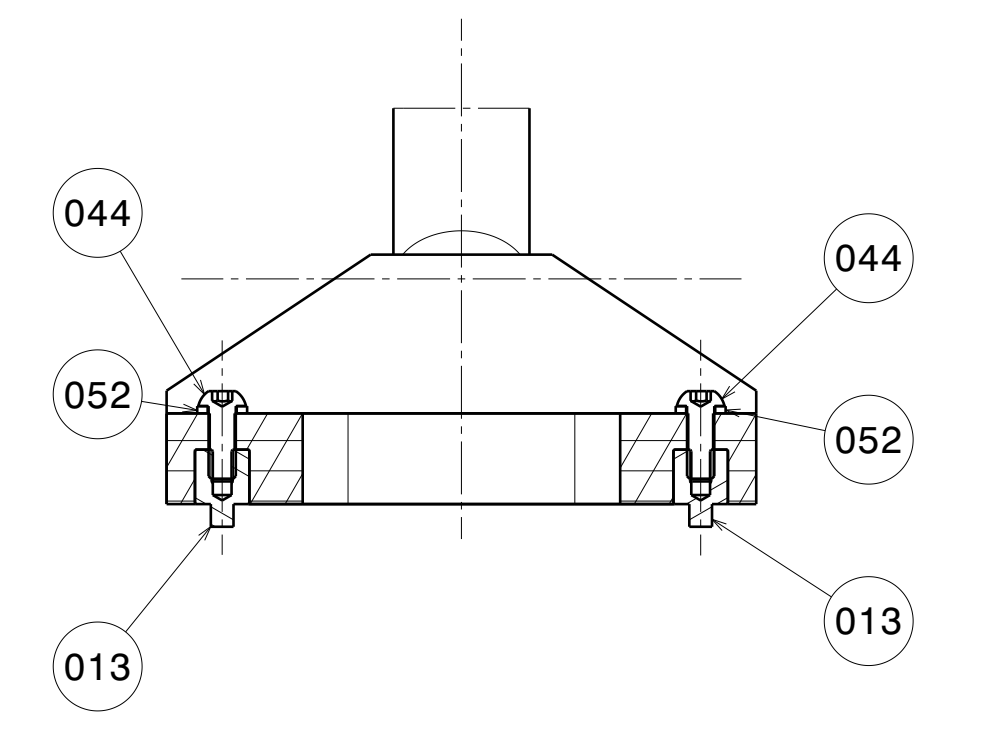

Coupe F-F  
Echelle : 3:5

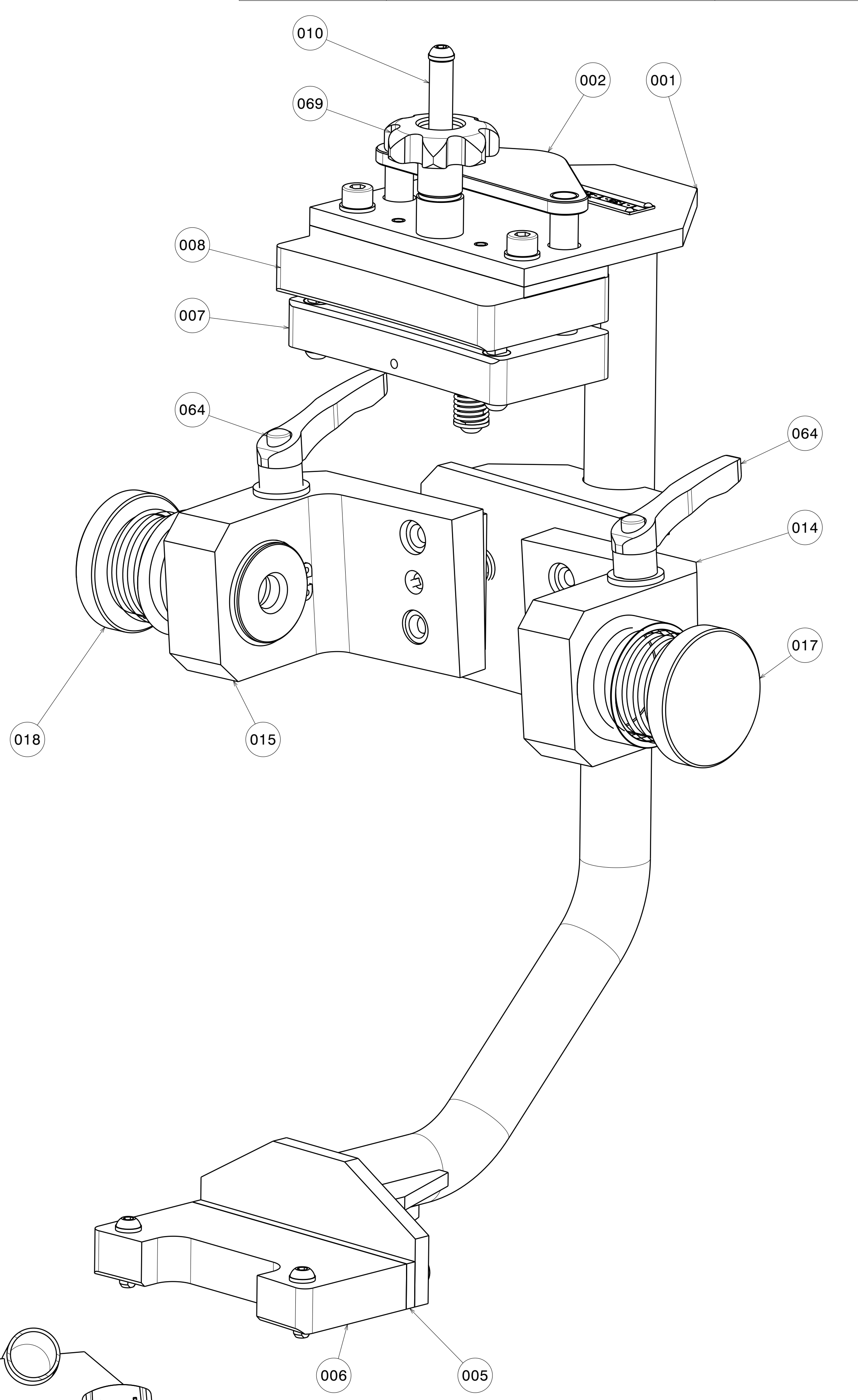
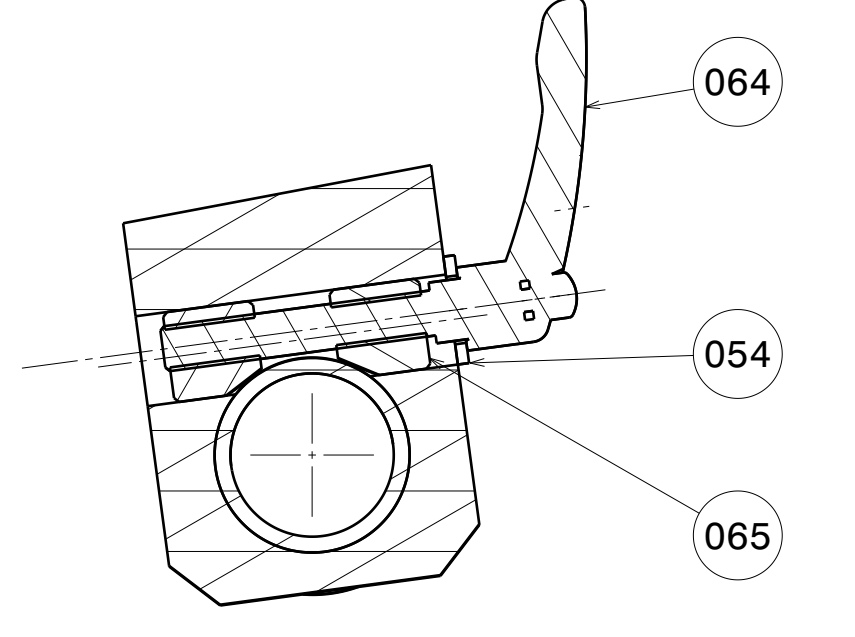

Coupe B-B  
Echelle : 3:5

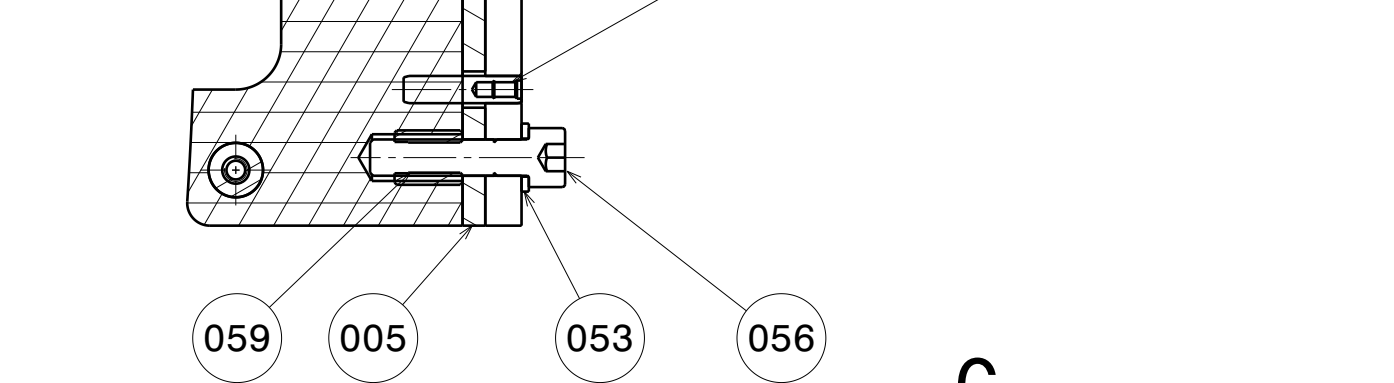

Configuration pour  
le contrôle  
MAMELON DEPART

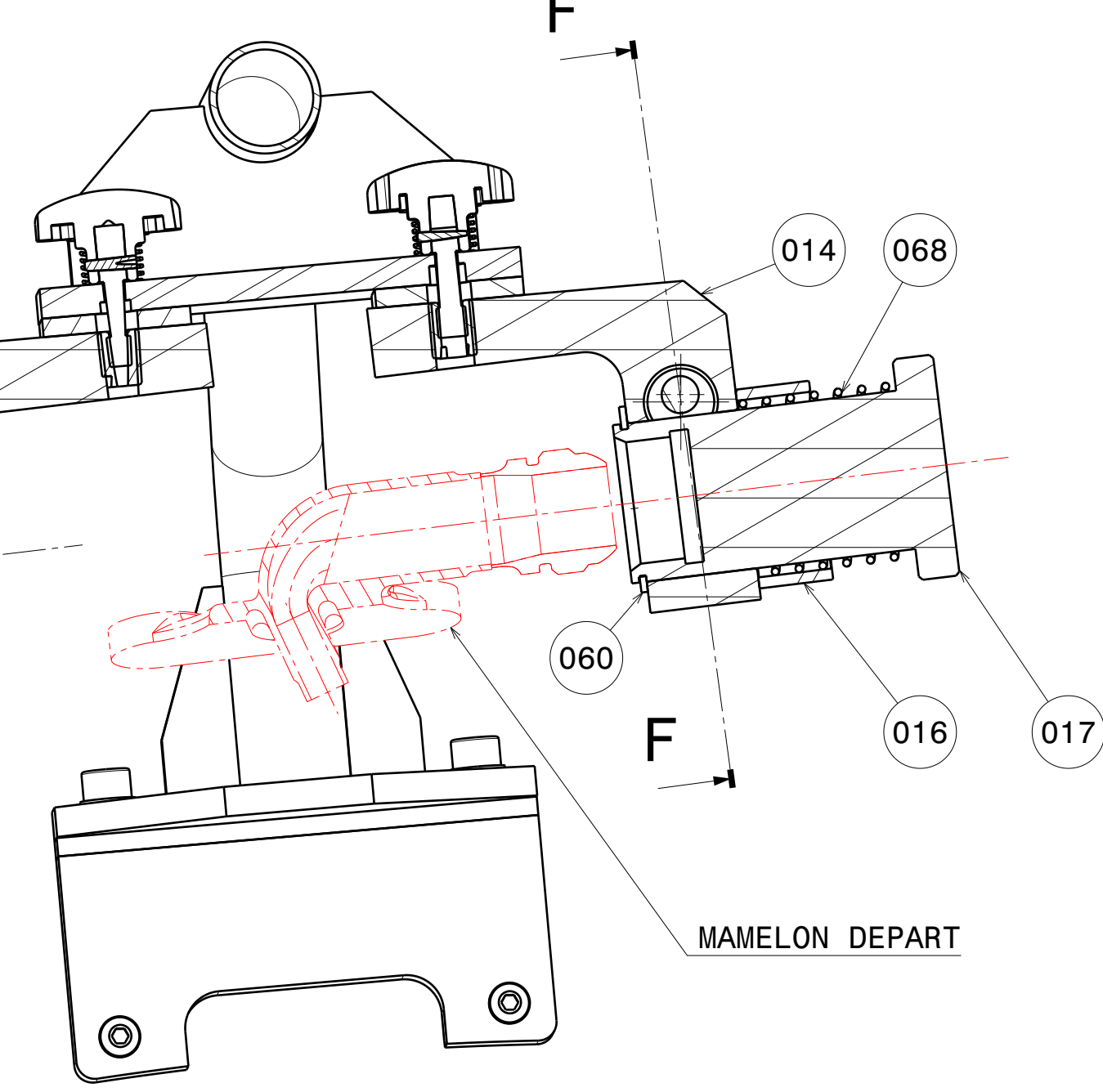

Coupe E-E  
Echelle : 3:5

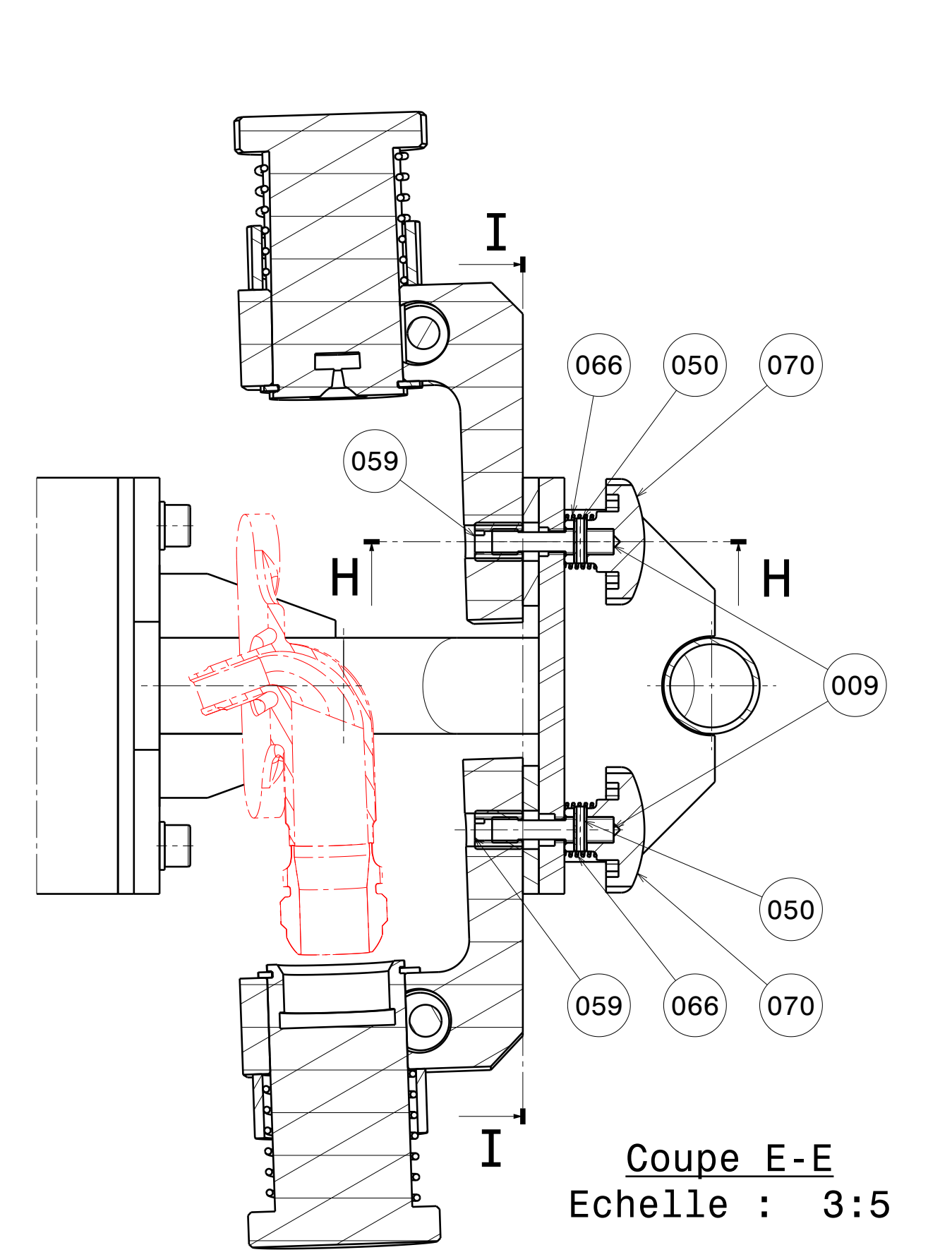

Coupe H-H  
Echelle : 3:5

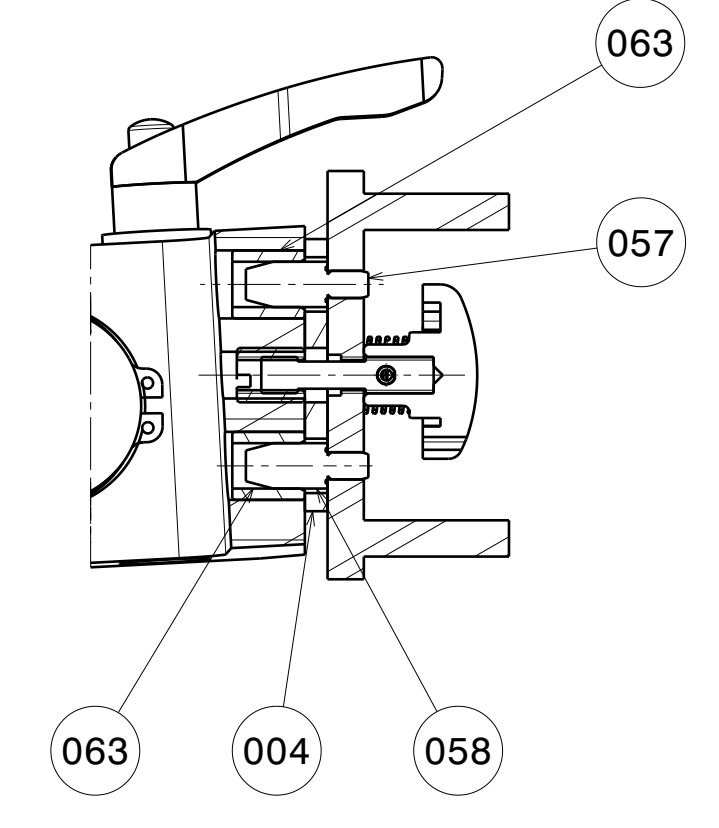

Coupe I-I  
Echelle : 3:5

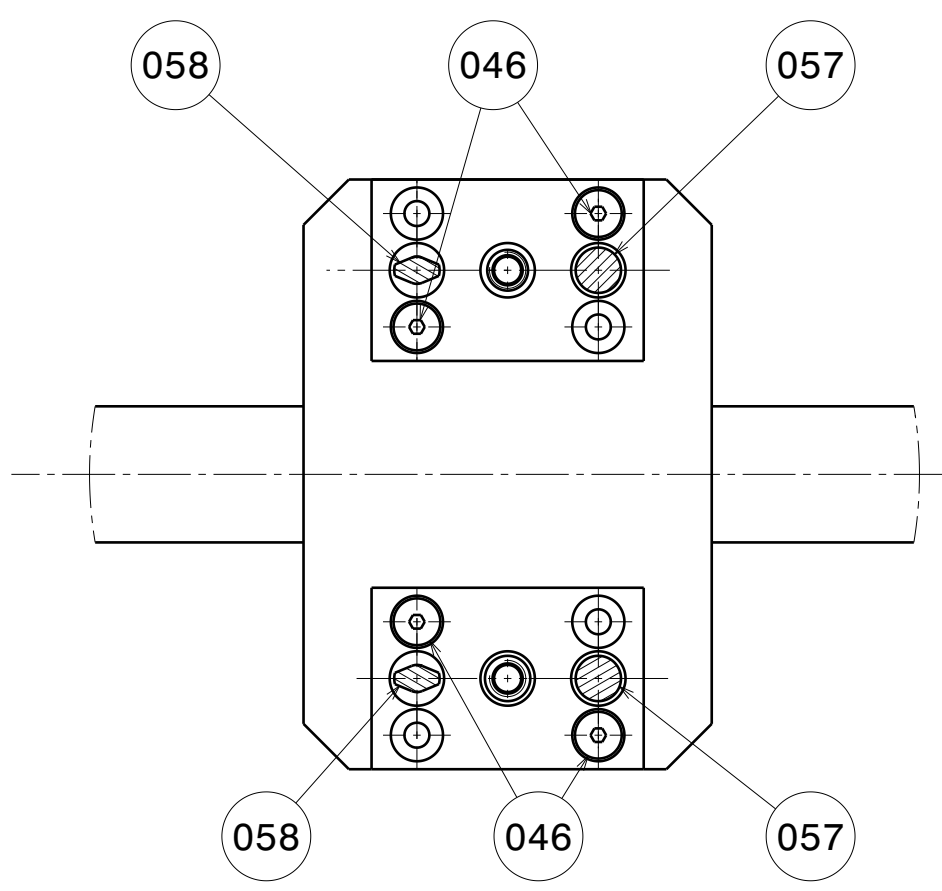

Configuration pour  
le contrôle  
MAMELON ARRIVE

Coupe C-C  
Echelle : 3:5

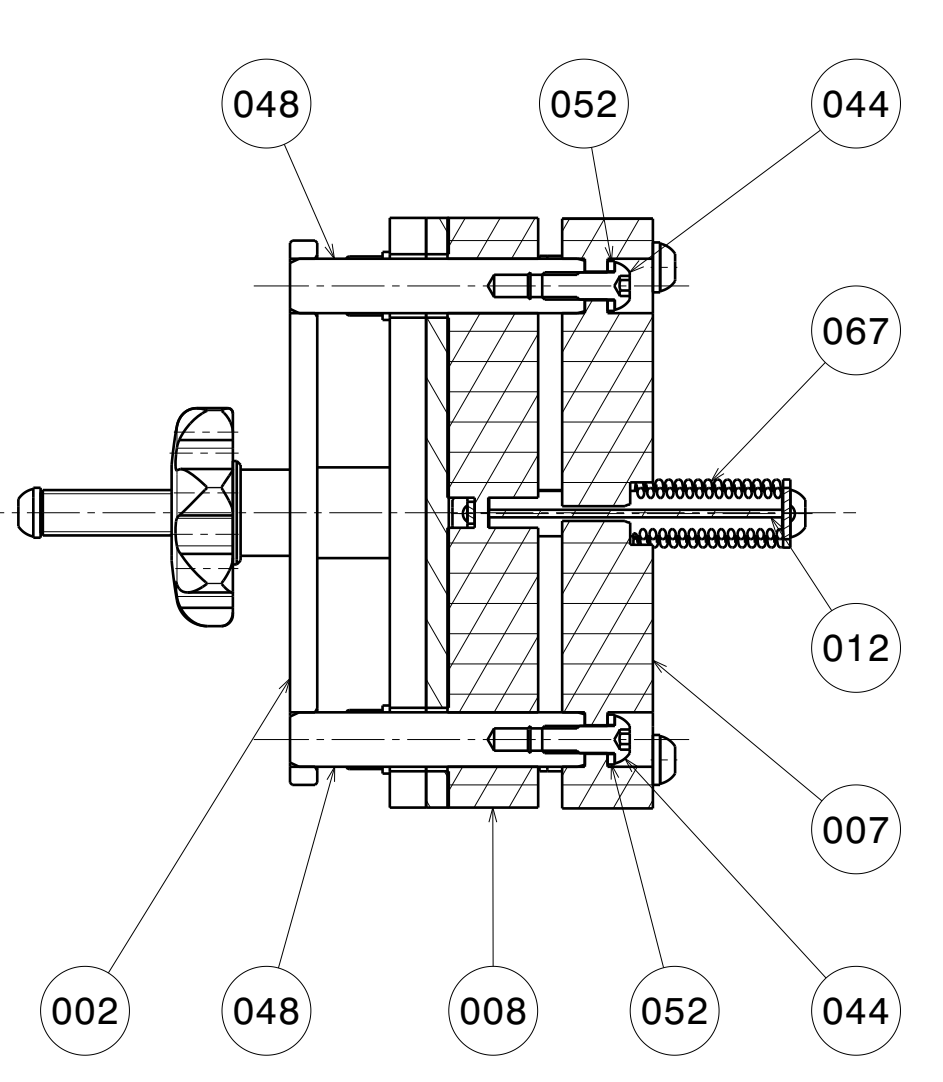

Coupe D-D  
Echelle : 3:5

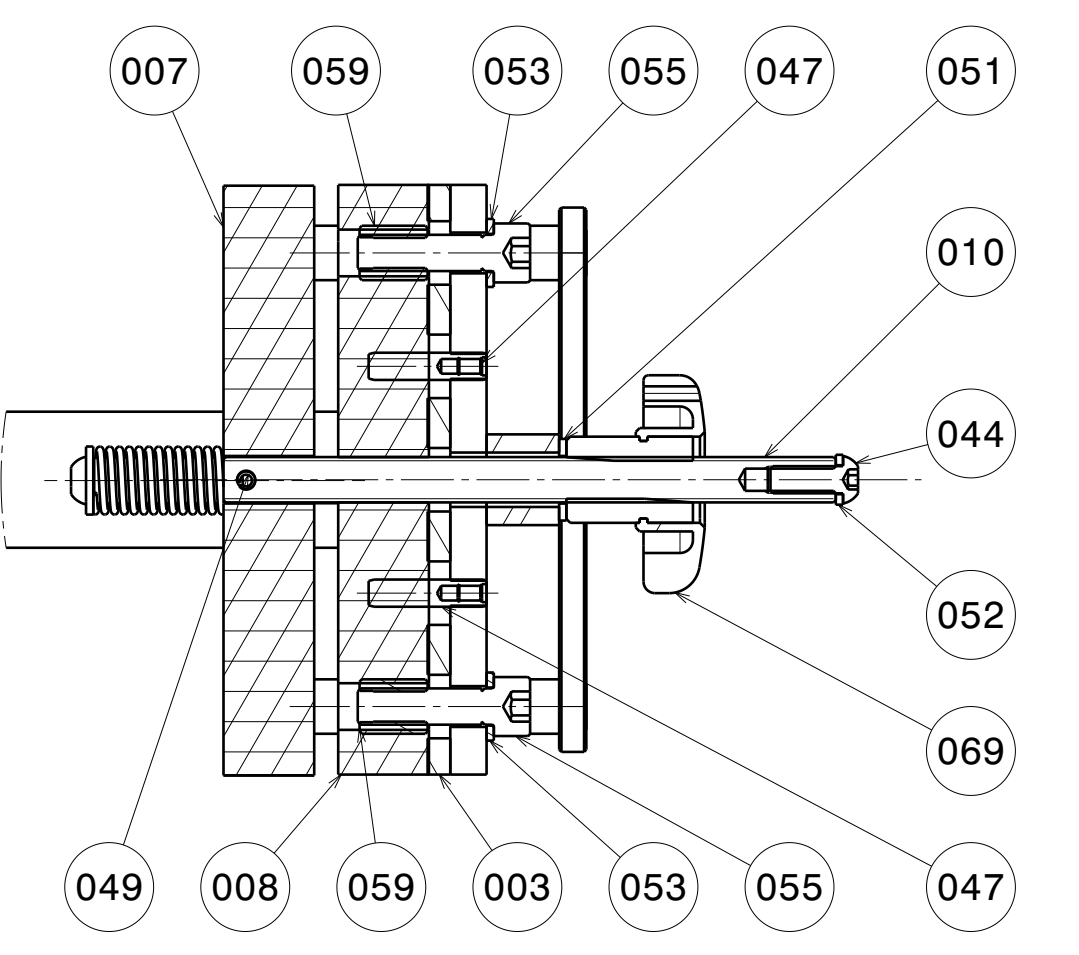

PLAQUETTE DE PROPRIETE

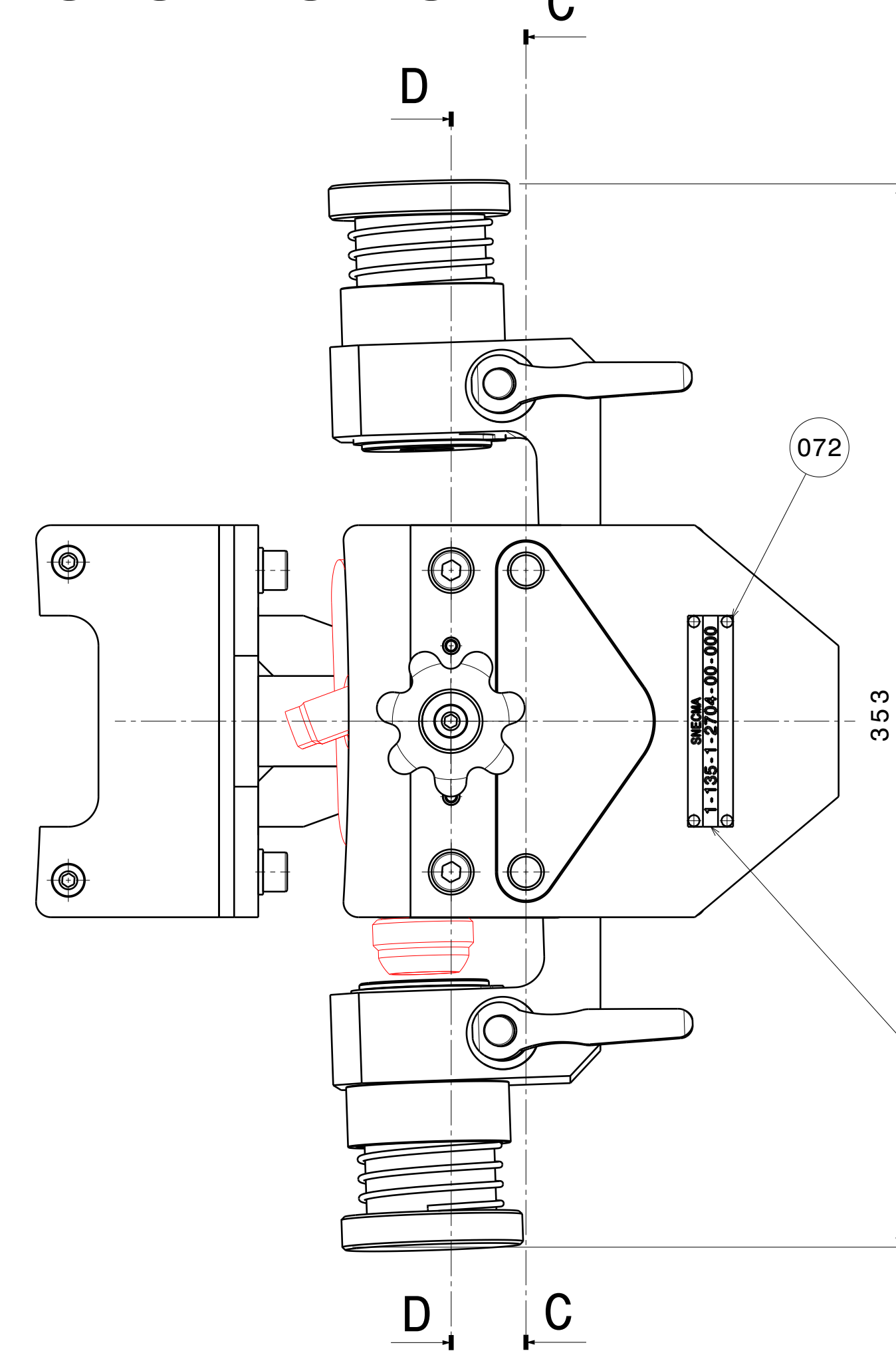

MODIF	PL	REP	QTE	DESIGNATION	MATERIES ET TRAITEMENTS
SOUS-TRAITANT				METHODES	QUALITE
Dessine par : LI SGO		Dessine par :			
Verifie par : LI SGO		Verifie par :			
UTILISE POUR :					
<b>CARTER ECHAPPEMENT</b>					
DESIGNATION : OUTILLAGE DE CONTROLE POSITION TUBES				ECHELLE : 3/5	
ETUDE OUTILLAGES					
No: 1-135-1-2704-00-000				PL : 2/9	