

INDICE	MODIFICATION	NOM ET DATE

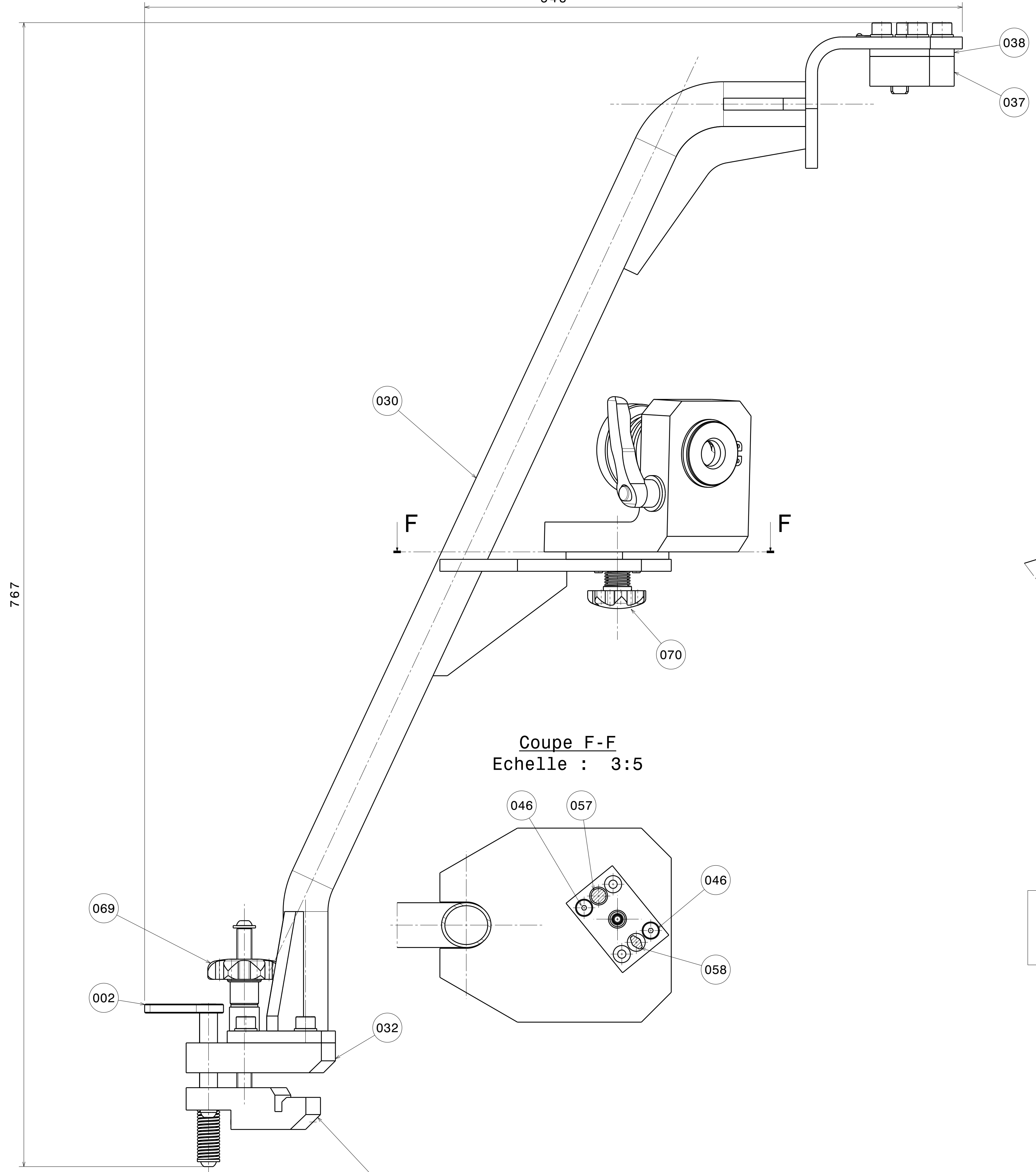

Coupe E-E  
Echelle : 3:5

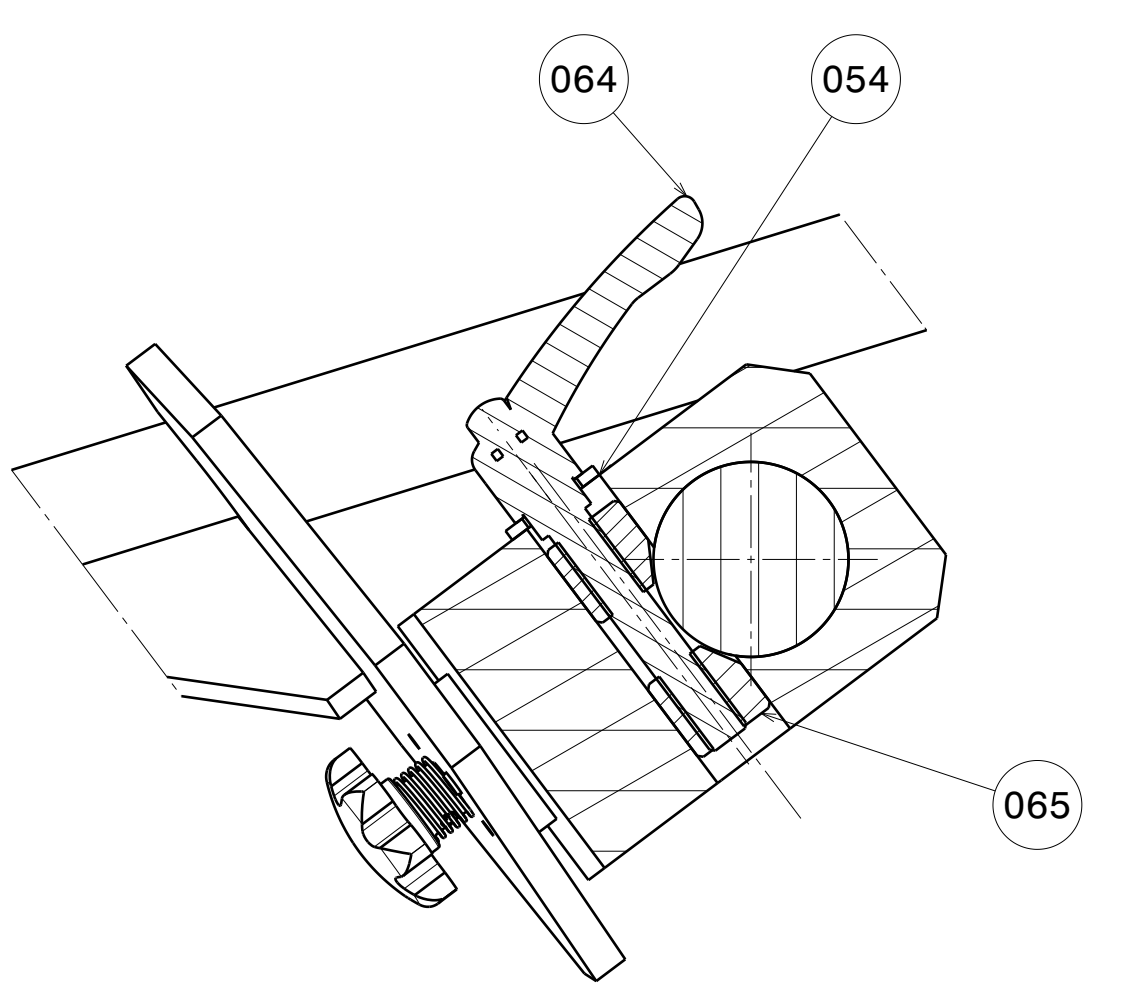

Coupe F-F  
Echelle : 3:5

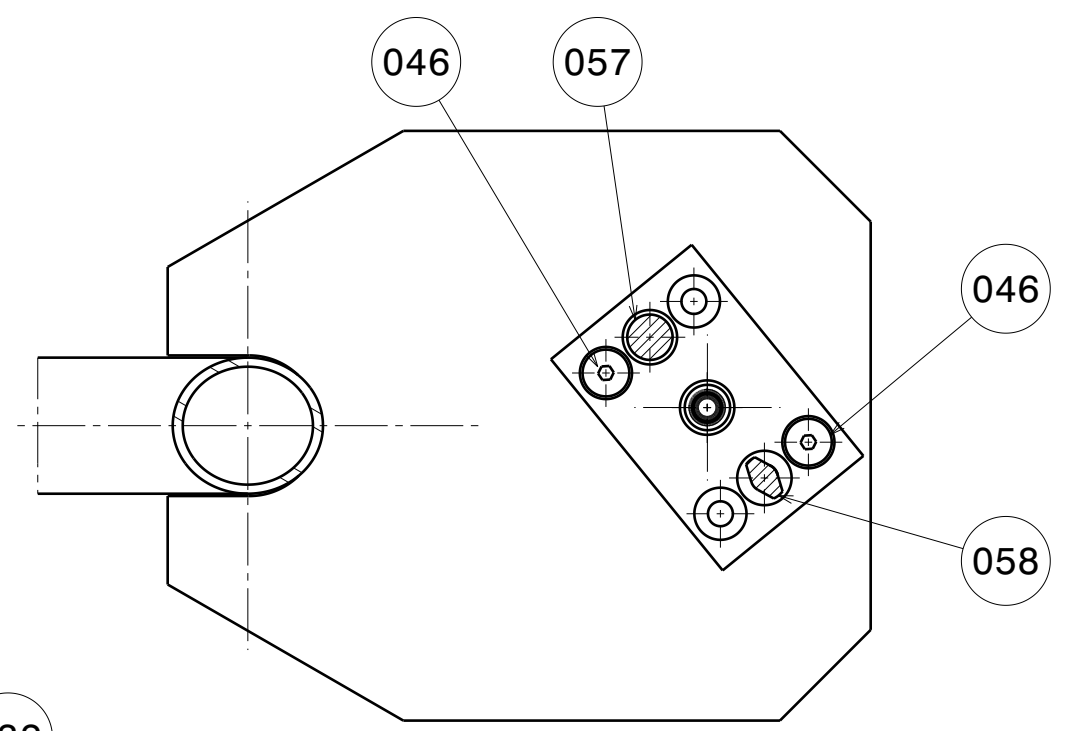

Configuration pour  
le contrôle  
TUBE ARRIVE HUILE

Coupe D-D  
Echelle : 3:5

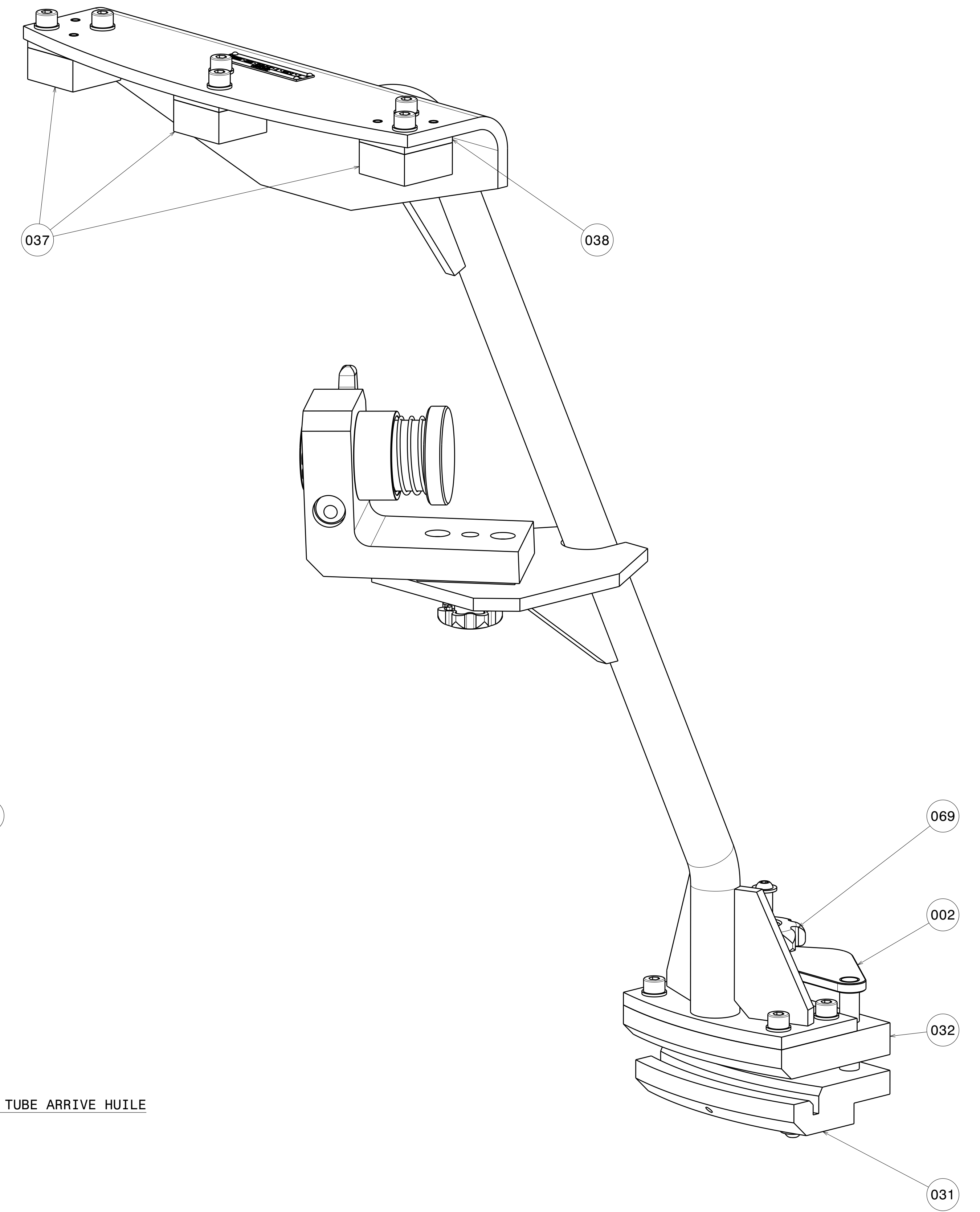
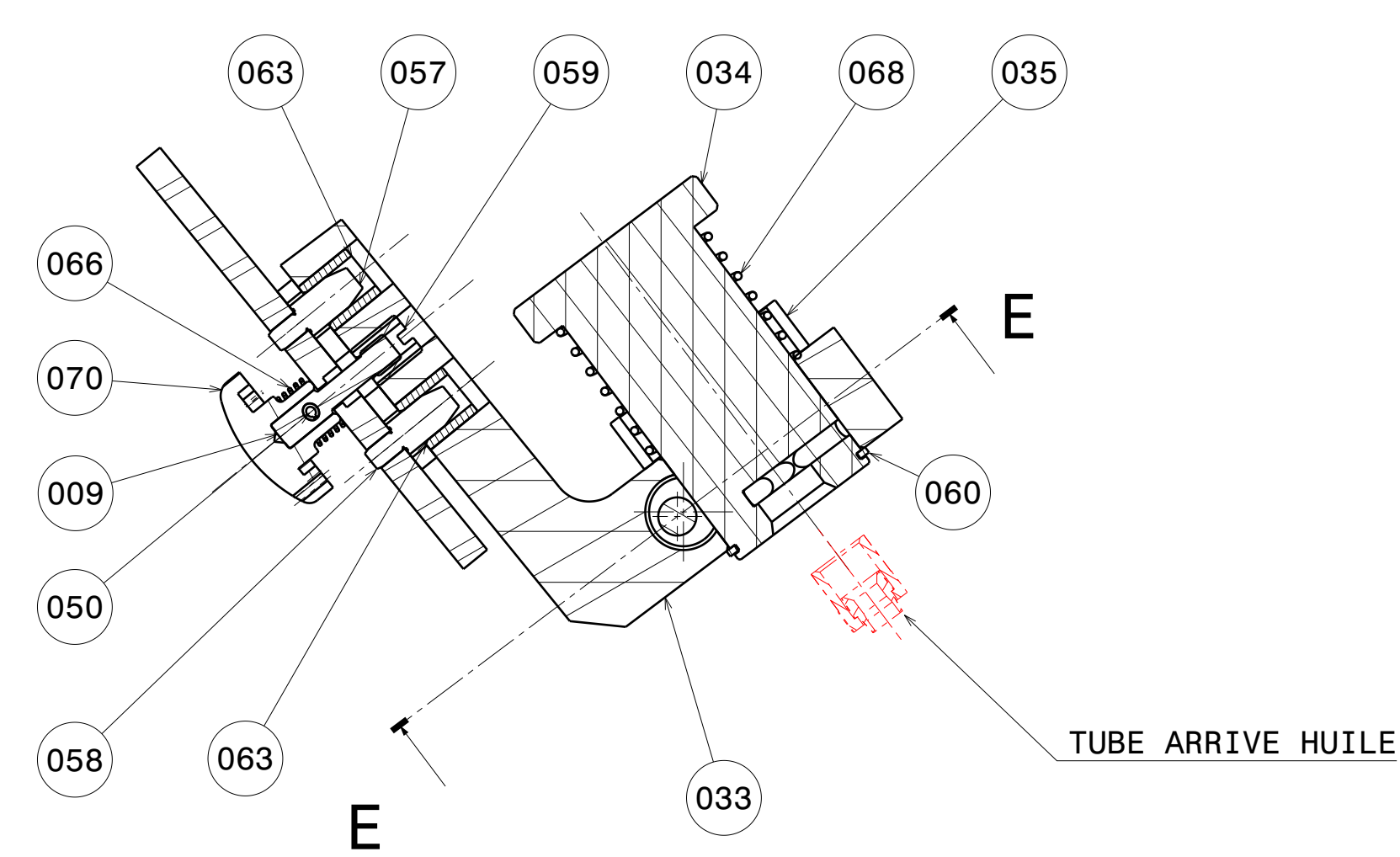

Coupe B-B  
Echelle : 3:5

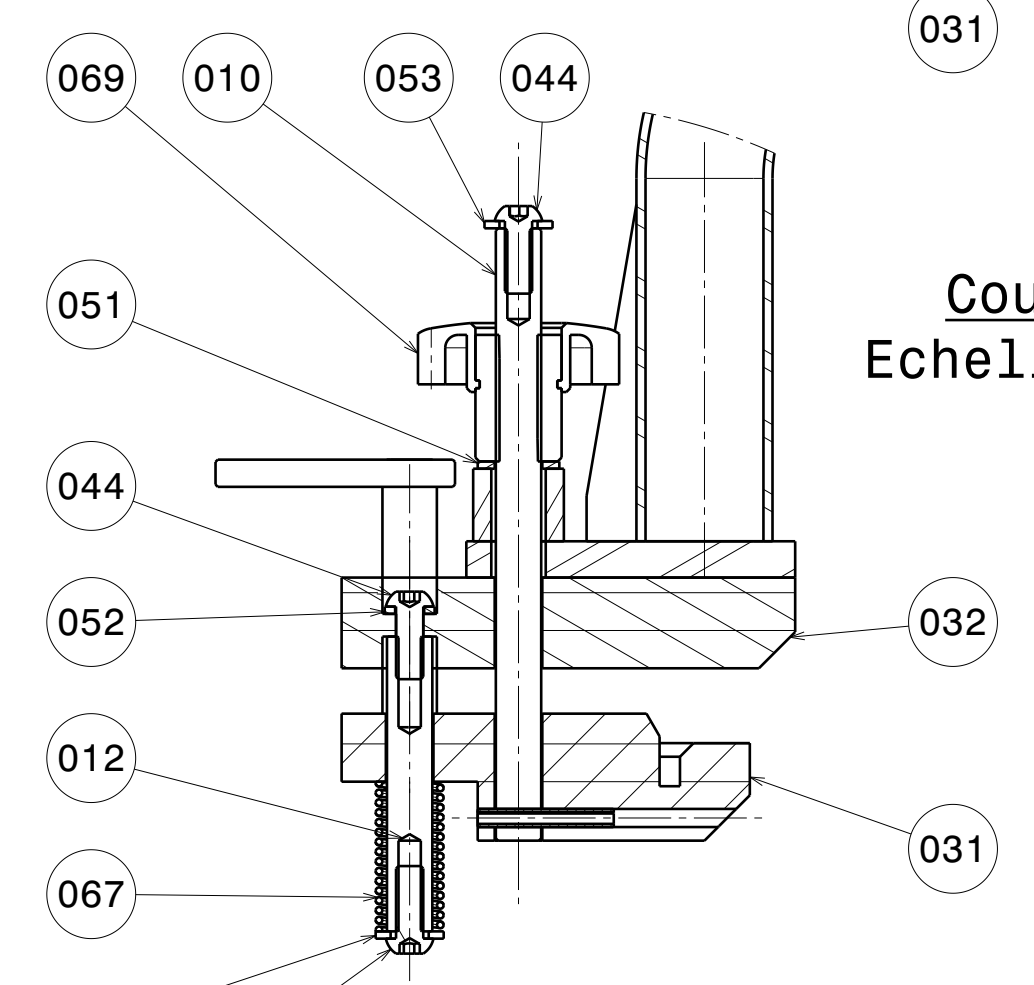

PLAQUETTE DE PROPRIETE

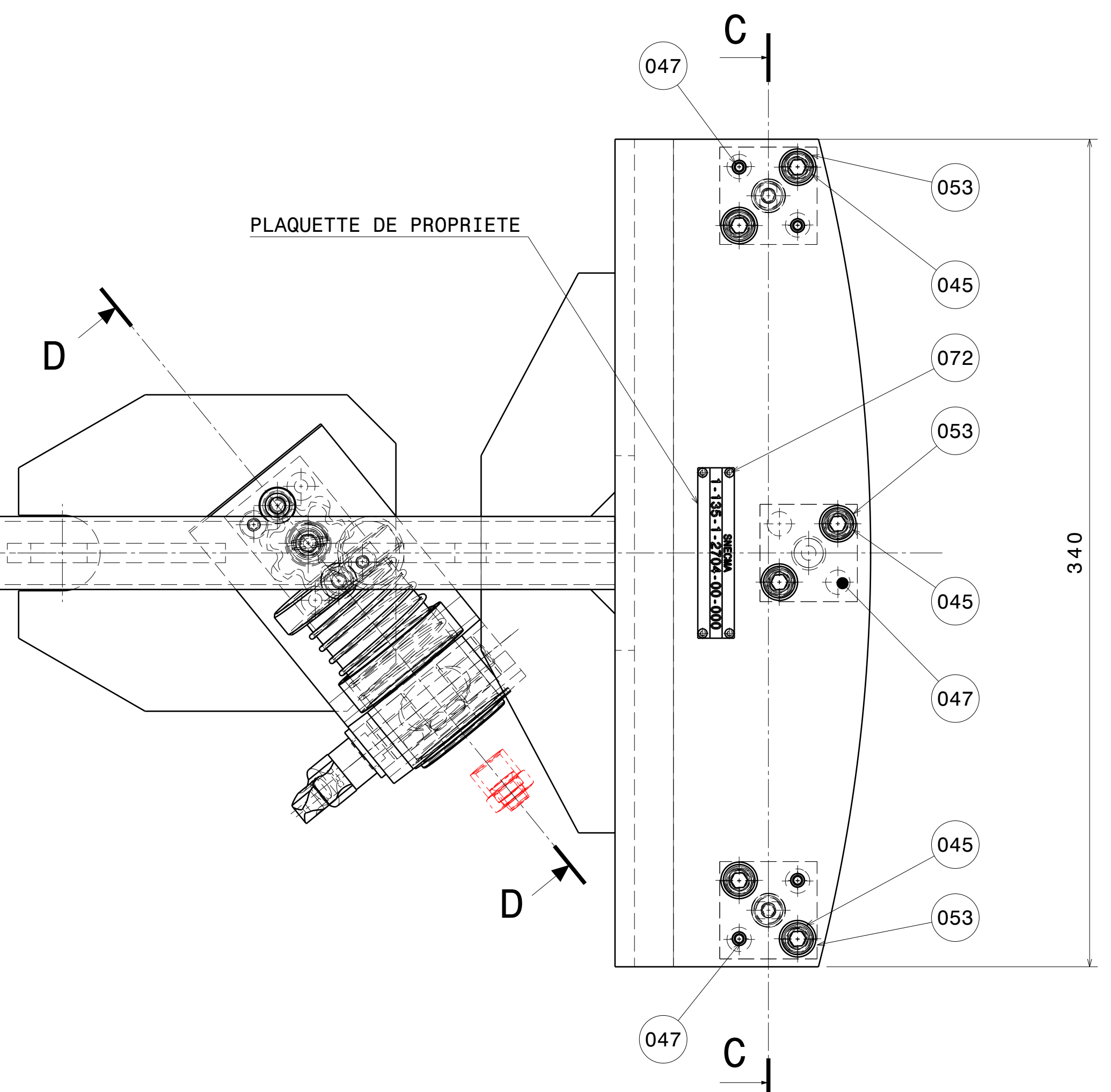

Coupe A-A  
Echelle : 3:5

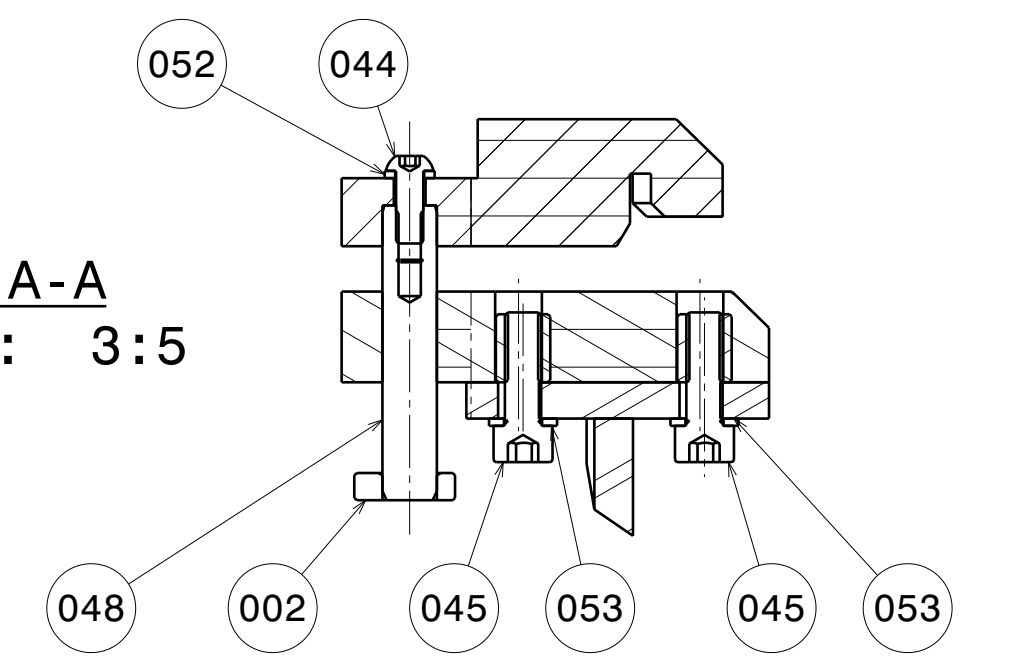

Coupe C-C  
Echelle : 3:5

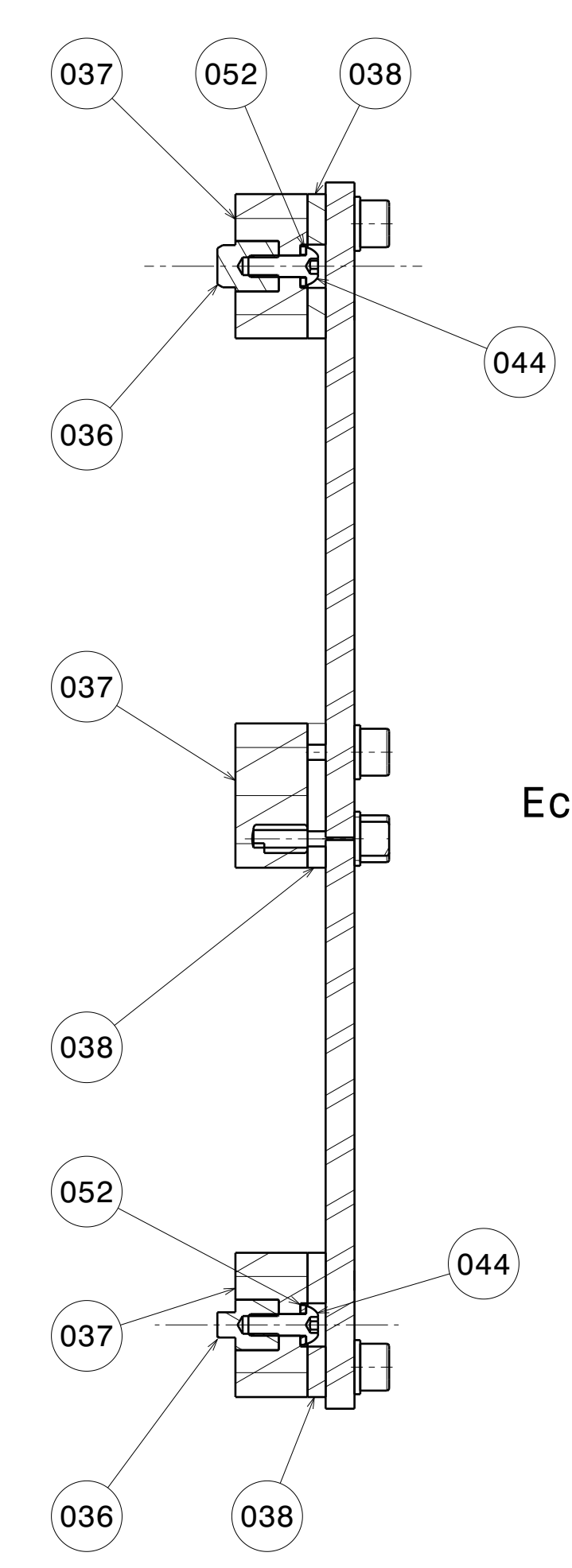

Configuration pour  
le contrôle  
TUBE RETOUR

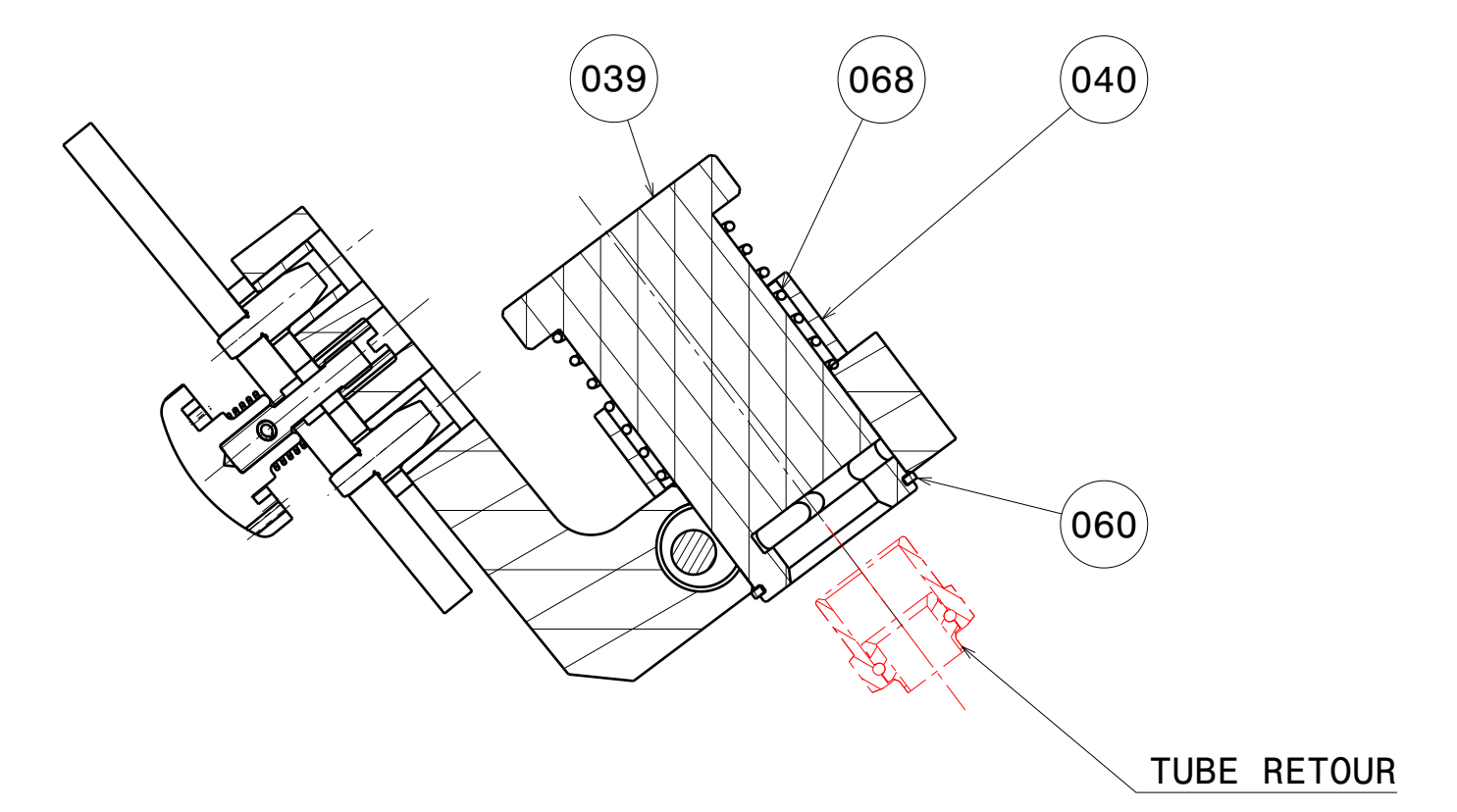

MODIF	PL	REP	QTE	DESIGNATION	MATIERES ET TRAITEMENTS

UTILISE POUR :		ECHELLE 3/5
DESIGNATION : CARTER ECHAPPEMENT OUTILLAGE DE CONTROLE POSITION TUBES		
ETUDE OUTILLAGES		PL
No: 1-135-1-2704-00-000		3/9